

16-PAGE BONUS! SPECIAL FOCUS ON AUDIO

Popular Electronics®

WORLD'S LARGEST-SELLING ELECTRONICS MAGAZINE SEPTEMBER 1977/\$1.25

HOW TO CUSTOM DESIGN CASES FOR PROJECTS

UPGRADE YOUR OLD STEREO FM TUNER

An easy-to-add phase-locked-loop IC does the trick

FIELD REPORT:

CALIFORNIA HOBBYIST COMPUTER SHOW

TRANSFORMERLESS CIRCUIT DOUBLES DC VOLTS

TEST REPORTS: Akai GX-270DSS 4-Channel Tape Recorder
Speakerlab Model 7 Speaker System Kit
General Electric AM/SSB CB Mobile Transceiver
Aries "System 300" Electronic Music Synthesizer Kit

**BUILD A 1/2-OCTAVE "REAL TIME"
AUDIO
ANALYZER**



Popular Electronics

Introducing the mobile that can move you out of the world of the ordinary and into the world of the serious CB'er. The Cobra 138XLR Single Sideband. Sidebanding puts you in your own private world. A world where there's less congestion. More privacy. More time to talk.



It's all possible because instead of 40 channels you get your choice of 120 channels. Both AM and SSB. And instead of 4 watts of legal power you get 12 watts of legal power. So you get almost double the range of AM.

With the 138XLR Single Sideband there's less background noise and less interference. So there's cleaner, clearer reception. Because like all Cobras, the 138XLR SSB is engineered to punch through loud and clear. Even in crowded metropolitan areas.

And like all Cobras it comes equipped with such standard features as an easy-to-read LED channel indicator. Switchable noise blanking and limiting. An RF/signal strength meter. And Cobra's exclusive DynaMike gain control.

You'll find the 138XLR SSB wherever Cobras are sold. Which is almost everywhere. Because Cobra's got a nationwide network of dealers and Authorized Service Centers offering sales, installation, service and advice. So come on in. And move on up.



Punches through loud and clear.

Cobra Communications Products
DYNASCAN CORPORATION
 6460 W. Cortland St., Chicago, Illinois 60635

Write for color brochure
 EXPORTERS: Empire • Plainville, N.Y. • CANADA: Atlas Electronics • Toronto

CIRCLE NO. 12 ON FREE INFORMATION CARD

UPWARD MOBILITY.



Burglar Alarm Breakthrough

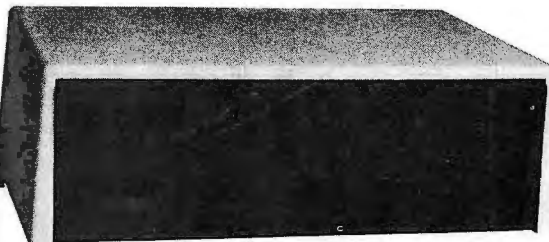

A new computerized burglar alarm requires no installation and protects your home or business like a thousand dollar professional system.

The Midex security computer looks like a handsome stereo system component and measures only 4" x 10½" x 7".

It's a security system computer. You can now protect everything—windows, doors, walls, ceilings and floors with a near fail-safe system so advanced that it doesn't require installation.

The Midex 55 is a new motion-sensing computer. Switch it on and you place a harmless invisible energy beam through more than 5,000 cubic feet in your home. Whenever this beam detects motion it sends a signal to the computer which interprets the cause of the motion and triggers an extremely loud alarm.

The system's alarm is so loud that it can cause pain—loud enough to drive an intruder out of your home before anything is stolen or destroyed and loud enough to alert neighbors to call the police.



The powerful optional blast horns can also be placed outside your home or office to warn your neighbors.

Unlike the complex and expensive commercial alarms that require sensors wired into every door or window, the Midex requires no sensors nor any other additional equipment other than your stereo speakers or an optional pair of blast horns. Its beam actually penetrates walls to set up an electronic barrier against intrusion.

NO MORE FALSE ALARMS

The Midex is not triggered by noise or sound, temperature or humidity—just motion, and since a computer interprets the nature of the motion, the chances of a false alarm are very remote.

An experienced burglar can disarm an expensive security system or break into a home or office through a wall. Using a Midex system there is no way a burglar can penetrate the protection beam without triggering the loud alarm. Even if the burglar cuts off your power, the four-hour rechargeable battery pack will keep your unit triggered, ready to sense motion and sound an alarm.

DEFENSE AGAINST PEEPING TOMS

By pointing your unit towards the outdoors from your bedroom and installing an outside speaker, light, or alarm, your unit can sense a peeping tom, and frighten him off. Pets are no problem for the Midex. Simply put them in one section of the house and concentrate the beam in another.

When the Midex senses an intruder, it remains silent for 20 seconds. It then sounds the alarm until the burglar leaves. One minute after the burglar leaves, the alarm shuts off and resets, once again ready to do its job. This

shut-off feature, not found on many expensive systems, means that your alarm won't go wailing all night long while you're away. When your neighbors hear it, they'll know positively that there's trouble.

PROFESSIONAL SYSTEM

Midex is portable so it can be placed anywhere in your home. You simply connect it to your stereo speakers or attach the two optional blast horns.

Operating the Midex is as easy as its installation. To arm the unit, you remove a specially coded key. You now have 30 seconds to leave your premises. When you return, you enter and insert your key to disarm the unit. You have 20 seconds to do that. Each key is registered with Midex and that number is kept in their vault should you ever need a duplicate. Three keys are supplied with each unit.

As an extra security measure, you can leave your unit on at night and place an optional panic button by your bed. But with all its optional features, the Midex system is complete, designed to protect you, your home and property just as it arrives in its well-protected carton.

The Midex 55 system is the latest electronic breakthrough by the Midex Corporation—a company that specializes in sophisticated professional security systems for banks and high security areas. JS&A first became acquainted with Midex after we were burglarized. At the time we owned an excellent security system but the burglars went through a wall that could not have been protected by sensors. We then installed over \$5,000 worth of the Midex commercial equipment in our warehouse. When Midex announced their intentions to market their units to consumers, we immediately offered our services.

COMPARED AGAINST OTHERS

In a recent issue of *Consumers Report*, a leading consumer publication, there was a complete article written on the tests given security devices which were purchased in New York. The Midex 55 is not available in New York stores but had it been compared it would have been rated tops in space protection and protection against false alarms—two of the top criteria used to evaluate these systems. Don't be confused. There is no system under \$1,000 that provides you with the same protection as the Midex 55.

YOU JUDGE THE QUALITY

Will the Midex system ever fail? No product is perfect but judge for yourself. All components used in the Midex system are of aerospace quality and of such high reliability that they pass the military standard 883 for thermal shock and burn-in. In short, they go through the same rugged tests and controls used on components in manned space ships.

Each component is first tested at extreme tolerances and then retested after assembly. The entire system is then put under full electrical loads at 150 degrees Fahrenheit for a full week. If there is a defect, these tests will cause it to surface.

PEOPLE LIKE THE SYSTEM

Wally Schirra, a former astronaut and scientist, says this about the Midex 55, "I know of no system that is as easy to use and provides such solid protection to the home owner as the Midex. I would strongly recommend it to anyone. I am more than pleased with my unit."

Many more people can attest to the quality of this system but the true test is how it performs in your home or office. That is why we provide a one month trial period. We give you the opportunity to personally see how fail-safe and easy the Midex system is to operate and how thoroughly it protects you and your loved ones.

Use the Midex for protection while you sleep, to protect your home while you're away or on vacation. Then after 30 days, if you're not convinced that the Midex is nearly fail-safe, easy to use, and can provide you with a security system that you can trust, return your unit and we'll be happy to send you a prompt and courteous refund. There is absolutely no obligation. JS&A has been serving the consumer for over a decade—further assurance that your investment is well protected.

To order your system, simply send your check in the amount of \$199.95 (Illinois residents add 5% sales tax) to the address shown below. Credit card buyers may call our toll-free number below. There are no postage and handling charges. By return mail you will receive your system complete with all connections, easy to understand instructions and one year limited warranty. If you do not have stereo speakers, you may order the optional blast horns at \$39.95 each and we recommend the purchase of two.

With the Midex 55, JS&A brings you: 1) A system built with such high quality that it complies with the same strict government standards used in the space program, 2) A system so advanced that it uses a computer to determine unauthorized entry, and 3) A way to buy the system, in complete confidence, without even being penalized for postage and handling charges if it's not exactly what you want. We couldn't provide you with a better opportunity to own a security system than right now.

Space-age technology has produced the ultimate personal security system. Order your Midex 55 security computer at no obligation, today.

JS&A NATIONAL SALES GROUP

Dept. PE One JS&A Plaza
Northbrook, Ill. 60062 (312) 564-9000

CALL TOLL-FREE... 800 323-6400
In Illinois call... (312) 498-6900

©JS&A Group, Inc., 1977

NOW, SCANNING OVER 6000 FREQUENCIES IS AS EASY AS USING A PUSHBUTTON PHONE.



Introducing the incredible, new Bearcat 210.

The exciting, new Scanner Radio with the space-age, computer control center that brings in every available public service frequency with pushbutton ease.

Bearcat's new 210 is as easy to program as a pushbutton phone. You can select any of the public service bands (all the available local frequencies) simply by pushing buttons.

Simply punch in the frequency numbers on the computer control center keyboard. Hit the Enter button. And you're programmed.

A large, flashing, digital readout panel shows you each frequency you've selected.

The Bearcat 210 patented search capacity lets you explore the endless world of every available public frequency out there, too.

Best of all, you're no longer limited to a given band or set of frequencies. The new Bearcat 210 is synthesized. Space-age circuitry lets you forget crystals forever.

Let's look at some Bearcat 210 features. And facts.

5 BAND COVERAGE—Includes Low, High, UHF and UHF "T" public service bands, the 2-meter amateur (Ham) band, plus other UHF frequencies.

SCANS 20 CHANNELS PER SECOND—In half a second, the Bearcat 210 scans all 10 channels.

CRYSTAL-LESS—Space-age circuitry with 5 custom designed chips. You never have to buy a crystal.

TRACK-TUNING—Patented track tuning provides full band coverage on every band.

AUTOMATIC LOCK-OUT—Locks out channels and "skips" frequencies not of current interest.

AC/DC—Mobile mounting bracket included.

SELECTIVE SCAN DELAY—Adds a two-second delay to prevent missing transmissions when "calls" and "answers" are on the same frequency.

AUTOMATIC SEARCH—New, patented feature searches out any active local public service frequency automatically. For more police, fire, marine, emergency calls. And much more.

THE NEW BEARCAT 210

THE MOST EXCITING THING THAT'S HAPPENED
TO SCANNING SINCE SCANNERS.

Electra Company
300 East County Line Road, South, Cumberland, Indiana 46229
Copyright 1977 Masco Corporation of Indiana

Popular Electronics®

WORLD'S LARGEST-SELLING ELECTRONICS MAGAZINE

FEATURE ARTICLES

PROS AND CONS OF MULTI-WAY SPEAKER SYSTEMS	Julian Hirsch	22
FIRST WEST COAST COMPUTER FAIRE	Tom Munnecke	74
HOW TO CUSTOM DESIGN PLASTIC CASES FOR PROJECTS	John Huff	81
ENGLISH-LANGUAGE SHORTWAVE BROADCASTS FOR SEPT. & OCT.	Richard E. Wood	114

CONSTRUCTION ARTICLES

½-OCTAVE REAL TIME AUDIO ANALYZER, PART I	Bob Jones & Richard Marsh	47
<i>Displays system output to permit accurate matching to room acoustics.</i>		
BUILD A TRANSFORMERLESS DC-TO-DC VOLTAGE DOUBLER	Marlowe J. Buchanan	55
BUILD "CABONGA" PART 2	James Barbarello	76

SPECIAL FOCUS: AUDIO

THE BASICS OF BUYING HI-FI COMPONENTS		57
DYNAMIC NOISE REDUCTION SYSTEMS AND EXPANDERS	William S. Gordon	60
MATCHING TAPES TO RECORDERS	Len Feldman	63
IC MULTIPLEX DECODER IMPROVES STEREO FM PERFORMANCE	Martin Meyer	67
QUIZ OF AUDIO BASICS	Robert P. Balin	71

COLUMNS

STEREO SCENE	Ralph Hodges	14
<i>Records and the Vertical Angle.</i>		
SOLID STATE	Lou Garner	85
<i>IC Audio Preamplifiers.</i>		
EXPERIMENTER'S CORNER	Forrest M. Mims	94
<i>Laser Diodes.</i>		
HOBBY SCENE Q&A	John McVeigh	96
CB SCENE	Ivan Berger	103
<i>Better Emergency Services Are NEAR.</i>		
COMPUTER BITS	Hal Chamberlin	110
<i>Update on Microprocessor Developments.</i>		
DX LISTENING	Glen Hauser	112
<i>Publications.</i>		

JULIAN HIRSCH AUDIO REPORTS

AKAI MODEL GX-270D-SS FOUR-CHANNEL TAPE RECORDER	32
SPEAKERLAB MODEL S7 SPEAKER SYSTEM KIT	36

ELECTRONIC PRODUCT TEST REPORTS

GENERAL ELECTRIC MODEL 3-5825 AM/SSB CB TRANSCEIVER	97
ARIES SYSTEM 300 ELECTRONIC MUSIC SYNTHESIZER	98

DEPARTMENTS

EDITORIAL	Art Salsberg	4
<i>TV Electronic Games Grow Up.</i>		
LETTERS		6
OUT OF TUNE		6
<i>"Digital Capacitance Meter" (April 1977); "RC Circuit Quiz" (July 1977)</i>		
NEW PRODUCTS		8
NEW LITERATURE		11
OPERATION ASSIST		118
ELECTRONICS LIBRARY		119

POPULAR ELECTRONICS, September 1977, Volume 12, Number 3, Published monthly at One Park Avenue, New York, NY 10016. One year subscription rate for U.S. \$12.00; Possessions and Canada, \$15.00; all other countries, \$18.00 (cash orders only, payable in U.S. currency). Second Class postage paid at New York, NY and at additional mailing offices. Authorized as second class mail by the Post Office Department, Ottawa, Canada, and for payment of postage in cash.

POPULAR ELECTRONICS including ELECTRONICS WORLD, Trade Mark Registered. Indexed in the Reader's Guide to Periodical Literature.

COPYRIGHT © 1977 BY ZIFF-DAVIS PUBLISHING COMPANY. ALL RIGHTS RESERVED.

Ziff-Davis also publishes Boating, Car and Driver, Cycle, Flying, Modern Bride, Popular Photography, Skiing and Stereo Review.

Material in this publication may not be reproduced in any form without permission. Requests for permission should be directed to Jerry Schneider, Rights and Permissions, Ziff-Davis Publishing Co., One Park Ave., New York, NY 10016.

Editorial correspondence: POPULAR ELECTRONICS, 1 Park Ave., New York, NY 10016. Editorial contributions must be accompanied by return postage and will be handled with reasonable care; however, publisher assumes no responsibility for return or safety of manuscripts, art work, or models.

Forms 3579 and all subscription correspondence: POPULAR ELECTRONICS, Circulation Dept., P.O. Box 2774, Boulder, CO 80302. Please allow at least eight weeks for change of address. Include your old address, enclosing, if possible, an address label from a recent issue.

JOSEPH E. MESICS
Publisher

ARTHUR P. SALSBERG
Editorial Director

LESLIE SOLOMON
Technical Editor

JOHN R. RIGGS
Managing Editor

IVAN BERGER
Senior Editor

ALEXANDER W. BURAWA
Features Editor

EDWARD I. BUXBAUM
Art Director

JOHN McVEIGH
Associate Editor

ANDRE DUZANT
Technical Illustrator

PATRICIA GIRRIER-BROWN
Production Editor

DORIS A. MATTHEWS
Editorial Assistant

Contributing Editors
Hal Chamberlin, Lou Garner, Glenn Hauser
Julian Hirsch, Ralph Hodges, Forrest Mims
Ray Newhall, Wilfred Scherer

JOSEPH E. HALLORAN
Advertising Director

JOHN J. CORTON
Advertising Sales

LINDA BLUM
Advertising Service Manager

PEGI McENEANEY
Executive Assistant

EDGAR W. HOPPER
Publishing Director

ZIFF-DAVIS PUBLISHING COMPANY
Editorial and Executive Offices
One Park Avenue New York, New York 10016
212-725-3500

Hershel B. Sarbin, President
Philip Korsant, Executive Vice President
Furman Hebb, Executive Vice President
John R. Emery, Sr. Vice President, Finance and Treasurer
Phillip T. Heffernan, Sr. Vice President
Edward D. Muhlfeld, Sr. Vice President, Sports Division
Philip Sine, Sr. Vice President
Frank Pomerantz, Vice President, Creative Services
Arthur W. Butzow, Vice President, Production
Lawrence Sporn, Vice President, Circulation
George Morrissey, Vice President
Sydney H. Rogers, Vice President
Sidney Holtz, Vice President
Albert S. Traina, Vice President
Paul H. Chook, Vice President
Edgar W. Hopper, Vice President
Robert N. Bavier, Jr., Vice President
Charles B. Seton, Secretary

William Ziff, Chairman
W. Bradford Briggs, Vice Chairman

Midwestern Office
The Pattis Group, 4761 West Touhy Ave.,
Lincolnwood, Illinois 60466, 312 679-1100
Thomas Hockney, Michael Neri, Gerald E. Wolfe
Western Office
9025 Wilshire Boulevard, Beverly Hills, CA 90211
213-273-8050; BRadshaw 2-1161
Western Advertising Manager: Bud Dean
Japan: James Yagi
Oji Palace Aoyama; 6-25, Minami Aoyama
6 Chome, Minato-Ku, Tokyo 407-1930/6821,
582-2851

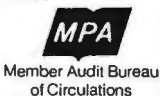

The publisher has no knowledge of any proprietary rights which will be violated by the making or using of any items disclosed in this issue.



Editorial

TV ELECTRONIC GAMES GROW UP

The sale of home TV electronic games peaked during the Christmas season of 1976, followed by a severe decline in 1977. Was the estimated 3-million video games sold in '76 just a passing fancy of the American public? Obviously not, since manufacturers are now producing with the expectation that 1977 sales will easily be twice those of 1976. And nonvideo electronic games will certainly make their mark this year, too.

Home TV games did not move as well as anticipated during the first half of '77 for a variety of reasons: (1) Christmas doesn't last all year (though the interest in games should be year-round); (2) reduced selling prices on games disheartened many retailers, who placed them on the back shelves; (3) programmable games are just around the corner. Concerning the latter, there are two companies already marketing them—Fairchild, who can't seem to keep up with consumer demands at \$170 a game plus "cartridges," and RCA, just really entering the market with a \$150 programmable model.

Dramatic decreases in prices for the older, dedicated video games are anticipated, with prognosticators saying that they will simulate the price dip exhibited by calculators and digital watches. But with the new dedicated games, such as Atari's Tank™ (with sound effects and joy-stick controls) at a suggested retail price of \$65, don't expect \$9.95 paddleball/hockey sellers to be around just yet.

The future of home video games is extraordinarily bright. And speaking of brightness, I find it amusing that one major TV receiver manufacturer, who also produces a TV electronic game, indicates that its receiver CRT warranty will be voided if electronic games are displayed on it. I've been personally assured by a top executive in the company that they have not seen a single defective CRT with burn spots caused by video electronic games—even with "duds."

The burn-spot question arose last year because some coin-operated units in arcades did display such CRT marring after a considerable period of video-game use. Users of home video games, however, do not play them sufficiently, without shutoff, to cause CRT damage.

It's projected that programmable video games will account for some 20% of unit sales in 1977, rising to 33½% by 1980. The omnipresent microprocessor will also be utilized for nonvideo electronic games. Parker Brothers (of "Monopoly" fame) will soon market a nonvideo electronic game based on the old "Battleship" game, as an example. Another toy maker, Mattel, will offer hand-held missile, auto race and football games with LED score readouts . . . Fidelity Electronics will be presenting an electronic chess game that the user plays against . . . Tryom Inc. will enable you to pit your wits against a microprocessor in the game of backgammon . . . Unisonic has a four-function calculator that can also permit one to play blackjack, even changing the deal when 38 cards are played, a la Vegas rules.

Although the programmable microprocessor games are destined to take over the electronic game market, at least in dollars, the input medium used will not necessarily be the ROM-type cartridges now prevalent. Among other possibilities that may evolve are matchbook-size tape cartridges and magnetic cards. Regarding the latter, kilobyte cards can be produced much as record discs can and, therefore, offer the potential for very low costs. The four-stripe plastic cards now available provide 1024 bytes, enough for most game programs, unless you want a Star-Trek game. Then you'll need a full blown microcomputer system.

Clearly, microprocessors are changing the face of consumer electronic products for increased efficiency and, in the case of games, to add another leisure activity to our lives.

ONLY PIONEER COULD INTRODUCE A QUARTZ PHASE LOCKED LOOP TURNTABLE AND CALL IT A BARGAIN.

Today, there's nothing more accurate than a quartz phase locked loop turntable.

It's the kind of turntable they use at radio stations and recording studios. Where people are more interested in getting a great sound than getting a great price.

Well, Pioneer has just introduced the same kind of quartz turntable. Except ours was designed for people who *do* care about price.

It's called the PL570.

And like the professional quartz turntables you'll find in all those radio stations and recording studios across the country, it features a direct-drive motor that's quieter than ordinary motors.

Plus an electronic strobe circuit that lets you adjust the PL570 far more accurately than conventional strobes.

And the same kind of quartz phase locked loop technology that automatically corrects the turntable speed to account for things like the weight of the record and even

the amount of stylus pressure. So your records can always sound perfect, because they're always spinning perfectly.

But where the average quartz phase locked loop turntable offers you all this accuracy for around \$800, our new PL570 does it for under \$400. Which, you'll have to agree, is quite a bargain. (And that's even before you find out that the PL570 is one of the few fully automatic quartz-lock turntables available today at *any* price.)

Of course, if you're looking for something a little less sophisticated than our PL570, there's still no need to look any further than Pioneer.

In all, we make eight high quality turntables. And while they may not all offer the same kind of features as our PL570, you can bank on at least one thing.

They all feature the same kind of value.

High Fidelity Components
PIONEER
WE BRING IT BACK ALIVE.

©1977 U.S. Pioneer Electronics, 85 Oxford Drive, Moonachie, New Jersey 07074



SAE Power



2600



2400L



2200

SAE's goal today, just as it has been for over 12 years, is the design and production of fine audio components; which offer the best value in both sonic performance and quality construction. Our line of amplifiers stand as a testament to this goal.

First, their design — all SAE amplifiers have fully complimentary circuitry. In this unique design approach, not only the output (as in conventional amplifiers), but the drive and input stages are completely complimentary. This ensures low transient and steady-state distortion, plus full stability and fast overload recovery. Combine this with our high slew rate for accurate transient response, feedback gain controls which will not degrade the input signal (2600, 2400L), and monocoque construction with its low weight and high reliability (2200, 2400L).

The result is state-of-the-art performance, but to realize this performance we must have the second part of our goal — production. In order to ensure optimum performance from these unique design concepts, SAE retains total control over the manufacture, selection, and assembly processes. We maintain 40,000 sq. ft. of production area where the latest techniques in metal and circuit board fabrication, component selection and product assembly are employed. The result of these efforts is the line of high quality amplifiers pictured here, each an outstanding value in its power range and each a true SAE component where performance and value come together — that's SAE Power!

SAE

Scientific Audio Electronics, Inc.
P.O. Box 60271 Terminal Annex, Los Angeles, CA 90060
CIRCLE NO. 57 ON FREE INFORMATION CARD



Letters

CUTTING DOWN THREE BYTES

In "Debugging Aids" (Computer Bits, May 1977), Hal Chamberlain has mistakenly assumed that to insert a breakpoint in an 8080 program, a three-byte CALL instruction must be used. This gives the impression that a breakpoint feature on an 8080 is clumsy at best. We recommend that 8080 users initiate one of the RESTART (RST) instructions to implement a breakpoint feature in their software. The RESTART instructions are essentially one-byte CALL instructions and require only one memory location within the user's program for storage. In fact, the RST instruction is very similar to the BRK instruction of the 6502 microprocessor.

One nice feature of both the RST and BRK instructions is that both cause the incremented program counter (PC) to be saved on the stack. This makes the "print registers and continue" function very easy to implement on either of the microprocessors.—*Christopher A. Titus, Blacksburg, VA.*

A QUESTION OF LEGALITY

Your May 1977 article titled "Build a Legal In-Flight Airline Receiver" was cause for inquiries from persons concerned with the requirements of the Federal Aviation Regulations (FAR) and the legality of using the receiver while on board an airliner. From the description of the receiver, it would be considered a "portable electronic device" and, therefore, comes under the requirements of FAR 91.19, titled "Portable Electronic Devices." This regulation places the responsibility for determining that the receiver will not cause interference to the aircraft navigation and communication systems with the air carriers, who should approve its operation while on board their aircraft.—*John W. Flavin, Chief Avionics Staff, Flight Standards Service, FAA, Washington, DC.*

HI-FI FEEDBACK

I commend Ralph Hodges for the honesty of his observations and opinions expressed in the June 1977 Stereo Scene. I concur with his skepticisms on the validity of the "phase coherence" technique in speaker systems. While in theory it may produce better patterns on the CRT of an oscilloscope, its improvement of the sound as interpreted by the human ear-brain combination is questionable. The human brain is a remarkable decoding device of audio signals and is able to perceive "true" sound even through the phase distorting motion of turning one's head a fraction of an inch. The phase-coherent speaker

system can be valid only for a controlled and stationary listening device. Otherwise it becomes no better than a conventional speaker system.—*Michael P. Liben, New York, N.Y.*

I found "Instruments I Have Miked" (Stereo Scene, July 1977) totally engrossing. The article delivered a tantalizing amount of tips to use in professional recording that whetted my appetite to pursue a career in professional recording engineering. I would like to see a great deal more material published on this topic.—*H. Douglas Black, Raleigh, NC.*

APPRECIATES "ELF"

I would like to express my appreciation for the best project I have ever built from the pages of POPULAR ELECTRONICS—the "Cosmac Elf" microcomputer (August 1976). Now I would like to see you publish plans for a cassette interface and other peripherals, plus appropriate programming, for the Elf. Keep up the good work.—*Louis Choiniere, Barton, VT.*

HERB BRIER

Herbert S. Brier, W9AD, ex-W9EGQ, died May 21, 1977 at age 63. Herb was crippled by rheumatoid arthritis at the age of 12 and was unable to attend school past grade 7. In spite of this, he taught himself advanced mathematics, electronics, Spanish, and Braille. For 17 years he was POPULAR ELECTRONICS' Amateur Radio editor, and for years wrote the Novice column in CQ magazine. He wrote one book on amateur radio, and co-authored the *VHF Handbook* with William Orr, W6SAI. He held an Extra Class amateur license. During World War II, he ran the Gary (Indiana) emergency radio station, for which he received a citation. In later years, he maintained industrial electronic equipment in Gary and Chesterton, Indiana, and tutored local residents in electronics and amateur radio.

Out of Tune

In "Digital Capacitance Meter" (April 1977), one end of C3, in Fig. 2, should be connected to pin 9 of IC1, not pin 13 as shown. The normally open contact of S1 should be connected to pin 13 of IC1, not pin 9 as shown. Also, at the center of Fig. 3, the 1.5-k resistor should be 1.5 ohms. The second lowest range measures capacitances from 0.01 to 0.99 μ F. When the switch is placed in this position, it automatically inserts a decimal point in the proper location and the display gives the capacitance directly in microfarads.

In "RC Circuit Quiz" (July 1977), the differentiator should be circuit H, and the integrator circuit J. The answers, as given, were reversed.

An Extraordinary Offer to introduce you to the benefits of Membership in

ELECTRONICS BOOK CLUB

take any **3** of these unique electronics books (value to \$51⁷⁵) for only **99¢** each

with a Trial Membership in the Book Club that guarantees to save you 25% to 75% on a wide selection of electronics books

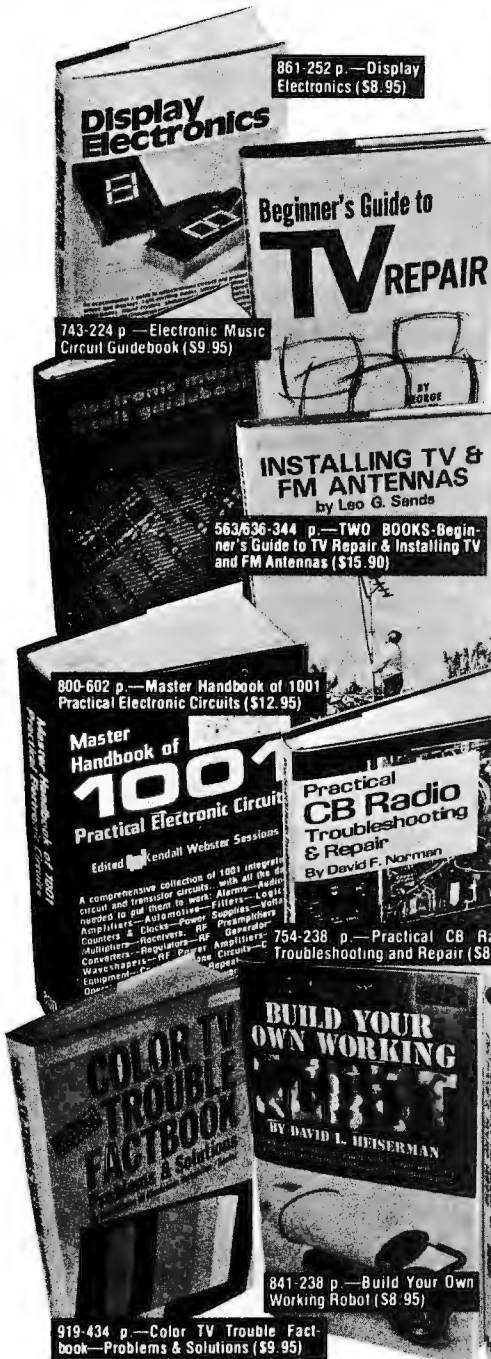

May we send you your choice of these 3 practical, time-and-money-saving books as part of an unusual offer of a Trial Membership in Electronics Book Club?

Here are quality hardbound volumes, each especially designed to help you increase your know-how, earning power, and enjoyment of electronics. Whatever your interest in electronics, you'll find Electronics Book Club offers practical, quality books that you can put to immediate use and benefit.

This extraordinary offer is intended to prove to you, through your own experience, that these very real advantages can be yours...that it is possible to keep up with the literature published in your areas of interest, and to save substantially while so doing. As part of your Trial Membership, you need purchase as few as four books during the coming 12 months. You would probably buy at least this many, anyway...without the substantial savings offered through Club Membership.

To start your Membership on these attractive terms, simply fill out and mail the coupon today. You will receive the 3 books of your choice for 10-day inspection. **YOU NEED SEND NO MONEY!** If you are not delighted, return the books within 10 days and your Trial Membership will be cancelled without cost or obligation.

Facts About Club Membership

- The 3 introductory books of your choice carry publishers' retail prices of up to \$51.75. They are yours for only 99¢ each (plus postage and handling) with your Trial Membership.
- You will receive the Club News, describing the current Selection Alternates and other offerings, every 4 weeks (13 times a year).
- If you want the Selection, do nothing; it will be sent to you automatically. If you do not wish to receive the Selection, or if you want to order one of the many Alternates offered, you simply give instructions on the reply form (and in the envelope) provided, and return it to us by the date specified. This date allows you at least 10 days in which to return the form. If, because of late mail delivery, you do not have 10 days to make a decision and so receive an unwanted Selection, you may return it at Club expense.
- Personal service for your account—no computers used!
- To complete your Trial Membership, you need buy only four additional monthly selections or alternates during the next 12 months. You may cancel your Membership any time after you purchase these four books.
- All books—including the Introductory Offer—are fully returnable after 10 days if you're not completely satisfied.
- All books are offered at low Member prices, plus a small postage and handling charge. Prepaid orders shipped postpaid.
- Continuing Bonus: If you continue after this Trial Membership, you will earn a Dividend Certificate for every book you purchase. Three Certificates plus payment of the nominal sum of \$1.99, will entitle you to a valuable Book Dividend of your choice which you may choose from a list provided Members.

ELECTRONICS BOOK CLUB

P.O. Box 10
Blue Ridge Summit, Pa. 17214

Please open my Trial Membership in ELECTRONICS BOOK CLUB and send me the 3 books circled below. I understand the cost of the books I have selected is only 99¢ each, plus a small shipping charge. If not delighted, I may return the books within 10 days and owe nothing, and have my Trial Membership cancelled. I agree to purchase at least four additional books during the next 12 months, after which I may cancel my membership at any time.

101	563/636	510/628	582	743
780/790	754	785	800	841
861	905	909	913	919
			1010	

Name _____ Phone _____

Address _____

City _____

State _____ Zip _____

(This offer valid for new Members only. Foreign and Canada add 10%) PE-97



New Products

Additional information on new products covered in this section is available from the manufacturers. Either circle the item's code number on the Reader Service Card inside the back cover or write to the manufacturer at the address given.

SONY THREE-WAY SPEAKER SYSTEM

Sony's Model SU-3000 speaker system features a "carbocon" cone material that is claimed to provide reproduction that virtually mirrors the original sound. The three-way bass-reflex system is rated to be driven by 20 watts of amplifier power and to handle up to 150 watts over a frequency range of 35 to 20,000 Hz. Crossovers are at 600 and 5500 Hz, while woofer rolloff and tweeter turn-on are at a 12-dB/octave rate. The midrange driver and tweeter are fronted by radial diffusion elements which are said to smooth the frequency response and provide improved dispersion and imaging. Dual-slope level control network and adjustable midrange and tweeter controls permit adjustment to suit the listening room. Size is 34 $\frac{1}{4}$ "H x 14 $\frac{1}{4}$ "D x 13 $\frac{1}{4}$ "W (87 x 36.2 x 34.3 cm) and weight is 59 lb 9 oz (27 kg). \$300.

CIRCLE NO. 85 ON FREE INFORMATION CARD

BEARCAT PROGRAMMABLE SCANNER

Communications Electronics' new Bearcat 210 five-band programmable "super" synthesized scanning receiver needs no crystals. It gives the user push-button access to more than 16,000 different frequencies in the 32-to-50-, 146-to-174-, and 416-to-512-MHz ranges, which include frequencies on 2 me-



ters and the entire 0.75-meter amateur band. The synthesizer permits one to enter or change any 10 frequencies in seconds. The receiver scans entered frequencies at a rate of 20 channels per second. A digital input and display allows the operator to see the frequencies selected as well as those being received. Automatic search scanning and lock-out are included. Sensitivity is rated at 0.6 μ V for 12 dB SINAD on the low and high bands. \$319.95.

CIRCLE NO. 91 ON FREE INFORMATION CARD

MARANTZ STEREO RECEIVERS

Marantz has added three popularly priced AM/FM receivers to its line. Featuring dual-gate MOSFET front ends, the receivers are equipped with zone-detented tone controls for convenient variation of bass, midrange, and treble frequencies. Other features include Dolby FM de-emphasis (25- μ s), full complementary symmetry direct-coupled amplifier section, phase-locked-loop multiplex demodulator, and quadradial-ready jack so



that a 4-channel decoder can be connected should a standardized 4-channel FM broadcast system be approved by the FCC. The three new models are 2226 (26 watts), 2238 (38 watts), and 2252 (52 watts), all into 8-ohm loads. The 2226 is rated at no more than 0.2% THD with an 8-ohm load; the other two models, 0.1%. All models include separate FM-tuning and signal-strength meters.

CIRCLE NO. 92 ON FREE INFORMATION CARD

McKAY DYMEK COMMUNICATIONS RECEIVER

McKay Dymek has introduced an all-wave, fully synthesized communications receiver covering the frequency range of 50 kHz to 29.7 MHz. The DR-22 is equipped with switch-selectable 4- or 8-kHz bandwidth ceramic filters. Preceding the ceramic filters are crystal filters at 30 MHz and 10.7 MHz. All AM broadcast, international shortwave, ham radio contacts, and CB channels are tuned in by means of a digital phase-locked-loop tuning system. A large five-digit LED readout indicates the frequency being received, which is selected by four rotary switches and a fine-tuning control with a \pm 5-kHz tuning range. Standard features include high-impedance audio output for recording, 455-kHz i-f output jack, mute control for use with transmitters, front-panel headphone jack, internal speaker and control switch, and external speaker connections. The receiver is housed in a textured black enamel case with teak wood sides and brushed aluminum face. Measures 17.5"W x 16"D x 5.1"H (44.5 x 40.7 x 13.0 cm). \$2,900.

CIRCLE NO. 93 ON FREE INFORMATION CARD

CONTINENTAL SPECIALTIES SOCKETS

Continental Specialties has two new "Experimenter" 300 and 600 solderless breadboarding sockets, which provide 94 five-point terminals, plus two 40-point bus strips for a total of 550 solderless tie-points. The 600, priced at \$10.95, has a 6/10" center channel, making it suitable for microprocessors, clock chips, RAM's, ROM's, and other larger DIP

packages. The 300 has a 3/10" center channel that is right for smaller DIP's. Both sockets also accept transistors, LED's, resistors, capacitors, pots and virtually all types of discrete components.

CIRCLE NO. 94 ON FREE INFORMATION CARD

HEATH AUDIO OSCILLATOR

Heath's IG-1272 low-distortion oscillator is designed for a variety of audio uses. It provides a low-distortion sine-wave output over a frequency range from less than 5 Hz to 100 kHz. It offers both pushbutton and variable-frequency operation. Output is said to be flat across its entire frequency range. Attenuation accuracy is \pm 0.2 dB. Hum and noise are rated at 0.01% or less. Includes an ac rms volts meter with a dB scale and a level control, plus an interval load (600 ohms) and external load switch. It comes with cable and clip leads as a kit for \$129.95, factory assembled (SG-1272). \$190.

CIRCLE NO. 90 ON FREE INFORMATION CARD

PANASONIC MOBILE CB TRANSCEIVER

Panasonic's Model RJ-3450 is a two-piece AM 40-channel rig. The CB transceiver is separate from its controls to allow the bulkier section to be hidden away under a seat or, with an optional extender cable, in the car's trunk. The remote-control microphone contains all controls, switches, and displays



(LED), as well as the speaker. The RJ-3450 also features a built-in scanner system that can be operated either automatically or manually. It can be set to either V (vacant) or B (busy) to automatically locate an open or a busy channel. In the manual position, channels can be stepped through, up or down, one at a time. Other controls are a squelch control, noise-blanker/ani switch, and a REG/CH-9 switch. \$229.95.

CIRCLE NO. 95 ON FREE INFORMATION CARD

EDMUND SCIENTIFIC BURGLAR ALARMS

Two new security alarms are being offered by Edmund Scientific. One is a portable that can

Understanding Digital Electronics

New teach-yourself courses

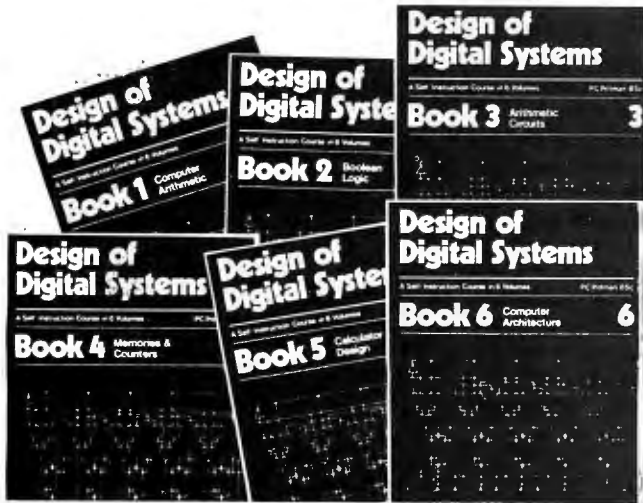

Design of Digital Systems is written for the engineer seeking to learn more about digital electronics. Its six volumes — each 11-1/2" x 8-1/4" — are packed with information, diagrams and questions designed to lead you step-by-step through number systems and Boolean algebra to memories, counters and simple arithmetic circuits, and finally to a complete understanding of the design and operation of calculators and computers.

The contents of Design of Digital Systems include:

Book 1 Octal, hexadecimal and binary number systems; conversion between number systems; representation of negative numbers; complementary systems; binary multiplication and division.

Book 2 OR and AND functions; logic gates; NOT, exclusive-OR, NAND, NOR and exclusive-NOR functions; multiple input gates; truth tables; De Morgans Laws; canonical forms; logic conventions; Karnaugh mapping; three-state and wired logic.

Book 3 Half adders and full adders; subtractors; serial and parallel adders; processors and arithmetic logic units (ALUs); multiplication and division systems.

Book 4 Flip flops; shift registers; asynchronous and synchronous counters; ring, Johnson and exclusive-OR feedback counters; random access memories (RAMs) and read only memories (ROMs).

Book 5 Structure of calculators; keyboard encoding; decoding display data; register systems; control unit; program ROM; address decoding; instruction sets; instruction decoding; control program structure.

Book 6 Central processing unit (CPU); memory organization; character representation; program storage; address modes; input/output systems; program interrupts; interrupt priorities; programming; assemblers; computers; executive programs; operating systems and time sharing.



Digital Computer Logic and Electronics is designed for the beginner. No mathematical knowledge other than simple arithmetic is assumed, though the student should have an aptitude for logical thought. It consists of four volumes — each 11-1/2" x 8-1/4" — and serves as an introduction to the subject of digital electronics. Everyone can learn from it — designer, executive, scientist, student, engineer.

Contents include: Binary, octal and decimal number systems; conversion between number systems; AND, OR, NOR and NAND gates and inverters; Boolean algebra and truth tables; De Morgans Laws; design of logic circuits using NOR gates; R-S and J-K flip flops; binary counters, shift registers and half adders.

In the years ahead the products of digital electronics technology will play an important part in your life. Calculators and digital watches are already commonplace. Tomorrow a digital display could show your automobile speed and gas consumption; you could be calling people by entering their name into a telephone which would automatically look up their number and dial it for you.

These courses were written by experts in electronics and learning systems so that you could teach yourself the theory and application of digital logic. Learning by self-instruction has the advantages of being faster and more thorough than classroom learning. You work at your own pace and must respond by answering questions on each new piece of information before proceeding.

After completing these courses you will have broadened your career prospects and increased your fundamental understanding of the rapidly changing technological world around you.

The six volumes of Design of Digital Systems cost only: **\$19⁸⁸**

And the four volumes of Digital Computer Logic and Electronics cost only: **\$14⁸⁸**

But if you buy both courses, the total cost is only: **\$29⁹⁰**

a saving of over: **\$5⁰⁰**

SEVEN-DAY MONEY-BACK GUARANTEE: If you are not satisfied with your Cambridge course, return it within 7 days for a full refund.

To order your books, complete the order form below and send it together with your check or money order to GFN Industries, Inc., 6 Commercial Street, Hicksville, N.Y. 11801.

To: GFN INDUSTRIES, INC.

6 COMMERCIAL STREET, HICKSVILLE, NY 11801

Please send me:

___ Sets of Design of Digital Systems \$19.88 _____

___ Sets of Digital Computer Logic & Electronics \$14.88 _____

___ Sets of both courses \$29.90 _____

Sales tax (N.Y. residents) _____

Shipping and handling \$2.50 per set _____

Enclosed is check/mo (payable to GFN Industries, Inc.)

Total \$ _____

Name _____

Address _____

City/State/Zip _____

Prices include overseas surface mail postage.

PE-9B

be carried anywhere, while the other is designed for permanent installation. The latter is useful for cars, trucks, RV's, boats, and industrial plant protection, while the portable unit is for office and personal security. The portable alarm uses ultrasonics to secure a "protected" area. Each alarm is programmed with its own specific two-digit "off" code. Portable alarm No. 61,119 with 9-volt battery: \$79.00. The No. 61,120 12-volt permanent alarm, with lead-in wires: \$79.00.

CIRCLE NO. 96 ON FREE INFORMATION CARD

MXR NOISE-REDUCTION ACCESSORY

The MXR Comander is a noise-reduction device that is said to be capable of doubling the dynamic range of most open-reel and cassette tape decks. In operation, it compresses the dynamic range of signals being recorded and then expands them upon playback. The compression/expansion process is claimed to reduce noise and allow quiet passages to be heard while, at the same time, allowing musical peaks to be reproduced without distortion. The Comander is designed to process all frequencies at all levels in a similar manner, thereby eliminating the need for critical level adjustments. A switch is provided to bypass the Comander's circuitry, and a LEVEL MATCH control allows for compensation of level differences between the inputs and outputs of a tape deck. The system is designed for use on

three-head decks. Dynamic range is specified as being 100 dB and frequency response at 30 to 20,000 Hz \pm 1 dB at 0 dBV.

CIRCLE NO. 97 ON FREE INFORMATION CARD

OK WIRE WRAP DISPENSER

The new WD Series Wire Wrap wire dispenser from OK Machine and Tool Corp. features a unique cutting and stripping capability. Wire is drawn out of the dispenser to the required length. Then a built-in plunger cuts the wire free, while a pull on the cut wire through the stripping blade removes the insulation without nicking the wire. The other end of the wire is just as neatly and quickly stripped away. The dispenser comes with a 50' (15-m) spool of AWG 30 (0.25-mm) industrial-quality Kynar[®] insulated silver-plated solid copper wire. Insulation is available in blue, white, red, and yellow. The dispenser is reusable when the wire runs out simply by inserting a new spool.

CIRCLE NO. 98 ON FREE INFORMATION CARD

JVC PORTABLE/HOME CASSETTE DECK

JVC America's Model CD-1636 portable/home stereo cassette deck, with its new super ANRS, is said to have reduced tape hiss and expanded dynamic range at high frequencies. A monitor speaker for field use is built-in. The deck is designed to operate for up to 12 hours with D-size batteries, but will

also operate from a 120 V ac power source for home use. Features include dual VU meters and battery condition checker, 3-digit tape counter with reset button, automatic tape stop, Sen-Alloy tape head for record/play and ferrite head for erase. Signal-to-noise ratio is rated at 54 dB, improved by 10 dB above 5 kHz with ANRS; wow and flutter, 0.08% rms; THD, 1.2% at 0 VU with standard tape, 1.5% with chrome tape. Frequency response is 45 Hz to 16 kHz \pm 3dB (chrome). Weight is 10.1 lbs. Measurements are 14 $\frac{1}{2}$ "W \times 9 $\frac{5}{8}$ "D \times 3 $\frac{7}{8}$ "H (37 \times 24 \times 10 cm). \$350.

CIRCLE NO. 99 ON FREE INFORMATION CARD

TURNER AM/FM/CB CAMOUFLAGE ANTENNA

A new "camouflage" AM/FM/CB antenna that features a new, easy-to-install design is available from Turner Division of Conrac Corp. The Model SK750 antenna is made to look and function like any other auto antenna, but provide full 40-channel coverage on CB with minimal VSWR. It has a removable 42" (106.7-cm) stainless steel whip and a mounting that adapts to sloping surfaces. The filters in the hermetically sealed watertight housing act as "band separators" to keep the AM/FM and CB signals from mixing. Suggested retail price is \$25.00. (The same antenna configuration is also available for CB only as the Model SK755 for \$19.95.)

CIRCLE NO. 100 ON FREE INFORMATION CARD

Aircommand 40-channel CB...



From the people who bring you Marantz—the world's finest stereo systems—comes the Aircommand CB-640—the finest in 40-channel CB. With Aircommand you get over 25 years experience in outstanding 2-way communications products.

Full 6 Watts of audio power. Provides plenty of punch so your speaker cuts through freeway noise.

Dual-conversion superheterodyne receiver with dual-cascaded ceramic filters. Together, both features provide the most complete rejection of unwanted signals, assuring you unsurpassed selectivity and sensitivity.

4 big Watts of RF power. Aircommand delivers the maximum power legally allowable to let you belt out the big sound.

100% modulation capability. Even when you talk softly into the mike, your message cuts through loud and clear, thanks to one of the most advanced mike preamp and compressor designs in CB today. With Aircommand, you don't have to spend an extra \$30 to \$40 on a "power mike." You can't buy better modulation than Aircommand.

Specially tailored frequency response.

LED 40-channel selection display. Easy-to-read, night or day.

8-LED (light emitting diode) meter display. Provides an easy-to-read display of SWR (standing wave ratio), modulation, and incoming or outgoing signal strength—instantly, accurately.

Special emergency Channel 9 scan with exclusive Aircommand "beep" alert. No matter what channel you're on, a special Aircommand CB-640 circuit continuously and silently monitors Emergency Channel 9. When someone starts transmitting on Channel 9, a unique "beep" alerts you, so you can tune yourself in and give assistance.

Public address capability. The versatile Aircommand CB-640 public address package lets you (1.) Talk into the CB mike and out an exterior public address speaker. (2.) Attach a tape recorder to the auxiliary jack on the



New Literature

CB INTERFERENCE CURES

Electronic Specialists offers a flyer describing cures for common FM, TV and audio interference caused by CB radios. Featured are solutions to problems such as interference picked up by stereo speaker leads and hi-fi phono inputs, and interference conducted over ac power lines. Address: Electronic Specialists Inc., Box 122, Natick, MA 01760.

RCA REPLACEMENT GUIDE

RCA offers its 1977 Solid State Replacement Guide, SPG-202T. The new 195-page guide cross references more than 123,000 solid-state devices, transistors, rectifiers, thyristors and IC's that can be replaced with RCA SK-Series types. Features of the publication are an index of SK-Series semiconductors and accessories, application information, line

drawings of dimensional outlines and terminal arrangements, and a listing of mounting hardware. Cost, \$1.50. Address: RCA Distributor and Special Products Div., PO Box 85, Rùnnemed, NJ 08078.

SILTRONIX ANALOG SWITCH HANDBOOKS

Two new publications from Siltronix facilitate analog switch system design. The first, titled "Analog Switches and Their Applications," is a 352-page handbook covering the theory and practical application of analog switches. It begins with an explanation of FET switch characteristics and driver circuits and moves on to multiplex systems, signal conversion, and n-path filters. Cost \$4.00. The second, "High Speed CMOS Analog Switches," is a 20-page catalog of Siltronix's DG3000 series CMOS analog switches. Available free. Address: Marketing Services Dept., Siltronix, Inc., 2201 Laurelwood Rd., Santa Clara, CA 95054.

MARINE RADIOTELEPHONE CATALOG

A new booklet from Motorola describes its line of Triton marine radiotelephones. Featured are the Triton 55/75, a fully synthesized unit with simplified channel identification, and the Triton SSB marine radiotelephone, which has FM reliability at distances greater than 30-40 miles. Other models described are

bridge-to-bridge marine radio telephones, vhf-FM limited Coast Guard Station models, and FM portables. Accessories are also listed. Address: Motorola Communications Group, Literature Distribution center, 1301 E. Algonquin Rd., Schaumburg, IL 60196.

MEMOREX VIDEO TAPE NEWSLETTER

Understanding the video picture is the topic of Vol. 3, No. 1 of SCAN, a 4-page newsletter for video-tape users offered by Memorex. The issue discusses how a video picture is created within a monitor/receiver and gives tips on troubleshooting the video playback system. Address: SCAN, Memorex Corp., PO Box 420, Santa Clara, CA 95052.

NEDA 1977 BATTERY INDEX

The National Electronic Distributors Association (NEDA) offers the 1977 Battery Index. A replacement guide for over 182 battery types, the index uses number suffixes to list batteries according to their group; rechargeable NiCd batteries and various groups of non-rechargeable types. Major manufacturers included are Bright Star Industries, Eveready, Mallory, Burgess, Inc., and Ray-O-Vac. Price 50 cents. Address: National Electronic Distributors Association (NEDA), 3525 W. Peterson Ave., Suite 601, Chicago, IL 60659.

...You never heard it so good!!!

CB-640 rear panel, and boom your tape out through the same external speaker. (3.) Mix your voice from the CB microphone with the program material on the tape recorder. Both voice and tape sound at the same time through the external speaker. (4.) Beam your received signal through the external speaker.

Built-in standing wave ratio circuitry. Measures the efficiency of the antenna system for optimum performance.

Other outstanding features include: Delta fine tuning control, digital synthesizer with phase-locked loop,

automatic noise limiting switch, noise blanking switch, squelch control, RF gain control.

Also available: Aircommand CB-140; Aircommand CB-340. All 3 units bring you state-of-art design, flawless craftsmanship and day-in, day-out reliability. Try them out now at your Superscope Aircommand dealer.

Aircommand by **SUPERSCOPE**

Selected for use by the California Highway Patrol.



© 1977 Superscope, Inc., 20525 Nordhoff St., Chatsworth, CA 91311. Prices and models subject to change without notice.

Need a 3½ digit DPM?

Build your own LED or LCD panel meter and tailor it to fit your system.

No external active components.
Only 7 passive components needed
for an operating DPM.

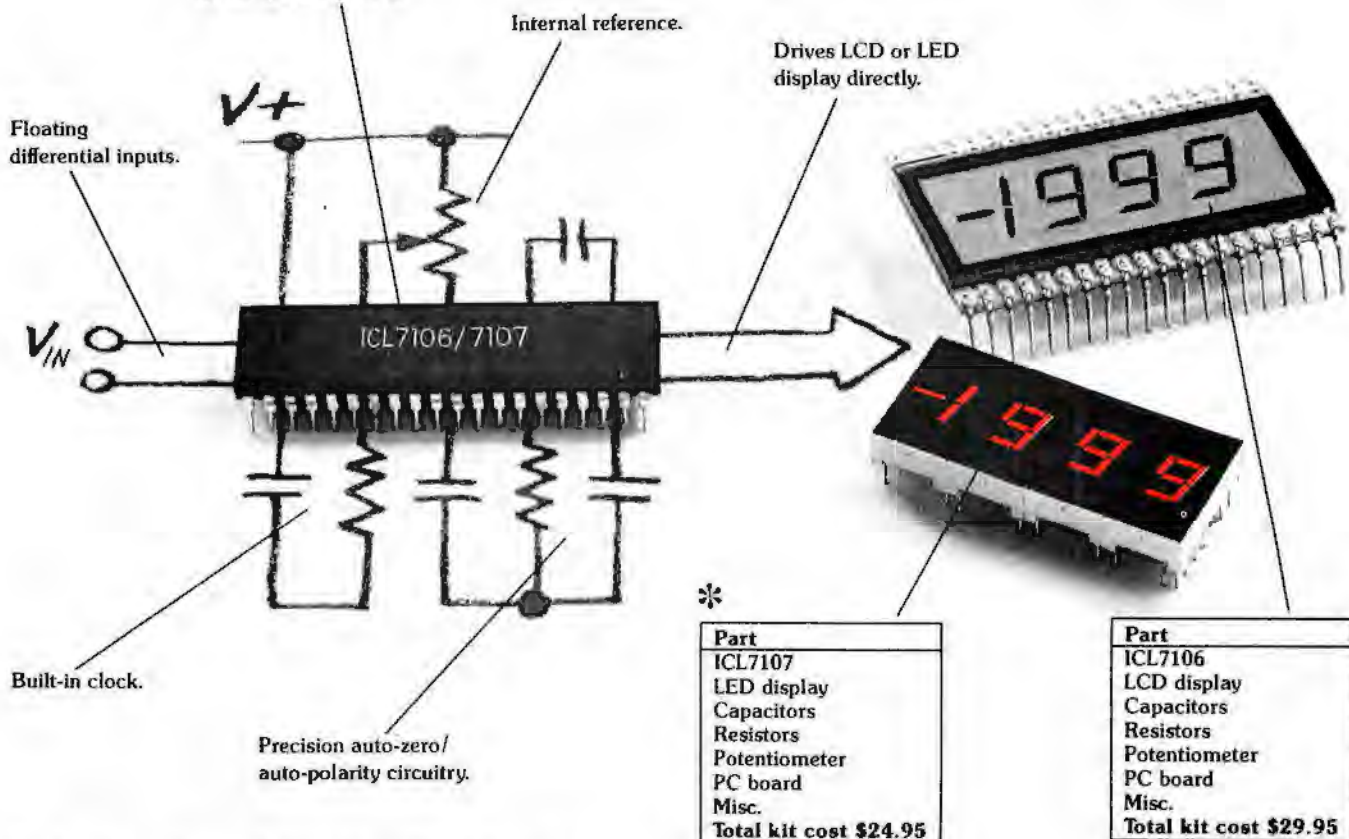

*

Part
ICL7107
LED display
Capacitors
Resistors
Potentiometer
PC board
Misc.
Total kit cost \$24.95

Part
ICL7106
LCD display
Capacitors
Resistors
Potentiometer
PC board
Misc.
Total kit cost \$29.95

Order from Intersil Stocking Distributors.

Arizona Phoenix: Liberty, (602)257-1272; Weatherford, (602)272-7144. **California** Anaheim: Weatherford, (714)547-0891, 633-9633. Costa Mesa: Schweber, (714)556-3880. El Segundo: Liberty, (213)322-8100. Glendale: Weatherford, (213)849-3451. Mountain View: Elmar, (415)961-3611. Pomona: Weatherford, (714)623-1261. San Diego: Liberty, (714)565-9171. Weatherford, (714)278-7400. Sunnyvale: Intermark, (408)738-1111. **Colorado** Commerce City: Elmar, (303)287-9611. Englewood: Weatherford, (303)761-5432. Wheatridge: Century, (303)424-1985. **Connecticut** Danbury: Schweber, (203)792-3500. Hamden: Arrow, (203)248-3801. **Florida** Clearwater: Diplomat/Southland, (813)443-4514. Hollywood: Schweber, (305)927-0511. Ft. Lauderdale: Arrow, (305)776-7790. **Georgia** Atlanta: Schweber, (404)449-9170. **Illinois** Elk Grove Village: Schweber, (312)593-2740. **Indiana** In-

dianapolis: Advent, (317)297-4910. **Maryland** Baltimore: Arrow, (301)247-5200. Rockville: Schweber, (301)881-3300. **Massachusetts** Billerica: Kierulff, (617)667-8331. Waltham: Schweber, (617)890-8484. Woburn: Arrow, (617)933-8130. **Michigan** Farmington: Sheridan, (313)447-3800. Troy: Schweber, (313)583-9242. **Minnesota** Bloomington: Arrow, (612)887-6400. Eden Prairie: Schweber, (612)941-5280. **Missouri** Kansas City: L-Comp, (816)221-2400. **Maryland Heights**: L-Comp, (314)291-6200. **New Jersey** Moorestown: Arrow, (609)235-1900. Somerset: Schweber, (201)469-6008. Totowa: Diplomat IPC, (201)785-1830. **New Mexico** Albuquerque: Century, (505)292-2700. **New York** Binghamton: Harvey Federal, (607)748-8211. Farmingdale: Arrow, (516)694-6800. Hauppauge: Components Plus, (516)231-9200. Rochester: Schweber, (716)461-4000. Westbury: Schweber,

Put it all together for as little as \$24.95*

Intersil's new single chip 3½-digit 7106 and 7107 A/D converters for LCD or LED displays.

Meet the latest in A/D converters: Intersil's 7106, the first single-chip CMOS A/D for driving LCD displays—including backplane—directly.

And the 7107, first single-chip CMOS A/D for driving instrument-size LED displays directly without buffering.

Each provides parallel seven segment outputs, ideal for DVMs, DPMs and anywhere modern digital displays are needed.

Both new devices provide cost advantages over multi-chip designs, because they require no additional active components. Both have internal reference and clock, and both are CMOS so you get low noise (12 to 15 μ V) comparable with the finest bipolar devices, and low power (10mW max. @ 10V). A few more features:

- ± 1 -count accuracy over the entire ± 2000 -count range.
- Guaranteed to read Zero for 0 Volts input.
- Provides true polarity at Zero count for precise null detection.
- Differential input from 200mV to 2.000V full scale.

Build a working DPM in ½ hour with these complete evaluation kits.

Test these new parts for yourself with Intersil's low-cost prototyping kits, complete with A/D converter and LCD display (for the 7106) or LED display (for the 7107). Kits provide all materials, including PC board, for a functioning panel meter. Available from Intersil stocking distributors.

Kit No. ICL7106EV/KIT (LCD), \$29.95 complete.

Kit No. ICL7107EV/KIT (LED), \$24.95 complete.



(516)334-7474. **North Carolina** Raleigh: RESCO, (919)832-2077. **Ohio** Beachwood: Schweber, (216)464-2970. Cincinnati: Sheridan, (513)761-5432. Dayton: Arrow, (513)253-9176. **Pennsylvania** Horsham: Schweber, (215)441-0600. Pittsburgh: Sheridan, (215)244-1640. **Texas** Dallas: Schweber, (214)661-5010; Weatherford, (214)243-1571. Houston: Schweber, (713)784-3600; Weatherford, (713)688-7406. **Utah** Salt Lake City: Century, (801)972-6969. **Washington** Bellevue: Liberty, (206)453-8300. Seattle: Weatherford, (206)243-6340. **Wisconsin** Oak Creek: Arrow, (414)764-6600. **Canada** Downsview, Ontario: Zentronics, (416)635-2822. Montreal, Quebec: Zentronics, (514)735-5361. Ottawa, Ontario: Zentronics, (613)238-6411. Vancouver, British Columbia: R.A.E. Ind., (604)687-2621.

INTERSIL



Stereo Scene

By Ralph Hodges

RECORDS AND THE VERTICAL ANGLE

WHAT THE world still lacks, surprisingly enough, is a really adequate conceptual model for a record player. To be sure, the overall principles have always been obvious: the groove undulates, thereby wiggling the stylus, which is connected to an electrical generator, etc. But the intimate geometry of the way a record is played, taking place as it does on what is really a submicroscopic scale, remains somewhat obscure. Vinyl indentation affects stylus tracing in ways that are not wholly understood; frictional drag and other forces on the stylus assembly alter the geometry of the tracing and transduction situations in complex ways: the rate of stylus and record wear—and the form in which it manifests itself—is not completely predictable. Periodically there are technical papers written to expand or refute existing theories of stylus-groove interaction, but the ultimately authoritative paper has yet to appear.

Fortunately, we don't have to fully understand the record player to use it. In fact, the system seems to be surprisingly tolerant of human error. A cartridge can be installed in a tonearm in five minutes, using the crudest "eyeballing" techniques for alignment, and almost no one will object to the audible results achieved thereby. Considering that the stylus inhabits a world in which the mi-

niscule wavelengths of visible light are beginning to become significant dimensions, its apparently obliging response to very slapdash alignment is a little unexpected.

In the back of many a well-furbished mind there has always been the nagging idea that this can't be right; that closer attention to record-player alignment *must* result in superior reproduction. The trouble is, no one's been able to demonstrate this to the satisfaction of the record-playing world at large.

The Shreve-Rabco Arm. About a year ago (November 1976) I wrote in this space of a modification to the Rabco SL-8 and SL-8E tonearms performed by Dr. David Shreve (Department of Mathematics, University of Wisconsin). At that time I referred only obliquely to several interesting claims made by Dr. Shreve, among them being that the vertical angle (the "rake angle," as it is often called) at which the stylus impinges on the record surface as viewed from the side is critical to within a very small fraction of a degree.

Dr. Shreve referred to his findings as being totally empirical, and he has never shown any inclination to "dignify" his claims with any nice, neat explanatory theory (although there are some very attractive ones free for the taking). His attitude has always been: "I can demonstrate the phenomenon, and if you can hear it (and apparently everyone has so far) you're free to make of it what you will."

I have been "making what I will" of all this ever since, and my conclusion—supported by the informed opinions of others who have looked into the matter—is that we have at hand a very basic and nontrivial demonstration of how disc-playing systems can be significantly improved.

The Scanning Aperture. Shortly after my first meeting with Shreve, I brought his work to the attention of Mitchell Cotter, founder and chief executive of Verion Audio and a researcher with a long and varied background in many areas of practical and theoretical audio. As it happened, Cotter was already convinced of these effects' existence, although he had not fared notably better than others in demonstrating their audibility. He was, however, somewhat surprised by Shreve's reports on the criticalness of the vertical angle. True, theory seemed to predict this, but theory had not quite been batting 1000 in corresponding to the perceived and/or measurable world of record playing.

What exactly *does* theory seem to predict? I couldn't begin to deal with the complexities here, even if they could be pursued profitably in a nonmathematical presentation. But some of the individual effects can be mentioned. Imagine viewing the stylus (a Shibata or other type of "line-contact" CD-4 stylus) from the side as it traces a record groove. If the rake angle is correct, the stylus' contact line will be parallel with the modulation angle of the groove. If it is not, the upper part of the stylus will either lead or lag the lower part in tracing the groove.

So far the situation seems analogous to tape-head alignment. When the azimuth of a playback head is disturbed, the "scanning aperture" corresponding to its gap becomes effectively wider, and high-frequency response begins to fall off in the same way as it would if the gap were physically wider. However, while the "effective" edge of the stylus is also a scanning aperture, a simple loss of high-frequency response is not the only predictable result of incorrect rake angle. Whether azimuth is right or not, a tape head is always scanning the flat plane of the tape surface. The stylus "sees" a flat plane from a modulated groove only when its rake angle is absolutely on the button. Otherwise it traces—or tries to trace—a curvature that can become rather complex, with the skewed contact line of the stylus doing its best to strike a rough average between the various groove contours it is encountering. Also, groove curvature is a definite factor in stylus indentation of the record material, so that a further ambiguity in tracing is introduced.

At this point, let's consider the several dimensions in which a stylus moves. Ideally, all its excursions take place within a curved plane—a section of the shell of a sphere that has its center at the sty-

(continued on page 20)

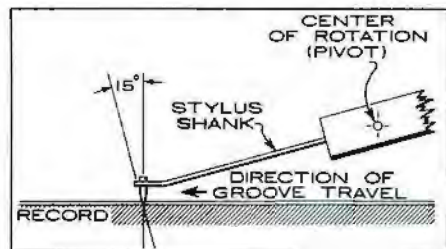

Diagram shows vertical tracking angle and stylus pivot point.

Precision and elegance. The newest Quartz-Servo by Sansui.

Introducing the Sansui SR-838, a luxurious new direct-drive turntable that performs silently with rare and fine precision. Free from howl and feedback, the SR-838 complements the superior tonal quality and the exacting standards of today's most sophisticated component systems.

The SR-838 Quartz-Servo direct-drive system delivers phono reproduction so accurate it may astonish you. By locking motor speed to the precise control of a highly refined quartz crystal, Sansui engineers have achieved platter speed deviation of less than 0.002%, and unusually low wow and flutter of less than 0.025%.

Sansui engineers have also designed a unique new tonearm for the SR-838. It features a Mass-Concentrated Fulcrum design, with wide-set pivot points, to suppress unwanted front-back/left-right vibrations. Inside the tubular tonearm is a special resin* that prevents resonance. And the entire unit is firmly mounted on a zinc die-cast base for the most stable performance you can find.

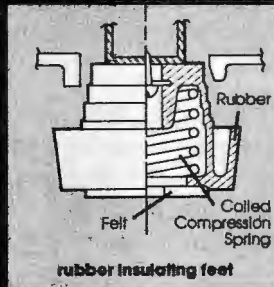

The Sansui SR-838 offers all the performance advantages you'd expect from a superior turntable, plus more. Such as fine pitch control, an electronic brake for speed changes, a skating force canceller, and an oil-damped cueing lever. And the newly designed rubber insulating feet provide superior feedback isolation.

To top it all, the SR-838 is a feast for the eyes as well as the ears. All controls are positioned up front for easy access and operation. And the satin piano lacquer finish glows with the elegance of simplicity.

See the SR-838, at less than \$390**, including base and dust cover, at your nearest franchised Sansui dealer. Hear it, and you'll discover that advanced technology and precision design do indeed make a difference in the world.

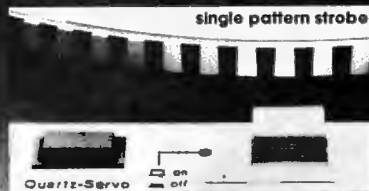

Learn digital computer

NRI is the only school to train you at home on a real digital computer.

Learn computer design, construction, maintenance and programming techniques on your own programmable digital computer.

Qualified technicians are urgently needed for careers in the exciting new field of digital and computer electronics . . . and the best way to learn digital logic and operations is now available to you in NRI's Complete Computer Electronics Course.

This exclusive course trains you at home on your own digital computer! This is no beginner's "logic trainer", but a complete programmable digital computer that contains a memory and is fully automatic. You build it yourself and use it to define and flow-chart a program, code your program, store your program and data in the memory bank. Press the start button and the computer solves your problem and

displays the result instantly.

The NRI digital computer is one of 10 kits you receive in the NRI Complete Computer Electronics Course. You build and use your own TVOM, and experiment with NRI's exclusive Electronics Lab. You perform hundreds of experiments, building hundreds of circuits, learning organization, operation, trouble-shooting and programming.

New NRI Memory Expansion Kit

The Model 832 NRI Digital Computer now comes with a new Memory Expansion Kit. Installed and checked out in 45 minutes, it doubles the size of the computer's memory, significantly increasing the scope and depth of your knowledge of digital computers and programming. With the large-scale IC's you get the only home training in machine language programming . . . experience essential to trouble-shooting digital computers.



electronics at home.

NRI offers you five TV/Audio Servicing Courses

NRI can train you at home to service Color TV equipment and audio systems. You can choose from 5 courses, starting with a 48-lesson basic course, up to a Master Color TV/Audio Course, complete with designed-for-learning 25" diagonal solid state color TV and a 4-speaker SQ™ Quadraphonic Audio System. NRI gives you both TV and Audio servicing for hundreds of dollars less than the two courses as offered by another home study school.

All courses are available with low down payment and convenient monthly payments. All courses



provide professional tools and "Power-On" equipment along with NRI kits engineered for

training. With the Master Course, for instance, you build your own 5" wide-band triggered sweep solid state oscilloscope, digital color TV pattern generator, CMOS digital frequency counter, and NRI electronics Discovery Lab.



*Trademark of CBS Inc.

NRI's Complete Communications Course includes your own 400-channel VHF transceiver

NRI's Complete Communications Course will train you at home for



one of the thousands of service and maintenance jobs opening in CB; AM and FM trans-

mission and reception; TV broadcasting; microwave, teletype, radar, mobile, aircraft, and marine electronics. The complete program includes 48 lessons, 9 special reference texts, and 10 training kits. Included are: your own "designed-for-learning" 400-channel VHF transceiver; electronics Discovery Lab™; CMOS digital frequency counter; and more. You also get your all

important FCC Radio-telephone License, or you get your money back.



CB Specialist Course also available



NRI also offers a 37-lesson course in CB Servicing with your own CB Transceiver, AC power supply, and multimeter. Also included are 8 reference texts and 14 coaching units to make it easy to get your Commercial Radiotelephone FCC License.

You pay less for NRI training and you get more for your money.

NRI employs no salesmen, pays no commissions. We pass the savings on to you in reduced tuitions and extras in the way of professional equipment, testing instruments, etc. You can pay more, but you can't get better training.

More than one million students have enrolled with NRI in 62 years.

Mail the insert card and discover for yourself why NRI is the recognized leader in home training. Do it today and get started on that new career. No salesman will call.

If card is missing write:

NRI NRI SCHOOLS
 McGraw-Hill Continuing
 Education Center
 3939 Wisconsin Avenue
 Washington, D.C. 20016

lus's pivot point. Also ideally, the shell is almost infinitely thin. However, especially in the case of a line-contact stylus, an error in rake angle "thickens" the shell, with resulting phase-time ambiguities. Such errors are inevitable; even vertical stylus excursions produce them. But at what point, if any, do they become audibly detrimental? And what is their effect when they combine with other errors in tracing geometry?

The Listening Approach. Since the means (the Shreve/Rabco arm) seemed to be at hand, we decided to let theory rest for the time being and work toward empirical findings with listening tests. The Rabco SL-8/SL-8E arm, as you may be aware, is (or was; it is no longer made) a radial-tracking mechanism. The arm carriage transits on an aluminum track that has vertical screws at either end to facilitate height and levelling adjustments. Thus the stylus rake angle can be varied minutely and repeatably even while a record is playing, without doing any great violence to other parameters of cartridge alignment (we invariably found ourselves working with a range of rake angles spanning considerably less than a degree of difference). This, plus its other refinements, made the arm a viable experimental tool in our judgment.

Once we (Dr. Shreve, Mitchell Cotter, and I, for the most part) had confirmed that we could hear these seemingly small differences and could agree on what the "right" sound was, we evolved individually for the most part, but with close agreement later on) a number of working hypotheses.

(1) The optimum vertical adjustment should not be the same for every record. Variables such as different record-cutter geometries, different cutting practices, and even different record thicknesses would logically prevent this.

(2) A warped record should make the optimum vertical adjustment less easy to achieve, if it could be achieved at all.

(3) Adjusting the carriage track of the arm so that it is not quite parallel with the record surface should result in a change of vertical angle over the record side, and therefore a change in the "sound." (It would also result in slight changes of other alignment parameters; the big questions concerned which changes, if any, would be most audible.)

(4) A true line-contact CD-4 stylus should be quite critical to adjust; and once properly adjusted, it might conceivably yield performance superior to that of a "conventional" stylus.

(5) A change in stylus force should change the rake angle, and hence the "sound."

After about a year of listening, our general observations are as follows.

(1) The optimum vertical angle is not the same for every record. With the records we have sampled we've encountered a range of "optima" spanning a mere 25 minutes (!) of arc. However, some records audibly perform quite badly when used with a different record's optimum setting, although they may sound very good when individually compensated for.

(2) Warped records are not as difficult to adjust for as anticipated. An attempt at explaining this must await further work. It is true that we've not been extraordinarily successful in obtaining warped and unwarped copies of the same record. It almost appears that a given release is either unwarped or warped, although the warps are usually not the same. We have not attempted to deliberately warp any records.

(3) Making the carriage track nonparallel to the record surface alters the sound over a record side in an identifiable way. Deliberately misaligning the effective length of the radial arm to create a similar change in lateral tracking-angle error over the record side does not seem to alter the sound as recognizably. But this test lacks a certain amount of rigor.

(4) CD-4 styli are typically easier to set at optimum vertical angle; the "optimum" is much less ambiguous. When so set, they consistently (audibly) outperform comparable cartridge models fitted with spherical or "conventional" bi-radial stylus tips.

(5) Altering the vertical stylus force seems to produce the expected change in "sound." In fact, in some cases small changes in stylus force have seemed to be as effective as small changes in vertical angle in achieving the most listenable results. (In all cases the stylus-force changes have been very small, and always well within the recommended tracking-force range of the cartridge's manufacturer. Measurement of the force, with one exceptional instance, has always been consistently repeatable with the Shreve arm and a tracking-force gauge of high reliability and resolution [within 1/10 gram].)

And What Is the Sound? While we agree when the verticle adjustment is correct to our ears, we do not always use the same language to describe what we hear when it is not to our liking. High

frequencies are affected most profoundly, to the point where sharp sibilance on voice recordings can be reduced to almost no sibilance. There is a noticeable change in the quality of whatever noise is present on the record, so that it becomes subjectively smoother, less obtrusive, and less troubled by what subjectively seems to be a periodic modulation effect. Whatever stereo perspective is present on the record seems dramatically enhanced, with sharper and stabler positioning of sound sources both left to right and forward to back (although we think we have occasionally discovered "faults" in the stereo perspective of some recordings as a result of optimum adjustment).

The Unanswered Questions. The vertical cutting angle adopted in making a record is established at the discretion of the mastering engineer. A fairly common practice is to use a special test record as a vertical reference while the cutting head is set up. However, we have heard of instances in which the cutter's vertical angle has been slightly modified to achieve a smoother or quieter cut.

The variations in vertical angle from record to record we have found are probably small enough to be accounted for by differences in test records, or even differences in set-up procedures when the same test record is used. However, the precise roles that these and other factors play in the vertical-angle situation are far from clear to us at present.

Several other questions remain. One concerns the matter of deformations in the ideally flat surface of the record, and what part they could or should play in properly defining the correct vertical angle. Another question asks whether there is (as would seem logical) an optimum relationship between rake angle, vertical tracking angle, and stylus force, since the first two would certainly change with an alteration of the third, but not necessarily in the same direction with respect to an optimum adjustment.

Perhaps the ultimate question is whether a significant number of commercially available arms and record players (as opposed to the custom-built and carefully adjusted equipment in our hands) can reveal the effects of these minute variations in alignment. Thanks to Mr. Cotter's efforts, the first tentative answer to this question seems to be moving toward a qualified "yes." And thus it appears certain that you'll have heard far from the last of this matter when you lay down this magazine. ♦



THE INTEGRATED DC AMPLIFIER HAS ARRIVED.

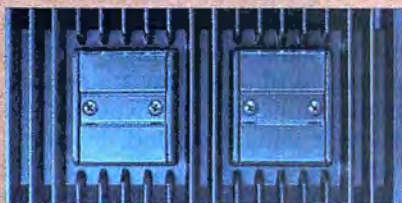

Gone is phase distortion. Gone is time-delay distortion.

The Kenwood KA-9100 integrated DC amplifier is here.

Its response is flat down to 0 Hz. It has three power supplies. The Total Harmonic Distortion is 0.03% over the full frequency range of 20-20k Hz. The Signal-to-Noise ratio is 83 dB at 2.5 mV. It has the best phono sensitivity (0.8 mV) of any integrated amplifier. For better heat dissipation, the KA-9100 has large heat sinks on either side.



It is an amplifier so advanced even the pre-amp has its own power supply.

It is the next generation Kenwood. The unit all others will be measured against. Just as they were when we pioneered dual power supplies.

The KA-9100 integrated DC amplifier. With 90 watts per channel, minimum RMS, at 8 ohms from 20 to 20,000 Hz with no more than 0.03% Total Harmonic Distortion.

And, as if all that wasn't enough, it costs less than \$500.*

KENWOOD

15777 S. Broadway, Gardena, CA 90248 • 72-02 Fifty-First Avenue, Woodside, NY 11377

Handles optional.

*Suggested resale price. Actual prices are established by Kenwood dealers.



Audio Reports

PROS AND CONS OF MULTI-WAY SPEAKER SYSTEMS

IT HAS long been recognized that a single loudspeaker cone cannot properly reproduce the full audible frequency range. Nevertheless, a single speaker is still widely used, as in TV receivers, automobile radios, and low-priced home radios and record players for that impossible task. Here, a degree of effectiveness is made possible only by a reduction in quality standards, which would not be acceptable in a high-fidelity system.

The examples mentioned above cannot be called "hi-fi" by any stretch of the imagination, although sometimes, against all reason, that claim is made for them. Even a minimum quality component speaker system uses at least two drivers to cover the audio range, and more expensive ones divide the audible spectrum into three or even four bands. It is thus quite natural to assume that more separate frequency bands in a speaker system result in better quality.

The foregoing assumption may be natural, but it is not necessarily correct. In fact, in the absence of other information, there is no reason to conclude that a three-way system is better than a two-way system or even as good. To see why this is so, let us consider the reasons for dividing up the reproduction task among several drivers.

To generate appreciable amounts of acoustic power at low frequencies, a large volume of air must be moved by the speaker cone. This can be done by using a large cone area with a relatively small excursion, or a smaller cone with a large excursion. Both methods are capable of good results, but the popular acoustic suspension speakers are based on the latter approach. To get a reasonably flat, smooth bass response, it is not sufficient simply to use the largest possible speaker diameter, or to increase the size of the enclosure. These two factors, together with a host of other speaker parameters, are interrelated. Once a certain performance standard has been decided upon, neither can be changed without a corresponding change in the other. The value of a proper bass speaker design is demonstrated by the many small speakers, with woofers only 6 to 8 inches in diameter, whose bass response extends to 40 Hz or even lower.

A larger cone diameter gives the designer several possible options for improved performance. The lower limit of the speaker's response could be extended (perhaps together with reduced distortion), or its efficiency could be increased. Since nothing in this

world is truly free, what disadvantages might result from such a change?

A woofer cone can deliver its calculated flat response only in the limited frequency range within which it moves as a piston. At higher frequencies, where the speaker diameter becomes an appreciable fraction of the acoustic wavelength, the response becomes irregular, as well as increasingly directional. The massive cone, which is advantageous for a woofer, becomes a liability at higher frequencies. Here, low moving mass is necessary to allow the cone to reverse direction hundreds or even thousands of times each second. Therefore, whatever the size of the woofer, above some selected frequency the signal energy must be diverted from it to another speaker more suitable for that range. The choice of a "crossover" frequency is not entirely arbitrary since it must take into account the high-frequency aberrations in the woofer's response, and the low-frequency limitations of the smaller speaker. A "tweeter," as the high-frequency driver is usually called, is much smaller in diameter than the woofer, and has a much lighter cone and voice coil structure. The low mass allows it to respond more rapidly to high-frequency signals, while its smaller diameter gives the sound a wide polar dispersion instead of "beaming" it forward, as happens when the cone diameter is comparable to the wavelength of the sound. At very high frequencies, even an ordinary tweeter cone may be too large to give the desired response, necessitating a second crossover to a still smaller speaker. This is known as a "three-way" system, in contrast to the simple "two-way" system comprised of a woofer and a single high-frequency driver.

Here are some considerations on the relationship between the size of the several drivers and the choice of crossover frequencies. In a typical small speaker system, with a woofer 8 inches or less in diameter, it is feasible to cross over to the tweeter as high as 2000 Hz, or even higher in some cases. At that frequency, a specially designed dome or small cone tweeter is used instead of merely a miniature version of the woofer. With a cone diameter of 1 to 1½ inches such a speaker can give satisfactory results up to 15,000 Hz or even beyond. While it is possible (and sometimes done) to cross over to a third "super tweeter" at a very high frequency, such as 7,000 to 10,000 Hz, the benefits would be negligible. The high-frequency dispersion

MAGAZINES AT DISCOUNT!

You SAVE up to 50%

Here's your chance for a real bargain bonanza on your favorite magazines. You may select as many as five of these titles at the special introductory rates shown below—up to 50% off! To order, indicate the magazines you want by inserting their code numbers in the boxes on the attached order card. Or write to: MAGAZINES AT DISCOUNT, A Division of Ziff-Davis Publishing Co., P.O. Box 2703, Boulder, Colorado 80322.

CODE NOS.

- (01) **BOATING** You pay only \$7.97
Reg. Rate: 12 Issues for \$12.00
- (70) **CAR CLASSICS** You pay only \$8.98
Newsstand Rate: 6 Issues for \$15.00
- (02) **CAR & DRIVER** You pay only \$4.99
Reg. Rate: 12 Issues for \$9.98
- (03) **CYCLE** You pay only \$4.99
Reg. Rate: 12 Issues for \$9.98
- (71) **FOUR WHEELER** You pay only \$5.49
Reg. Rate: 12 Issues for \$9.50
- (28) **MECHANIX ILLUSTRATED** You pay only \$5.96
Reg. Rate: 18 Issues for \$9.97
- (34) **PLAYBOY** You pay only \$12.00
Newsstand Rate: 12 Issues for \$19.00
- (06) **POPULAR ELECTRONICS** You pay only \$6.99
Reg. Rate: 12 Issues for \$12.00
- (07) **POPULAR PHOTOGRAPHY** You pay only \$4.99
Reg. Rate: 12 Issues for \$9.98
- (35) **POPULAR SCIENCE** You pay only \$5.97
Reg. Rate: 18 Issues for \$11.91
- (08) **PSYCHOLOGY TODAY** You pay only \$6.97
Reg. Rate: 12 Issues for \$12.00
- (56) **ROLLING STONE** You pay only \$9.00
Reg. Rate: 26 Issues for \$18.00
- (09) **SKIING** You pay only \$4.99
Newsstand Rate: 7 Issues for \$8.75
- (11) **STEREO REVIEW** You pay only \$3.99
Reg. Rate: 12 Issues for \$7.98
- (40) **TIME** You pay only \$12.50
Newsstand Rate: 25 Issues for \$25.00
- (41) **TV GUIDE** You pay only \$8.35
Lowest Available Sub. Rate for 32 Issues



might be improved by using a second, smaller tweeter, but the effect is likely to be rather subtle.

Suppose that a larger woofer, 10 or 12 inches in diameter, is used. Such a speaker cannot function optimally much above 1000 Hz, and the crossover to the next driver usually takes place between 500 and 1000 Hz. At that frequency, a small dome tweeter cannot be used either because its light voice coil could easily be burned out by the concentration of program energy in the midrange. Furthermore, the large cone excursions needed would be impractical for such a driver.

To cover this frequency, a larger version of the dome tweeter is sometimes used (this can be expensive). But more frequently, the midrange driver is a conventionally appearing cone unit that's about 3 to 5 inches in diameter. This can handle the midrange power, but its useful upper frequency limit is perhaps several thousand hertz. For full-range reproduction, there is a second crossover to a true tweeter, usually in the 3000-to-5000-Hz range. From this we can see that a speaker based on large low-frequency drivers or designed for use at high volume levels has to have three drivers do what can be done fairly well at lower levels by a smaller two-way system.

Sometimes we encounter four-way systems, although this is a refinement limited to fairly exotic and expensive speakers. Usually, a very small super-tweeter is added to a more conventional three-way system, with a crossover at 10,000 Hz or even higher. Alternatively, the fourth driver can be added at the

low-frequency end, crossing over from the woofer to an upper-bass or lower mid-range driver in the 100-to-300-Hz region. The upper-bass speaker is normally a small woofer that measures about 8 inches in diameter. Together with the higher frequency drivers, it acts as the woofer of a three-way system.

If a super tweeter is used, especially at frequencies near the limits of human hearing, its benefits may be marginal. Little program material has much content in that range, except for noise. Thus, the principal benefit of a super tweeter may be an airier quality due to improved dispersion.

The rationale for using a very low woofer crossover frequency is that the large woofer cone excursions at low frequencies tend to modulate higher frequencies in the program band handled by the woofer. Even if the speaker is perfectly linear, high frequencies radiated by a cone simultaneously handling low frequencies will be frequency-modulated (the Doppler effect). This produces a modulation distortion very much like that resulting from woofer nonlinearity. By restricting the woofer to a narrow frequency range, the likelihood of such intermodulation is reduced. Of course, this places an added burden on the next higher frequency driver, which often carries the bulk of the audible program content and must do so with a minimum of distortion.

We have seen how the number of crossovers in a speaker system is determined by the limitations of its individual drivers, the cabinet size, and the degree of

Great Jumpers are here!

State of the art
flat cable connector assemblies . . .
at affordable prices.

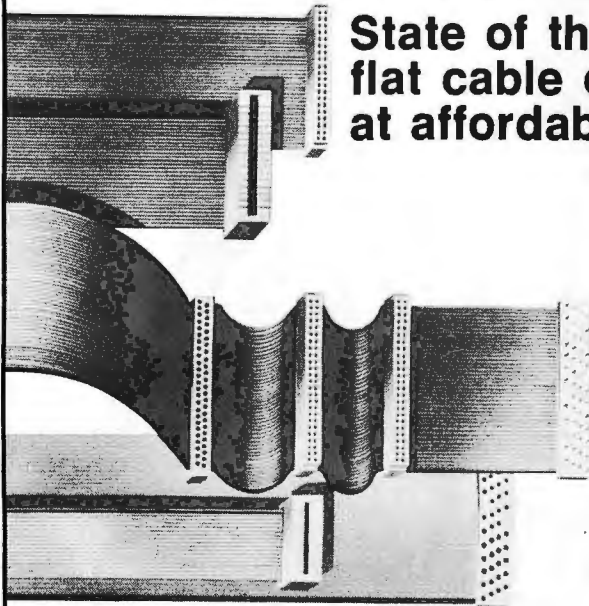

Great Jumpers come to you fully pre-assembled and fully pre-tested. Cable strain reliefs are integral to the molded-on connectors. And we've designed in complete line-by-line probeability with probe access ports behind each contact.

Our connectors are industry standard; two parallel rows of contacts, spaced every .1".

Great Jumpers come in five popular cable widths: 20, 26, 34, 40 and 50 lines wide, and in lengths ranging from 6" to 36".

Available now at the distributor near you who carries the A P Products Faster and Easier Line.

Our distributor list is growing daily. For the name of the distributor nearest you call Toll-Free 800-321-9668.

Send for our complete A P catalog, the Faster and Easier Book.

Faster and easier is what we're all about.



A P PRODUCTS INCORPORATED

Box 110 • 72 Corwin Drive Painesville, OH 44077 (216) 354-2101 TWX: 810-425-2250

Powerful in computing muscle, yet small in physical size, the Altair™680b offers many special features at an affordable price. Based on the 6800 microprocessor, the 680b comes with 1K of static RAM, Serial I/O port, PROM monitor and provisions for 1K of PROM as standard components. It's good thinking, when you're interested in making a modest investment on a highly reliable computer, to consider the Altair 680b.

Our PROM monitor eliminates the necessity for toggling front panel switches to load bootstraps or manipulate memory contents. Only a terminal and programming language are required for complete system operation. With Altair System software—Altair 680 BASIC, assembler and text editor—you may begin problem solving immediately with ease.

By adding the 680b-MB Expander card, many options are currently available:

*16K Static Memory Board—Increase your system memory with 16K bytes of fast access (215 ns), low power (5 watts per board) static RAM. 680 BASIC and assembler/text

editor are included free with purchase.

*Process Control Interface—A PC card that uses optically isolated inputs and relay outputs that transmit sensory information to and control signals from the computer. A diverse world of control applications is opened up with the Altair 680b-PCI.

*Universal Input/Output Board—If your I/O needs exceed the serial port already on the main board, augment your I/O channels with the 680b-UI/O. By implementing the optional serial port and two parallel ports, you can simultaneously interface to four terminals.

*New Addition—Kansas City Audio Cassette Interface—Use the 680b-KCACR to interface your Altair 680b with an audio cassette recorder for inexpensive mass storage of programming languages, programs and data.

Available in either full front panel or turnkey models, the Altair 680b presents many computing capabilities at a low cost—without skimping on performance. See it today at your local Altair Computer Center or contact the factory for further details.



Good Thinking.



2450 Alamo S.E. Albuquerque, New Mexico 87106
dealer inquiries invited.

At CIE, you get electronics career training from specialists.

If you're interested in learning how to fix air conditioners, service cars or install heating systems – talk to some other school. But if you're serious about electronics, come to CIE – The Electronics Specialists.

John E. Cunningham

**Special Projects Director
Cleveland Institute of Electronics**

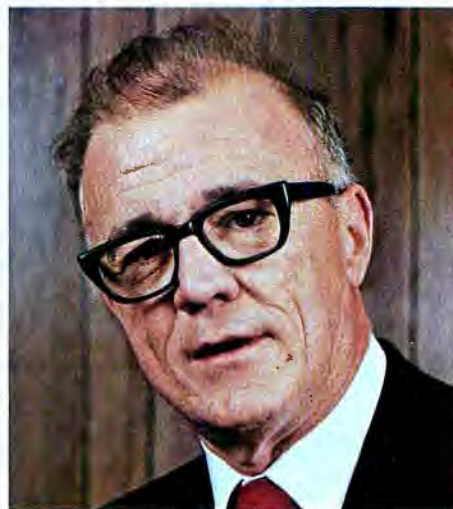

My father always told me that there were certain advantages to putting all your eggs in one basket. "John," he said, "learn to do one important thing better than anyone else, and you'll always be in demand."

I believe he was right. Today is the age of specialization. And I think that's a very good thing.

Consider doctors. You wouldn't expect your family doctor to perform open heart surgery or your dentist to set a broken bone, either. Would you?

For these things, you'd want a specialist. And you'd trust him. Because you'd know if he weren't any good, he'd be out of business.

Why trust your education and career future to anything less than a specialist?

You shouldn't. And you certainly don't have to.

FACT: CIE is the largest independent home study school in the world that specializes exclusively in electronics.

We have to be good at it because we put all our eggs in one basket: electronics. If we hadn't done a good job, we'd have closed our doors long ago.

Specialists aren't for everyone.

I'll tell it to you straight. If you think electronics would make a nice hobby, check with other schools.

But if you think you have the cool—and want the training it takes—to make sure that a sound blackout during a prime time TV show will be corrected in seconds—then answer this ad. You'll probably find CIE has a course that's just right for you!

At CIE, we combine theory and practice. You learn the best of both.

Learning electronics is a lot more than memorizing a laundry list of facts about circuits and transistors. Electronics is interesting because it's based on some fairly recent scientific discoveries. It's built on ideas. So, look for a program that starts with ideas—and builds on them.

That's what happens with CIE's Auto-Programmed® Lessons. Each lesson uses world-famous "programmed learning" methods to teach you important principles. You explore them, master them completely... before you start to apply them!

But beyond theory, some of our courses come fully equipped with the electronics gear to actually let you perform hundreds of checking, testing and analyzing projects.

In fact, depending on the course you take, you'll do most of the basic things professionals do every day—things like servicing a beauty of a Zenith color TV set... or studying a variety of screen display patterns with the help of a color bar generator.

Plus there's a professional quality oscilloscope you build and use to "see" and "read" the characteristic waveform patterns of electronic equipment.

You work with experienced specialists.

When you send us a completed lesson, you can be sure it will be reviewed and graded by a trained electronics instructor, backed by a team of technical specialists. If you need specialized help, you get it fast... in writing from the faculty specialists best qualified to handle your question.

People who have known us a long time, think of us as the "FCC License School."

We don't mind. We have a fine record of preparing people to take... and pass... the government-administered FCC License exams. In fact, in continuing surveys nearly 4 out of 5 of our graduates who take

the exams get their Licenses. You may already know that an FCC License is needed for some careers in electronics—and it can be a valuable credential anytime.

Find out more! Mail this card for your FREE CATALOG today!

If the card is gone, cut out and mail the coupon.

I'll send you a copy of CIE's FREE school catalog, along with a complete package of independent home study information.

For your convenience, I'll try to arrange for a CIE representative to contact you to answer any questions you may have.

Remember, if you are serious about learning electronics... or building upon your present skills, your best bet is to go with the electronics specialists—CIE. Mail the card or coupon today or write CIE (and mention the name and date of this magazine), 1776 East 17th Street, Cleveland, Ohio 44114.



Patterns shown on TV and oscilloscope screens are simulated.

CIE Cleveland Institute of Electronics, Inc.
 1776 East 17th Street, Cleveland, Ohio 44114
 Accredited Member National Home Study Council

YES... John, I want to learn from the specialists in electronics—CIE. Send me my FREE CIE school catalog—including details about troubleshooting courses—plus my FREE package of home study information. **PE-42**

Print Name _____

Address _____ Apt. _____

City _____

State _____ Zip _____

Age _____ Phone (area code) _____

Check box for G.I. Bill information: Veteran Active Duty

Mail today!

subjective refinement that is desired. (It is difficult, if not impossible, to actually measure the benefits of some multi-way speaker systems, especially in view of the aberrations introduced by any crossover network, let alone a four-way network.)

Having made side-by-side comparisons between two- and three-way systems based on similar drivers and cabinet dimensions, we can attest to the added openness imparted by a good three-way design. It is a fairly subtle effect, however, and might not be detectable without such a comparison. On the other hand, we have often been impressed by the similarity in sound quality between some good, small two-way speaker systems and vastly larger (and more expensive) three- or four-way systems. There is not much mystery to this effect, since it means that the speakers involved have been designed to give a uniform energy response with better than average dispersion. Their similarity is clearly evident in the measured frequen-

cy response. Consequently, it is not surprising that they sound very much alike in their basic octave-to-octave balance and freedom from coloration. The low-frequency limitations of the small speakers are usually evident only below 50 Hz or so, where most programs have little energy.

The Speakerlab 7 speaker reviewed here is a three-way system, and from its use of two full-size (10- and 12-inch) woofers it is easy to understand why a three-way design was necessary. The first crossover at 700 Hz was dictated by the high-frequency limitations of the woofers, and a rather large horn driver was needed in the midrange to operate down to that frequency. A horn of this size cannot do a good job at the highest audio frequencies, making it necessary to cross over to a second smaller horn at 5000 Hz. A speaker with the efficiency and power handling ability of this one could not have been made with a simple two-way configuration or in a smaller cabinet. ◇



AKAI MODEL GX-270D-SS FOUR-CHANNEL TAPE RECORDER

Synchronous recording function permits multitrack taping.



Paradoxically, at a time when interest in quadraphonics is not especially strong,

a number of open-reel tape recorders on the market feature 4-channel capabilities. The indication here is that home recordists are using these decks to build up multitrack recordings in a manner similar to that used by professional recording studios, rather than for recording and listening to 4-channel tapes.

Akai's Model GX-270D-SS 4-channel open-reel tape recorder is in this category, having the synchronous recording capability that makes it possible to obtain multitrack recordings. Its "Quadra Sync" recording system can be used in both the 2- and 4-channel modes. The deck also features a direct-driven cap-

stan, 7½- and 3¾-ips (19.1 and 9.5 cm/s) speeds, and a bidirectional playback feature for stereo operation. The transport is solenoid controlled.

The recorder measures 18.3"H × 17.3"W × 7.5"D (46.5 × 44 × 19.5 cm) and weighs 39.2 lb (17.8 kg). Its nationally advertised value is \$875.

General Description. An ac servo motor is used to directly drive the capstan of the recorder, eliminating the belts and pulleys usually found in tape drives. Pushbutton switches are used to select the operating speed and simultaneously switch in the appropriate equalization characteristic. The hubs can accommodate tape reels up to 7" (17.8 cm) in diameter. Each hub is driven by its own eddy-current motor.

The bidirectional playback mechanism can be initiated either automatically by conducting foil on the tape's leader or manually by pressing a switch. The main transport functions are controlled by six pushbutton switches, through solenoid actuators. They include normal and fast speeds in both directions, STOP, and REC interlock functions. A "flying start" recording can be made from play by simultaneously holding down the normal play button and pressing the REC button. A separate PAUSE button stops the tape without disengaging the recording function.

A small PITCH CONTROL knob to the left of the tape heads can be used to adjust the tape speeds over a nominal ±5% range. It has a detented center position, which gives the nominally correct tape speed. This control operates when the transport is in both the record and the playback modes. So, it can be used to correct the pitch of a reference track when making a Quadra Sync recording. Below the PITCH CONTROL are the POWER switch and two TAPE SELECTOR buttons (for low-noise and wide-range tapes) and the speed selector buttons.

There are five pushbuttons in the Quadra Sync system. Four are for individual channel selection and the fifth allows you to select either the 2- or the 4-channel mode of operation.

Four VU meters light according to the mode selected. In the 2-channel mode, only the channels 1 and 3 meters light, while in the 4-channel mode, all four meters light. A red light above each meter glows when that channel is in the recording mode. This gives a very clear indication of the operation of the Quadra Sync system, since pressing any of the system's buttons disables the erase and record function for that channel, simultaneously extinguishing the corresponding red light.

The settings of the concentric playback level controls do not affect the meter readings. A MONITOR switch con-

President. Better than CB really has to be.

Nobody needs a 134 MPH sports car to get to work and back. And you probably don't need a CB as good as a President. But maybe...just maybe...you want one.

You want 40 channels. You want all the little extras like variable mike gain, delta tune, LED channel readout and ANL.

Every single President CB—not just one in twenty—is thoroughly tested to make sure it works perfectly before it leaves the factory.

And every single President

CIRCLE NO. 50 ON FREE INFORMATION CARD



incorporates high technology like IC chips and our new compression circuit for superior talk power.

Maybe we've gone too far with the simple CB. But maybe... just maybe...you won't settle for anything less.

PRESIDENT

Engineered to be the very best.

President Electronics, Inc.
16691 Hale Avenue - Irvine, CA 92714 - (714) 556-7355
In Canada: Lectron Radio Sales Ltd., Ontario



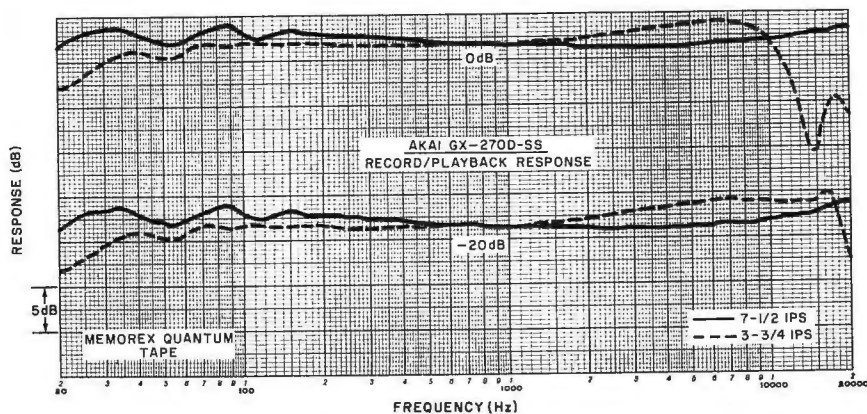

Record/playback response using Memorex Quantum tape at 7½ and 3¾ ips.

nects either the input signal or the playback amplifier output to the line output terminals. Four separate ¼" (6.4-mm) phone jacks are provided for the microphones, which should be medium impedance (600-ohm) dynamic types. There are also two stereo phone jacks for monitoring the front and rear channels. For best results, the phones should have an 8-ohm impedance. Below each VU meter is a concentric pair of recording level controls for that meter's channel (one each for the MIC and line inputs, which can be mixed).

On the rear of the recorder are the four pairs of line inputs and outputs and a socket for an optional remote control accessory.

The specifications of the Model GX-270D-SS are consistent with the requirements for a high-quality home tape recorder. Based on the use of Scotch 211 or an Akai tape, they include: frequency response to 21,000 Hz at 7½ ips and to 15,000 Hz at 3¾ ips; with wow and flutter less than 0.07% and 0.1% at the two speeds; less than 1% distortion at 1000 Hz and 0 VU; and better than 54 dB S/N ratio, referred to a +6-VU recording level.

Laboratory Measurements. The

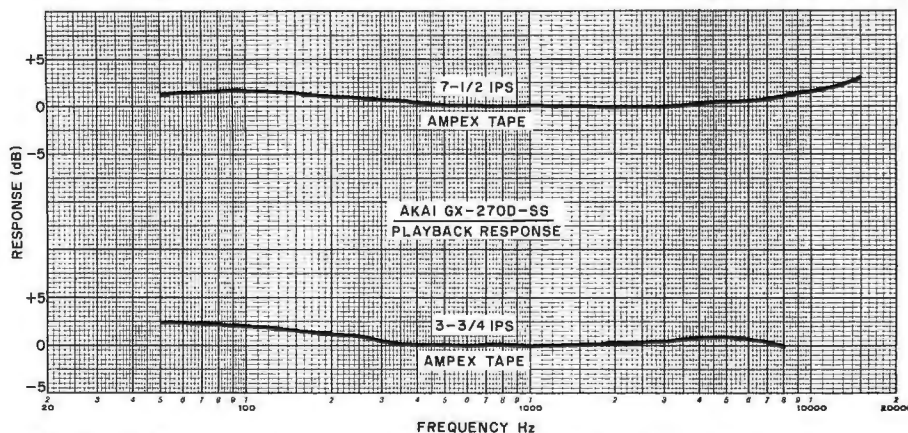

Playback frequency response of the recorder using Ampex test tapes.

record/playback frequency response of the tape deck was measured with several types of tape, using the "wide range" selector position, to determine which best matched the factory settings of the recorder. Although the differences were not large, we found that Memorex Quantum gave the best results; it was subsequently used for the remainder of the tests. Akai SRT-F and Scotch 212 were quite similar to it in performance, while TDK Audua and Maxell UD35-7 had a rising high-end response.

The 7½-ips frequency response was ± 2 dB from 20 to 24,500 Hz at a 20-dB recording level and was virtually the same at 0 dB. There was no sign of tape saturation at 0 dB with any of the tapes used. The 3¾-ips response was within ± 2.5 dB from 30 to 18,500 Hz, and tape saturation rolled off the 0-dB output above 7000 Hz.

The playback frequency response, measured with Ampex test tapes, was within ± 1.5 dB from 50 to 15,000 Hz at 7½ ips. It was ± 1.5 dB from 50 to 7500 Hz at 3¾ ips. Both results represent the frequency limits of the tapes.

A line input of 75 mV or a microphone input of 0.28 mV was necessary for a 0-dB recording level. The playback level from a 0-dB recording was 0.89 volt with

the Memorex tape. (It varies somewhat with the tape used.) The playback distortion at 0 dB at either speed was 0.38% to 0.40%, which is well below the rated value. The reference 3% distortion was reached at a recording input of +10 dB.

The unweighted S/N ratio, referred to the 3% distortion level, was 59 dB at both speeds. With IEC "A" weighting, it was 65.5 dB. With CCIR/ARM weighting, the S/N was 61 dB at 3¾ ips and 64 dB at 7½ ips. The noise level through the microphone inputs was only 3.5 dB higher than through the line inputs.

The flutter of the GX-270-SS was a very low 0.04% at both speeds, which is probably the result of using a direct-drive capstan motor. The PITCH CONTROL had a range of +6.6% to -4.8% at 3¾ ips, and from +5.5% to -4.1% at 7½ ips. In fast forward and rewind, an 1800' (550-m) reel of tape was handled in 100 seconds. The meters responded more slowly than real VU meters, indicating 80% of steady state on 0.3-second tone bursts. The headphone volume was not adjustable and was quite low with 200-ohm phones but fairly good with 8-ohm phones.

User Comment. The operation of the recorder was simple and straightforward, for both conventional operation and for making "Quadra Sync" recordings. The solenoids, which operated with audible "clunks," had a logic system that enabled the buttons to be operated in any sequence without going through STOP. Pressing a normal speed button while the tape was in fast motion (or going in the opposite direction) brought the tape to a smooth, swift stop, after which it paused for a few seconds before resuming play.

On the machine tested, we did not find any effect on the sound when we operated the TAPE SELECTOR buttons. Neither the frequency response, nor the distortion, nor the noise level were affected by this control in any way that we could hear or measure. Also, although the head cover carries the inscription "Auto Reverse," this feature is not mentioned in the instruction manual, nor are there any instructions given on how to install the conductive tape for automatic reversal. A couple of pieces of foil are included with the recorder, with a cryptic statement that they should be installed on either the dull side or the shiny side of the tape. We tried both, and the system operated properly with the foil on either side of the tape. Even if the autoreverse feature is not used, it is still very convenient to be able to play the second pair of



You've got a secret with the amazing Realistic® One Hander™



How's a CB bandit going to take your CB if he doesn't even know you've got one? That's the secret of the One-Hander. Since all controls you need are in the palm-sized handset, you can mount the tiny transceiver case permanently out of sight — in the glovebox, under dash or seat, even in the trunk using a special extension cable. When you leave your vehicle, unplug the handset and lock it up or take it with you. The One-Hander is safer and easier to use while driving — no reaching and fumbling around to make adjustments. Built-in noise blanker and limiter chop out ignition-type noise. Two ceramic filters and push-pull audio circuitry. Improved auto-modulation for FULL talk power, always. With mounting bracket, cables for 12 VDC positive or negative ground. Thieves hate the Realistic One-Hander. But you'll love it. Just 169.95* at your nearby Radio Shack.

1½x5¼x7" case with selector switch for handset speaker, built-in speaker, or optional external speaker.



ALL THE CONTROLS ARE IN THE MIKE

- ✓ Push-to-Talk Switch
- ✓ Speaker and Mike
- ✓ Channel Selector with LED Indicator
- ✓ Volume On/Off Control
- ✓ Variable Squelch
- ✓ 5' Coiled Cord



Trunk-mount your One-Hander: Special 16½-foot cable runs from trunk under carpet to plug-in jack on dash. Everything's hidden! Cable (21-600) just 29.95*.



FREE! New '78 Catalog
Come in for your copy and see what's *really* new in electronics. 164 pages, 100 in full color. 2000 exclusive items.

SOLD ONLY WHERE YOU SEE THIS SIGN:

Radio Shack®

A TANDY COMPANY • FORT WORTH, TEXAS 76107
OVER 5000 LOCATIONS IN NINE COUNTRIES

tracks at the touch of a button, without interchanging the reels.

At 7½ ips, the sound quality of the recorder leaves little to be desired. When we recorded interstation hiss from an FM tuner, we could hear only a minute brightening of the playback in comparison to the incoming signal. This was

consistent with the measured frequency response of the recorder. But at 3¾ ips, the brightness was quite noticeable, even without an A-B comparison.

This deck will appeal most to the serious amateur recordist who wants to try his hand at multi-track-sync recording. It is a versatile machine, equally at home

with recording and playing back 2- and 4-channel tapes or with creating one's own "professional"-style recordings. We were impressed by the manner in which it surpassed every one of its published specifications, usually by a wide margin.

CIRCLE NO. 102 ON FREE INFORMATION CARD

SPEAKERLAB MODEL S7 SPEAKER SYSTEM KIT

Assemble-it-yourself, three-way speaker system employs four drivers.



LABS REPORT

The Model S7 three-way speaker system is one of the six speaker kit models from

Speakerlab. This second from the top-of-the-line kit features an air-suspension system to achieve good bass response in a relatively small enclosure. (Top of the line has a folded-corner-horn design.)

As with all speaker systems kits from Speakerlab, the Model S7's enclosure box is supplied already assembled, requiring only the application of an oil finish (materials supplied) to complete the "wood work." The various elements in the kit—drivers, crossover network, fiberglass insulation, etc.—are mechanically mounted and interconnected.

The Model S7's transducer complement consists of a horn tweeter, horn midrange driver, 12" (30.5-cm) cone-

type woofer, and 10" (25.4-cm) cone-type woofer. Crossover frequencies are nominally at 700 and 5000 Hz, and L pads are provided for adjusting the midrange driver and tweeter balance. Zeners protect the tweeter.

Speakerlab recommends that an amplifier rated at a minimum of 15 to 25 watts/channel be used to drive the Model S7 speaker systems. Maximum guaranteed safe power for the speaker systems is 150 watts rms/channel. Nominal impedance is 4 ohms.

The front and back of the speaker system's walnut-veneer enclosure are made of ¾" (19.1-mm) thick particle board, while the remainder of the box has an additional layer of ¾" plywood added to its thickness. The enclosure measures 29"H × 18"W × 15½"D (73.7 × 45.7 × 38.4 cm). The assembled speaker system weighs 85 lb (38.6 kg). Price is \$279 per speaker system kit.

Kit Assembly. The Speakerlab kit contained everything required to assemble, wire, and finish the speaker system except scissors, stapler, caulking gun, and sandpaper. (The last item is used to gently sand the edges of the box and any rough spots.) A cartridge of silicone rubber adhesive, supplied with the kit, is used instead of screws for driver and subassembly mounting.

The prewired crossover network/input terminal/L pad assembly mounts first over its cutout in the cabinet via a bead of silicone adhesive. Next, the fiberglass wool sheets are cut with scissors to rough sizes and then stapled to all internal walls of the speaker cabinet except the front panel. Once this is done, short lengths of Velcro fastener tape are stapled to the front panel at all four corners.

The front board on which the drivers mount fastens to the cabinet via a thick bead of silicone rubber adhesive between it and the enclosure's particle board liner. A 2" × 2" (5.1 × 5.1 cm) brace is then white glued between the inside rear wall and the rear wall of the front panel between the woofer cutouts to add rigidity and to reduce the possibility of mechanical resonances in the bass range. Finishing nails driven through both walls into the ends of the brace keep the brace from moving while the glue is setting.

Heavy-gauge wires with push-on terminals connect to the drivers from the crossover/L-pad assembly. The drivers then mount in their respective cutouts with the aid of beads of silicone rubber adhesive. No screws are used to hold the drivers in place. The silicone adhe-

(Continued on page 42)

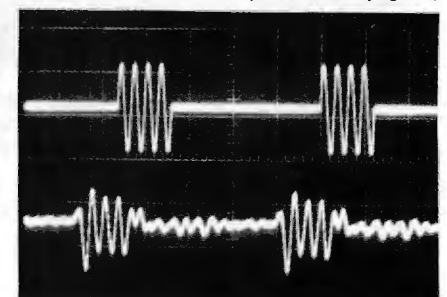
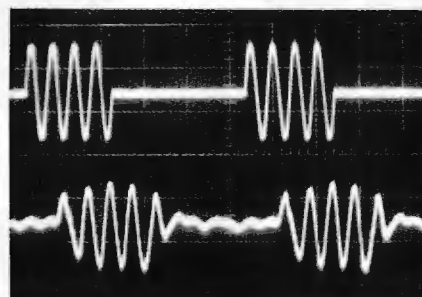
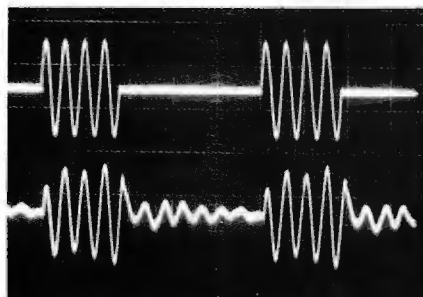

Tone-burst response for (left to right) 100, 1000, and 7000 Hz.

SWTPC announces first dual minifloppy kit under \$1,000



Now SWTPC offers complete best-buy computer system with \$995 dual minifloppy, \$500 video terminal/monitor, \$395 4K computer.



\$995 MF-68 Dual Minifloppy

You need dual drives to get full benefits from a minifloppy. So we waited to offer a floppy until we could give you a dependable dual system at the right price.

The MF-68 is a complete top-quality minifloppy for your SWTPC Computer. The kit has controller, chassis, cover, power supply, cables, assembly instructions, two highly reliable Shugart drives, and a diskette with the Floppy Disk Operating System (FDOS) and disk BASIC. (A floppy is no better than its operating system, and the MF-68 has one of the best available.) An optional \$850 MF-6X kit expands the system to four drives.



\$500 Terminal/Monitor

The CT-64 terminal kit offers these premium features: 64-character lines, upper/lower case letters, switchable control character printing, word highlighting, full cursor control, 110-1200 Baud serial interface, and many others. Separately the CT-64 is \$325, the 12 MHz CT-VM monitor \$175.



\$395 4K 6800 Computer

The SWTPC 6800 comes complete with 4K memory, serial interface, power supply, chassis, famous Motorola MIKBUG® mini-operating system in read-only memory (ROM), and the most complete documentation with any computer kit. Our growing software library includes 4K and 8K BASIC (cassettes \$4.95 and \$9.95; paper tape \$10.00 and \$20.00). Extra memory, \$100/4K or \$250/8K.

Other SWTPC peripherals include \$250 PR-40 Alphanumeric Line Printer (40 characters/line, 5 x 7 dot matrix, 75 line/minute speed, compatible with our 6800 computer and MITS/IMSAI); \$79.50 AC-30 Cassette Interface System (writes/reads Kansas City standard tapes, controls two recorders, usable with other computers); and other peripherals now and to come.

Enclosed is:

- _____ \$1,990 for the full system shown above (MF-68 Minifloppy, CT-64 Terminal with CT-VM Monitor).
- _____ \$995 for the Dual Minifloppy
- _____ \$325 for the CT-64 Terminal
- _____ \$175 for the CT-VM Monitor
- _____ \$395 for the 4K 6800 Computer

- _____ \$250 for the PR-40 Line Printer
- _____ \$79.50 for AC-30 Cassette Interface
- _____ Additional 4K memory boards at \$100
- _____ Additional 8K memory boards at \$250
- _____ Or BAC # _____ Exp. Date _____
- _____ Or MC # _____ Exp. Date _____

Name _____ Address _____
 City _____ State _____ Zip _____

CIRCLE NO. 59 ON FREE INFORMATION CARD



Southwest Technical Products Corp.

219 W. Rhapsody, San Antonio, Texas 78216
London: Southwest Technical Products Co., Ltd.
Tokyo: Southwest Technical Products Corp./Japan

Should your career in electronics go beyond TV repair?

**CREI prepares you at home
for broader and more advanced
opportunities in electronics —
plus offers you special arrangements
for engineering degrees**

There is no doubt television repair can be an interesting and profitable career field. TV repair, however, is only one of the many career areas in the fast growing field of electronics.

As an indication of how career areas compare, the consumer area of electronics (of which TV is a part) makes up less than one-fourth of all electronic equipment manufactured today. Nearly twice as much equipment is manufactured for the communications and industrial fields. Still another area larger than consumer electronics is the government area. That is the uses of electronics in such areas as research and development, the space program, and others.

Just as television is only one part of the consumer field, these other fields of electronics are made up of many career areas. For example, there are computer electronics, microwave and satellite communications, cable television, even the broadcast systems that bring programs to home television sets.

As you may realize, career opportunities in these other areas of electronics are mostly for advanced technical personnel. To qualify for these higher level positions, you need college-level training in electronics. Of course, while it takes extra preparation to qualify for these career areas, the rewards are greater both in the interesting nature of the work and in higher pay. Furthermore, there is a growing demand for personnel in these areas.

Unlike most other home study schools, CREI programs are devoted exclusively to preparing you for careers in advanced electronics. All of CREI programs are college level. And CREI gives you both theory and practical experience in advanced electronics.

Unique Design Lab

A unique feature of CREI training is its Electronic Design Laboratory Program, which trains you to actually design circuits. It also helps you understand the theories of advanced electronics and gives you extensive practical experience in such areas as tests and measurements, breadboarding, prototype construction, circuit operation and behavior, characteristics of electronic components and how to apply integrated circuits.

Career Training at Home

Only CREI offers this unique Lab Program. It is a complete college lab and, we believe, better than you will find in most colleges. The "Lab" is one of the factors that makes CREI training interesting and effective. And the professional equipment in this program becomes yours to keep and use throughout your professional career after you complete the training.

Engineering Degree

CREI offers you special arrangements for earning credit for engineering degrees at certain colleges and universities as part of your home study training program. An important advantage in these arrangements is that you can continue your full time job while "going to college" with CREI. This also means you can apply your CREI training in your work and get practical experience to qualify for career advancement.

Wide Choice of Programs

CREI gives you a choice of specialization in 14 areas of electronics. You can select exactly the area of electronics best for your career field. You can specialize in such areas as computer electronics, communications engineering, microwave, CATV, television (broadcast) engineering and many other areas of modern electronics.

FREE Book

In the brief space here, there isn't room to give you all of the facts about CREI college-level, home study programs in electronics. So we invite you to send for our free catalog (if you are qualified to take a CREI program). The catalog has over 80, fully illustrated pages describing your opportunities in advanced electronics and the details of CREI home study programs.

Qualifications

You may be eligible to take a CREI college-level program in electronics if you are a high school graduate (or the true equivalent) and have previous training or experience in electronics. Program arrangements are available depending upon whether you have extensive or minimum experience in electronics.

Send for this **FREE** Book describing your opportunities and CREI college-level programs in electronics



Mail card or write describing qualifications to

CREI **CAPITOL
RADIO
ENGINEERING
INSTITUTE**

McGraw-Hill Continuing Education Center
3939 Wisconsin Avenue Northwest
Washington, D.C. 20016

Accredited Member National Home Study Council

GI Bill

CREI programs are approved for training of veterans and servicemen under the G.I. Bill.



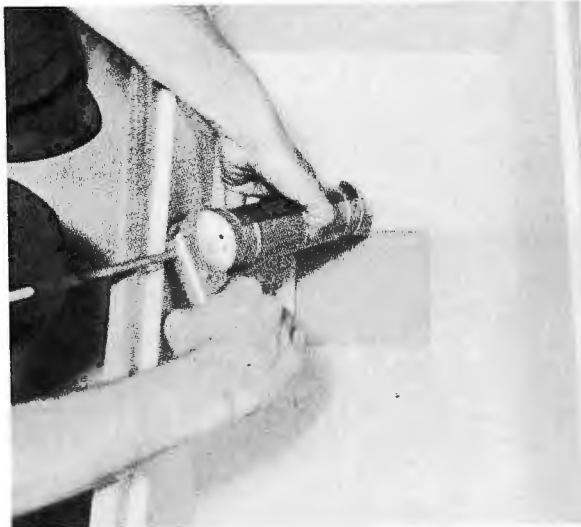

Using a caulking gun, a bead of silicone rubber adhesive is applied around the opening in the enclosure for mounting the electronic assembly.

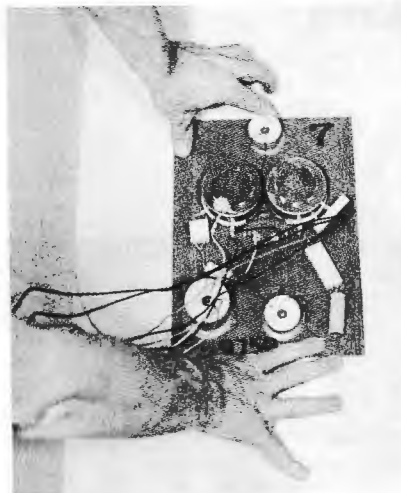

The prewired assembly, holding the crossover network, input terminal, and L pads is pressed into the adhesive.

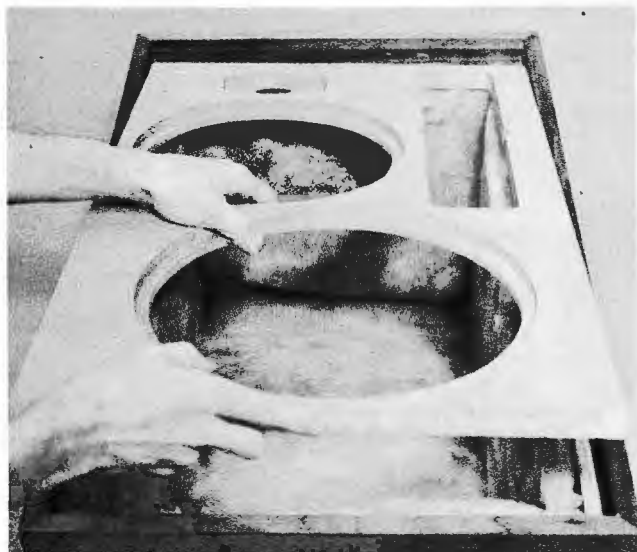

Cabinet is lined with fiberglass and front panel attached, the latter again secured by adhesive.

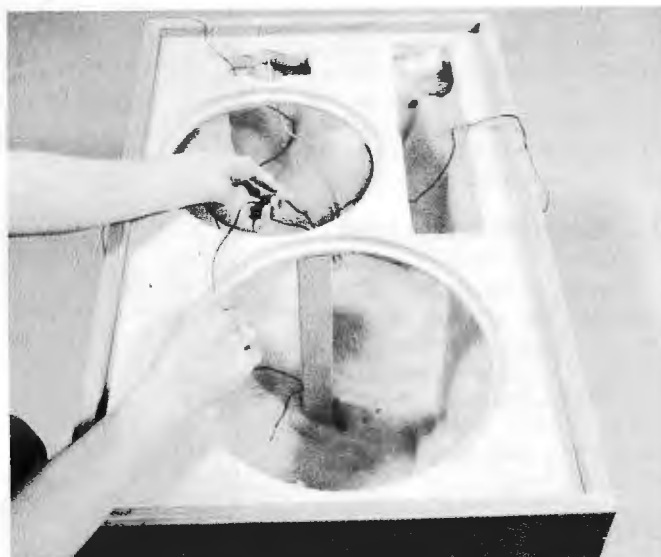

Crossover network leads are pulled through the driver openings. Note supporting wood brace.

sive serves as both mounting and air sealing mediums. The front panel cutout for the horn tweeter is slightly longer in length to permit the driver to slip into place. Consequently, once the tweeter is in place, two small pieces of wood, supplied trimmed to the proper sizes, are glued to the panel to cover up the openings at both ends of the driver horn.

A choice of two different ways of finishing the grille assembly is possible with the materials supplied in the kit. One is a plain flat grille that merely requires the grille cloth to be stretched over and stapled to a ready-made frame. The other is to make the grille assembly three dimensional. To do this, four pieces of wood are glued together to form a frame that is then glued to the ready-made frame. After rounding the edges of the frame, the grille cloth is

stretched over the whole and stapled into place. In either case, Velcro strips are fastened to the frame at the inside rear corners to hold the grille assembly in place.

We allowed four hours for the cemented pieces to set before using the speaker system, which was lying on a floor so that the full weight of the drivers bore down on the silicone adhesive cement/gaskets. We tested the speaker systems beforehand, though, propping them up just enough to permit us to connect cables from our amplifier to them and to permit us to adjust the balance controls.

Once the cements had set and we were satisfied with the operation of the speaker systems, we used No. 150 dry sandpaper to smooth all exterior surfaces of the cabinets. Then we proceeded to pour small amounts of the oil sup-

plied with the kit on one side after another, rubbing it in lightly with No. 400 wet-paper sandpaper. Excess oil was wiped off with a paper towel. Then we allowed the wood to soak up the oil and dry for about two hours. For the finishing touch, we installed the grille assembly, and the system was ready to go to work.

Laboratory Measurements. The middle and high-frequency response of the speaker system was measured in the reverberant field of our room at a distance of 12' to 15' (3.7 to 4.6 m) from the drivers and with the midrange and tweeter level controls set to maximum. To eliminate room interactions at low frequencies, the woofer response was measured separately, with the microphone placed in the plane of the mounting board. Since the system has two dif-

IF YOU'RE WAITING FOR SOLDERLESS BREADBOARDS TO BE FASTER, EASIER, MORE VERSATILE AND LOWER-PRICED...

Incredibly inexpensive. EXPERIMENTOR solderless sockets begin at \$5.50* (\$4.00* for the 40 tie-point quad bus strip). A spool of solder costs more.

Mix and match. Use large and small chips in the same circuit without problems. There are two sizes of EXPERIMENTOR sockets with 3/10th and 6/10th centers.

Full fan-out. A CSC exclusive. The only solderless breadboard sockets with full fan-out capabilities for **micro-processors** and other larger (0.6") DIP's.

Microprocessors and other complex circuits are easy to develop. EXPERIMENTOR quad bus strips give you 4, 8 or 16 buses to simplify your breadboards.

Infinitely flexible. Circuits can go in any direction, up to any size. All EXPERIMENTOR sockets feature positive interlocking connectors that snap together. Horizontally and/or vertically. And un-snap to change a circuit whenever you wish.

Easy Mounting. Use 4-40 screws from the front or 6-32 self-tapping screws from the rear. Insulated backing lets you mount on any surface.

EXPERIMENTOR 350. \$5.50* 46 five-point terminals plus two 20-point bus strips. 0.3" centers; 3/8 x 3 1/2 x 2".

EXPERIMENTOR 650. \$6.25* 46 five-point terminals plus two 20-point bus strips. 0.6" centers; 3/8 x 3 1/2 x 2 1/4".

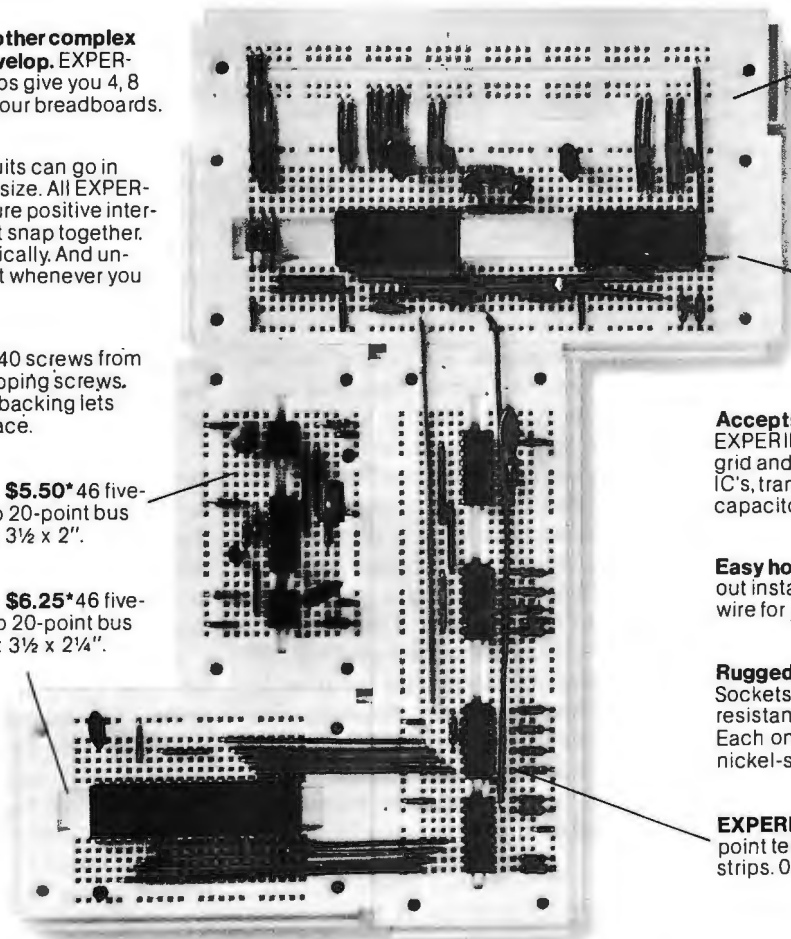

EXPERIMENTOR QUAD BUS STRIP. \$4.00* Four 40-point bus strips. 3/8 x 5 3/4 x 3/4".

Designated tie-points. Simplify translation from breadboard to PC-boards or wiring tables.

EXPERIMENTOR 600. \$10.95* 94 five-point terminals plus two 40-point bus strips. 0.6" centers; 3/8 x 6 x 2 1/4".

Accepts all standard components. EXPERIMENTOR sockets conform to an 0.1" grid and are DIP compatible. Also accept IC's, transistors, diodes, LED's, resistors, capacitors, transformers, pots, etc.

Easy hookup. Components push in and pull out instantly. Use #22-30 solid AWG wire for jumpers.

Rugged, dependable construction. Sockets are constructed from abrasion resistant materials and withstand 100°C. Each one features non-corrosive nickel-silver contacts.

EXPERIMENTOR 300. \$9.95* 94 five-point terminals plus two 40-point bus strips. 0.3" centers; 3/8 x 6 x 2".

WHAT ARE YOU WAITING FOR?

Discover today how solderless breadboarding can save time and money on every circuit you build. Get acquainted with EXPERIMENTOR™ sockets and how they simplify circuit design, assembly and testing. Eliminate the hassles and component damage of soldering. No special hardware or jumper cables required, either. And the price is so low, it's hard to believe.

See your CSC dealer today. Or call 203-624-3103 (East Coast) or 415-421-8872 (West Coast) for the name of your local stocking distributor and a full-line catalog.

CONTINENTAL SPECIALTIES CORPORATION



44 Kendall Street, Box 1942, New Haven, CT 06509
203-624-3103 TWX 710-465-1227
West Coast: 351 California St., San Francisco, CA 94104
415-421-8872 TWX 910-372-7992
MEXICO: ELPRO, S.A., Mexico City 5-23-30-04
CANADA: Len Finkler Ltd., Ontario

SEE US AT WESCON SHOW BOOTH # 1114, 1116 & 1118.

CIRCLE NO. 14 ON FREE INFORMATION CARD



The midfrequency horn driver is prepared for enclosure mounting.

ferently sized woofers, separate measurements were made on each.

The reverberant frequency response was very good. Also, the woofer response was smooth and flat, without a glitch in the upper part of its range. When the two curves were spliced together, the response was within ± 3 dB from 35 to 6000 Hz and rose at higher frequencies. Of course, the shape of the high-frequency curve would vary considerably with different settings of the level controls.

The reasons for using two different woofers are not obvious, since the measured frequency response from each was the same, although the larger cone delivered about 2 dB more output. The output of the woofer reached a maximum between 60 and 80 Hz, falling at a rate of 24 dB/octave below 60 Hz and at about 6 dB/octave above 80 Hz.

The rated impedance of the speaker system is 4 ohms, a fact that was con-

firmed by our tests. It measured 4 ohms at 2 Hz and in the 100-Hz region, with a bass resonance rise to 15 ohms at 50 Hz. The impedance was in the 10-to-12-ohm range at all frequencies above a few hundred hertz.

User Comment. For most of our listening tests, the speaker systems were on tilt stands supplied by Speakerlab. This raised the cabinets about 8" (20.3 cm) above floor level and tilted them back to provide better coverage for the typical seated listener.

In our live-versus-recorded test, the Speakerlab S7 was highly accurate in the upper midrange and at high frequencies. We observed some added warmth in the lower midrange. It did not show up on the response curve, however, and may have been associated with the room's characteristics.

The S7's 4-ohm speaker impedance gives one a sense of higher speaker effi-

ciency as compared to equivalent 8-ohm speakers since it draws more power at a given volume-control setting. Note, however, that one cannot safely use two sets of speaker systems when using 4-ohm ones, even if the remotes are 8-ohm types, as most amplifiers will not be able to handle it. For obtaining maximum power from one set of speakers, however, the 4-ohm types are ideal.

All in all, this is a very fine speaker system. We found it to be equally suited to all kinds of music. Since its balance must be set by ear, the end result naturally depends on the builder's ability to set up both balance controls properly. (Instructions are provided with the kit.)

Assembling this kit was an interesting job. The instruction manual was clearly written and illustrated, and most informative. It took us about two hours to complete each speaker system, excluding waiting time for glue drying. Not having any screws to which to secure the speaker elements eliminated the possibility of damaging the cone by mistakenly moving the driver above it owing to the always surprising heavy weight of the element. But, even if this or any other damage is done, the manufacturer will send a new part, no questions asked. And if you happen to be the unhandiest person around and cannot complete the kit, Speakerlab will finish it for you at no charge (customer pays freight). If you should need help with the kit, there's a toll-free number where you can obtain fast, free assistance.

For those who want to make their own enclosures, speakers and the crossover can be purchased separately for \$191 each channel.

For more information, write Speakerlab, 5500 35th Ave., N.E., Seattle, WA 98105.



Completed system without grille.

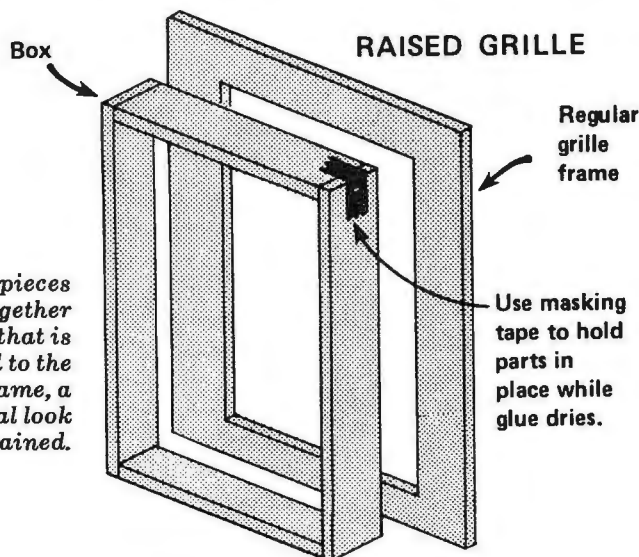

By using four pieces of wood glued together to form a box that is then glued to the regular frame, a three-dimensional look for grille is obtained.

Why you should buy a digital multimeter from the leader in digital multimeters.

If you're shopping for your first multimeter, or moving up to digital from analog, there are a few things you should know.

First, look at more than price. You'll find, for instance, that the new Fluke 8020A DMM offers features you won't find on other DMMs at *any* price. And it's only \$169*

Second, quality pays. Fluke is recognized as the leading maker of multimeters (among other things) with a 30-year heritage of quality, excellence and value that pays off for you in the 8020A.

Third, don't under-buy. You may think that a precision 3½-digit digital multimeter is too much instrument for you right now. But considering our rapidly changing technology, you're going to need digital *yesterday*.

If you're just beginning, go digital.

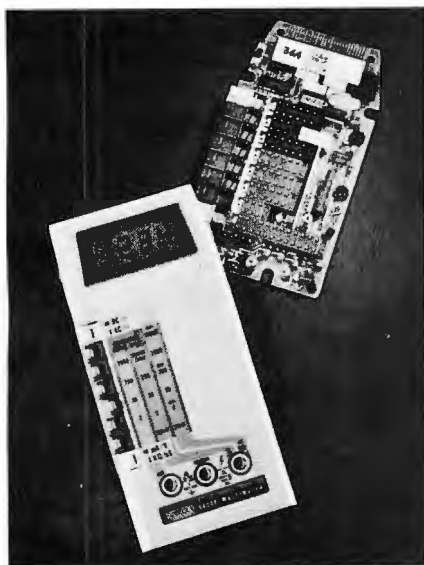

Why not analog? Because the 8020A has 0.25% dc accuracy, and that's *ten*

times better than most analog meters.

Also, the 8020A's digital performance means things like 26 ranges and seven functions. And the tougher your home projects get, the more you need the 8020A's full-range versatility and accuracy. The 8020A has it; analog meters don't.

If you're a pro.

You already know Fluke. And you probably own a benchtop-model multimeter.

Now consider the 8020A: smaller in size, but just as big in capability. Like 2000-count resolution and high-low power ohms. Autozero and autopolarity. And the 8020A is MOV-protected to 6000V against hidden transients, and has overload protection to 300V ac.

Nanosiemens?

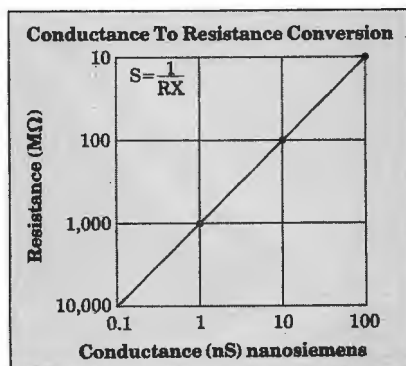

Beginner or pro, you'll find the meter you now have can't measure nanosiemens. So what? With the 8020A *conductance* function, you can measure the equivalent of 10,000 megohms in nanosiemens. Like capacitor, circuit board and insulation leakage. And, you can check transistor gain with a simple, homemade adapter. Only with the 8020A, a 13-oz. heavyweight that goes where you go, with confidence.

What price to pay.



\$169.*

Of course, you can pay more. Or less. In fact, you could pay almost as much for equally compact but more simplistic meters, and get far less versatility. And, the 8020A gives you the 'plus' of custom CMOS LSI chip design, and a minimum number of parts (47 in all). All parts and service available at more than 100 Fluke service centers, worldwide. Guaranteed, for a full year.

Rugged. Reliable. Inexpensive to own and to operate; a simple 9V battery assures continuous use for up to 200 hours.

Where to buy.

Call (800) 426-0361 toll free. Give us your chargecard number and we'll ship one to you the same day. Or, we'll tell you the location of the closest Fluke office or distributor for a personal hands-on feel for the best DMM value going.

*U.S. price only

Fluke 8020A DMM for Home Electronics Experts: \$169



You're looking at the world's best-designed tonearm.

This is a Dual tonearm. It can make a big difference in the way your records sound. And how long they last.

The four-point gyroscopic gimbal is widely acknowledged to be the finest suspension system for a tonearm. It pivots the tonearm precisely where the vertical and horizontal axes intersect. The arm remains perfectly balanced in all planes of movement.

Further, the straight-line tubular design achieves the shortest distance between pivot and stylus. That's basic geometry. Curving the tonearm adds mass, decreases rigidity and makes the arm prone to lateral imbalance.

The vernier counterbalance permits you to balance the tonearm with micrometer-like precision. Tracking force is applied so that the stylus remains perpendicular to the record, even if the chassis is not level.

All this serves to establish and maintain the correct cartridge-to-groove relationship. So the stylus can trace the rapidly changing undulations of the groove walls freely, precisely and with the lowest practical force. In short, flawless tracking.

Despite the advantages of the gimbal-mounted tonearm, you won't find many around. But now, you will find one on every Dual turntable. Even our lowest-priced model, the new, fully automatic 1237.*

It's one more example of Dual's total commitment to engineering excellence.



Dual

For the life of your records

United Audio, 120 So. Columbus Ave., Mt. Vernon, NY 10553

*Less than \$135. Other Duals to \$400. Actual resale prices are determined individually by and at the sole discretion of authorized Dual dealers.

CIRCLE NO. 4 ON FREE INFORMATION CARD

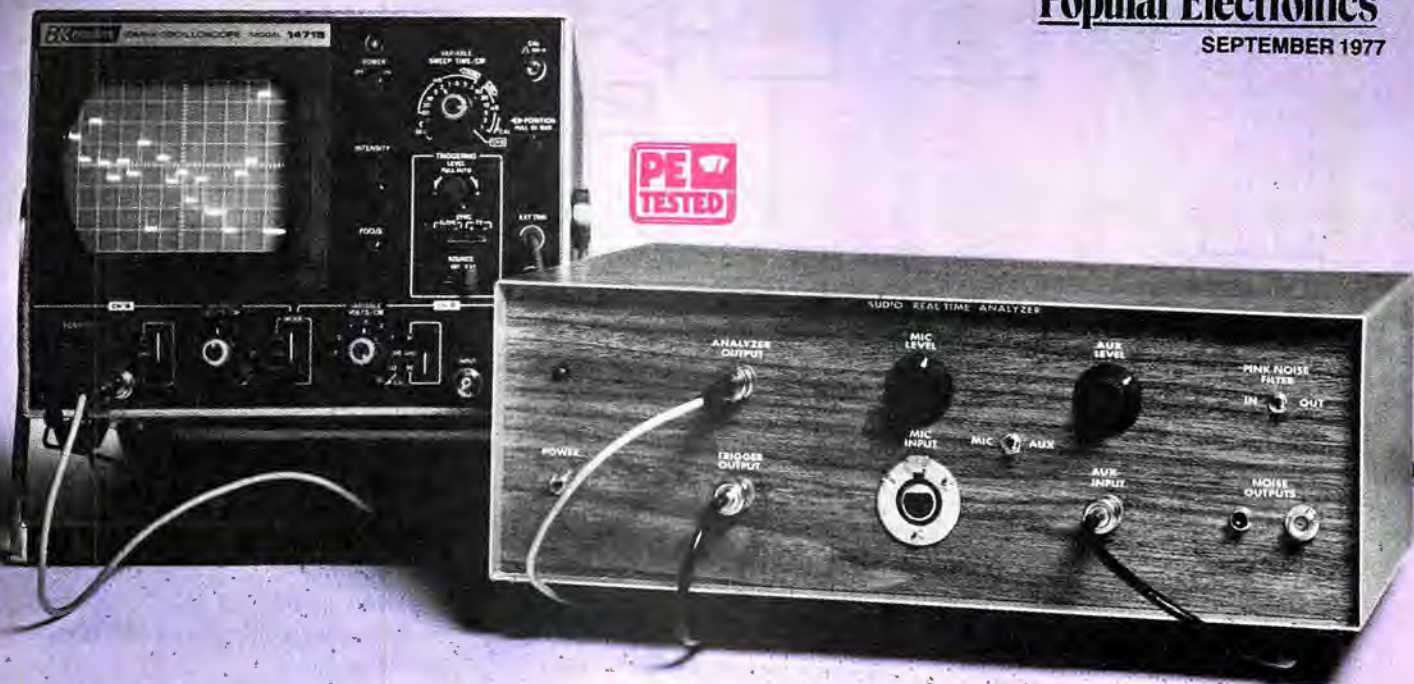

1/2-Octave Real Time Audio Analyzer

BY BOB JONES AND RICHARD MARSH

Used with a mike and oscilloscope, it displays system output to permit accurate matching to room acoustics.

PART 1

IT'S COMMON knowledge that an equalizer can shape a sound system's frequency response. But adjusting multiple equalizer bands for flat audio response in a room is a challenge. This project, an audio Real Time Analyzer, provides a solution to the problem. It generates a graphic representation of the system's output with sufficient detail (20 half-octave bands) to allow quick, accurate matching to room acoustics when used with a calibrated microphone and a dc-coupled oscilloscope.

Furthermore, the RTA can be used to check the frequency response of such components as preamps, power amplifiers, etc. The RTA can also function as a sound pressure meter, as a noise analyzer (energy per frequency band), and as an aid in the design of speaker systems and crossovers.

A block diagram of the RTA is shown in Fig. 1. Input signals are selected by *S1* from MIC or AUX sources. Microphone signals are boosted to line level by a preamp with a gain of 200. A buffer am-

plifier then passes the MIC or AUX signal to twenty half-octave active bandpass filters. Each filter passes only that portion of the input signal within its passband. These filtered ac components are then rectified by diodes (one for each filter) and smoothed by RC combinations. The resulting dc levels, proportional to the amount of energy within each passband, are scanned sequentially by a 24-channel multiplexer. Finally, the multiplexed signal is buffered and presented at the RTA output.

At this point, dc levels can be applied to the vertical amplifier of the oscilloscope. Variations in vertical deflection from one band to the next will linearly reflect differences between dc levels, and hence between the energies contained in the filter passbands. However, in audio work, voltage variations are usually expressed in decibels. A logarithmic converter has therefore been incorporated into the RTA, allowing direct readout of signal levels in dB from the CRT trace. The multiplexing and display func-

tions of the RTA are carried on so quickly that all bands are shown simultaneously or in "real time."

Circuit Details. The input stage of the Analyzer is shown schematically in Fig. 2. A balanced differential amplifier, *IC1*, allows the use of long lines and low-impedance microphones due to its good common mode rejection characteristics. This amplifier has a voltage gain of 200, determined by *R2* and *R4*, and boosts microphone input signals to line level. External frequency compensation for the op amp is provided by *R6* and *C1*. Capacitor *C2* prevents any dc level at the output of *IC1* from reaching microphone level control *R7*.

Signals from either the microphone preamp or a source connected to the AUX input are selected by *S1* and applied to buffer amplifier *IC2*. Frequency compensation is provided by *C3*. The low-impedance output of *IC2* drives the parallel inputs of the half-octave filters.

Each active filter employs one IC (*IC3*

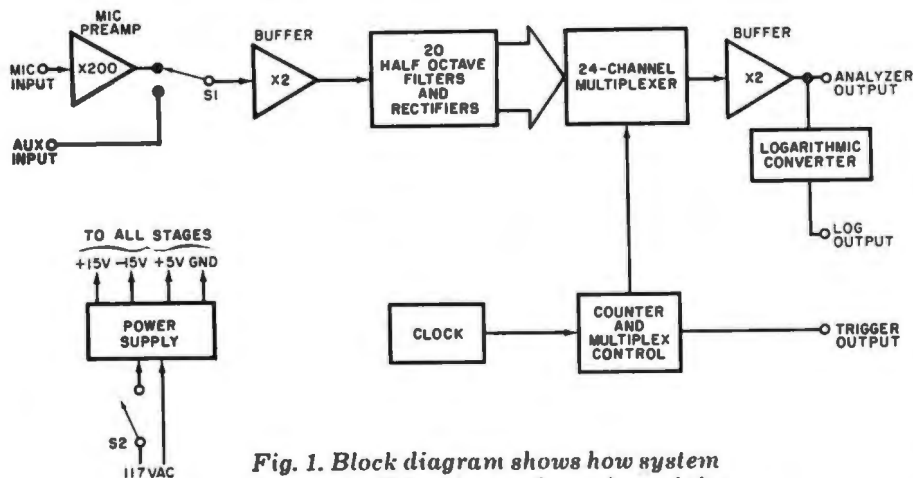

Fig. 1. Block diagram shows how system operates. All bands are shown in real time.

PARTS LIST

C1, C106, C118 through C165—0.01- μ F, 50-V disc ceramic capacitor
 C2, C4—15- μ F, 10-V tantalum capacitor
 C3, C45 through C64—20-pF, 5%, 500-V silver mica capacitor
 C5 through C44—See text and Table I. Close tolerances are essential.
 C65 through C104—1- μ F, 50-V ceramic capacitor
 C105—1.5- μ F, 50-V ceramic capacitor
 C107—500- μ F, 50-V electrolytic capacitor
 C108, C109—50- μ F, 50-V electrolytic capacitor
 C110, C111—10- μ F, 20-V tantalum capacitor
 C112—50- μ F, 10-V tantalum capacitor
 C113 through C117—See Part II
 D1 through D20—1N4148 switching diode
 D21 through D24—1N4003, HEP R0052 or equivalent
 F1—1-ampere slow-blow 3A6 fuse
 IC1—LM725CH operational amplifier
 IC2, IC3 through IC22—LM301AH operational amplifier
 IC23—NE555 timer
 IC24, IC26—SN7490 decade counter
 IC25—SN7404 hex inverter
 IC27—9301 (Fairchild, or equiv.) BCD-to-decimal decoder*
 IC28 through IC30—AM3705D (National Semiconductor, or equiv.) PMOS eight-channel multiplexer**
 IC31—LM741CH operational amplifier
 IC32—MC7815CP or HEP C6114P +15-volt voltage regulator
 IC33—MC7805 or HEP C6110P +5-volt voltage regulator
 IC34—MC7915CP or HEP C6123P -15-volt voltage regulator
 J1—Microphone connector (Cannon XLR-3-13 or equivalent)
 J2 through J4—BNC connector
 LED1—20-mA LED (TIL32 or equivalent)
 The following resistors are 1/8-watt, 1% tolerance, metal-film components.
 R1 through R3—1000 ohms

R4, R5—200,000 ohms
 R35 through R74—See text and Table I.
 The following resistors are 1/4-watt, 5% tolerance carbon components.
 R6—47 ohms
 R9, R12, R14, R95 through R114, R138, —10,000 ohms
 R10, R11—100,000 ohms
 R13—5000 ohms
 R115 through R134—3.3 Megohms
 R135—330 ohms
 R136—560 ohms
 R137—20,000 ohms
 R139—300 ohms
 R7—10,000-ohm, single-turn Cermet potentiometer*
 R8—100,000-ohm, single-turn Cermet potentiometer*
 R15 through R34—50,000-ohm, 20-turn, Helitrim Cermet potentiometer (Beckman 66X or equivalent)*
 R75 through R94—100,000-ohm, single-turn miniature Cermet trimmer potentiometer (Beckman 91W or equivalent)*
 S1—Dpdt miniature toggle switch
 S2—Spst miniature toggle switch
 T1—Triad F91-X universal transformer or equivalent 40-volt center-tapped transformer.*
 Misc.—IC sockets or Molex Soldercons, printed circuit boards, heat sinks, line cord, fuseholder, pc board spacers, suitable enclosure, knobs, coaxial cable, hookup wire, machine and self-tapping hardware, solder, etc.
 Note: The following is available from Southwest Technical Products Corp; 219 W. Rhapsody, San Antonio, TX 78216: set of three etched and drilled pc boards for \$19.00

*Available through distributors such as Allied Radio or Newark Electronics.

**Consult a National Semiconductor local distributor or sales representative.

through IC22) in a Wein-bridge circuit, as shown in Fig. 3. The parallel legs of the filters are formed by R35 through R54 and C5 through C24, and the series legs by R55 through R74 and C25 through C44. The values of these com-

ponents are chosen according to the formula for the center frequency of the filter passband: $f_c = 1/(2\pi RC)$. Note that each RC pair (series and parallel) has the same time constant. Potentiometers R15 through R34 control filter gain and

Q. When properly adjusted, the bandwidth of each filter is exactly one-half octave. With filter center frequencies spaced one-half octave apart, the skirts of the filter response curves will cross over 12 to 18 dB down. This is satisfactory for most audio work.

To achieve the value of Q necessary for narrow bandwidth, the resistors and capacitors in the series and parallel legs of each filter must have close tolerances. Resistors should have tolerances no greater than 1%, and capacitors no greater than 3%. Band-to-band variations in filter gain can be trimmed by LEVEL ADJUST potentiometers R75 through R94. Each filter output is rectified and filtered into a proportional dc voltage by D1 through D20, C85 through C104, R95 through R114 and R115 through R134. A long time constant is employed in the RC filter to average low-frequency components and reduce display bounce.

The digitally controlled multiplex system requires a reference time base or clock. In this project, IC23, a free-running 555 IC timer, generates the necessary clock pulses (Fig. 4). Duty cycle and frequency are determined by R135, R136, and C105. Too high a frequency causes excessive display bounce with a varying input such as random noise. Too low a clock frequency results in display flicker which is hard on the eyes. A clock rate of 2000 Hz was chosen to avoid both undesirable effects.

Clock pulses are applied to IC24, a 7490 decade counter wired to count from 0 to 7, then reset to 0 on the eighth clock pulse. Therefore, a total of eight different output states on three data lines (2⁰, 2¹, 2²) are available. These outputs allow selection of any one of eight FET gates in a 3705 PMOS IC multiplexer. All required decoding circuitry is on the 3705 chip. Of course, twenty channels are needed, not just eight. This is why IC26 and IC27 (7490 and 9301, respectively) are employed. The multiplex circuit is shown in Fig. 5. Each 3705 (three required for 24-channel capacity) has an enable line (E). This allows sequential multiplexer activation.

Decade counter IC26 (7490) is wired to count from 0 to 2, and then reset to 0 on the next pulse from IC25F. For the first seven clock pulses (refer to timing diagram Fig. 6), IC26 has a 0 output. This is decoded by IC27, a 9301 BCD-to-decimal decoder, as a select line one (MPX1 Select) command. Accordingly, multiplexer IC28 is activated. The rectified outputs of the first eight filters are

(continued on page 50)

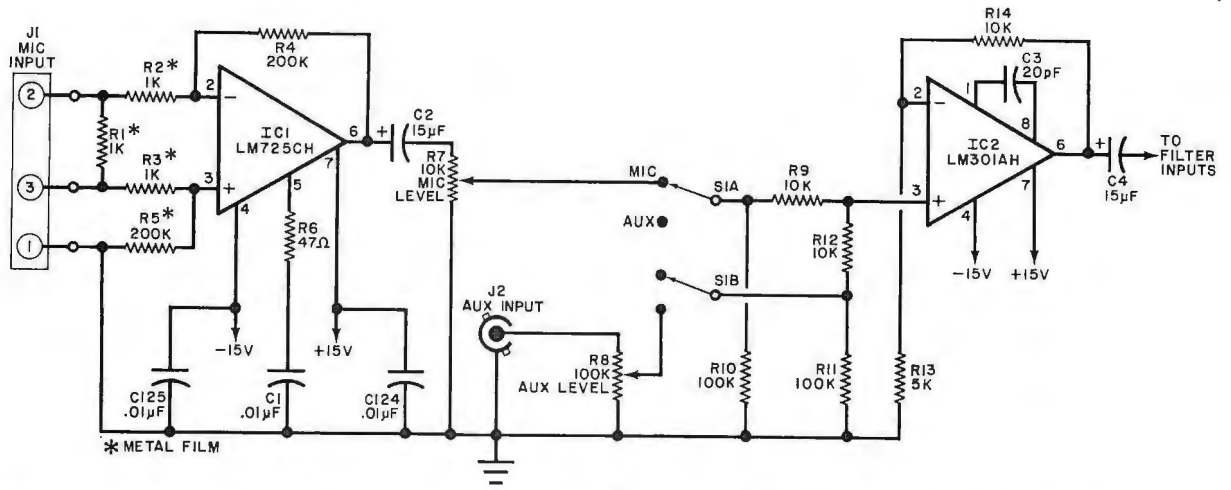

Fig. 2. Input stage includes a balanced differential amplifier, IC1, and buffer, IC2.

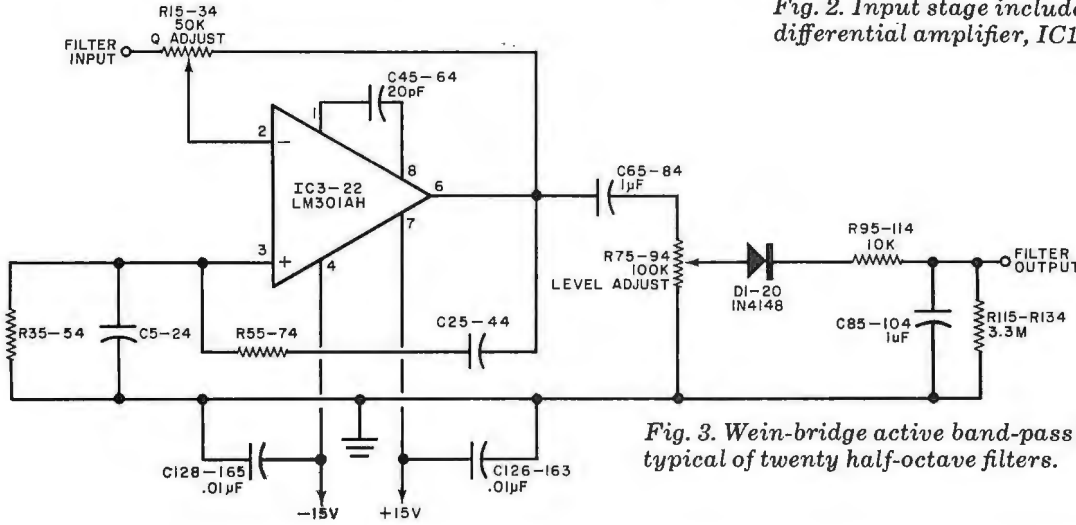

Fig. 3. Wein-bridge active band-pass filter, typical of twenty half-octave filters.

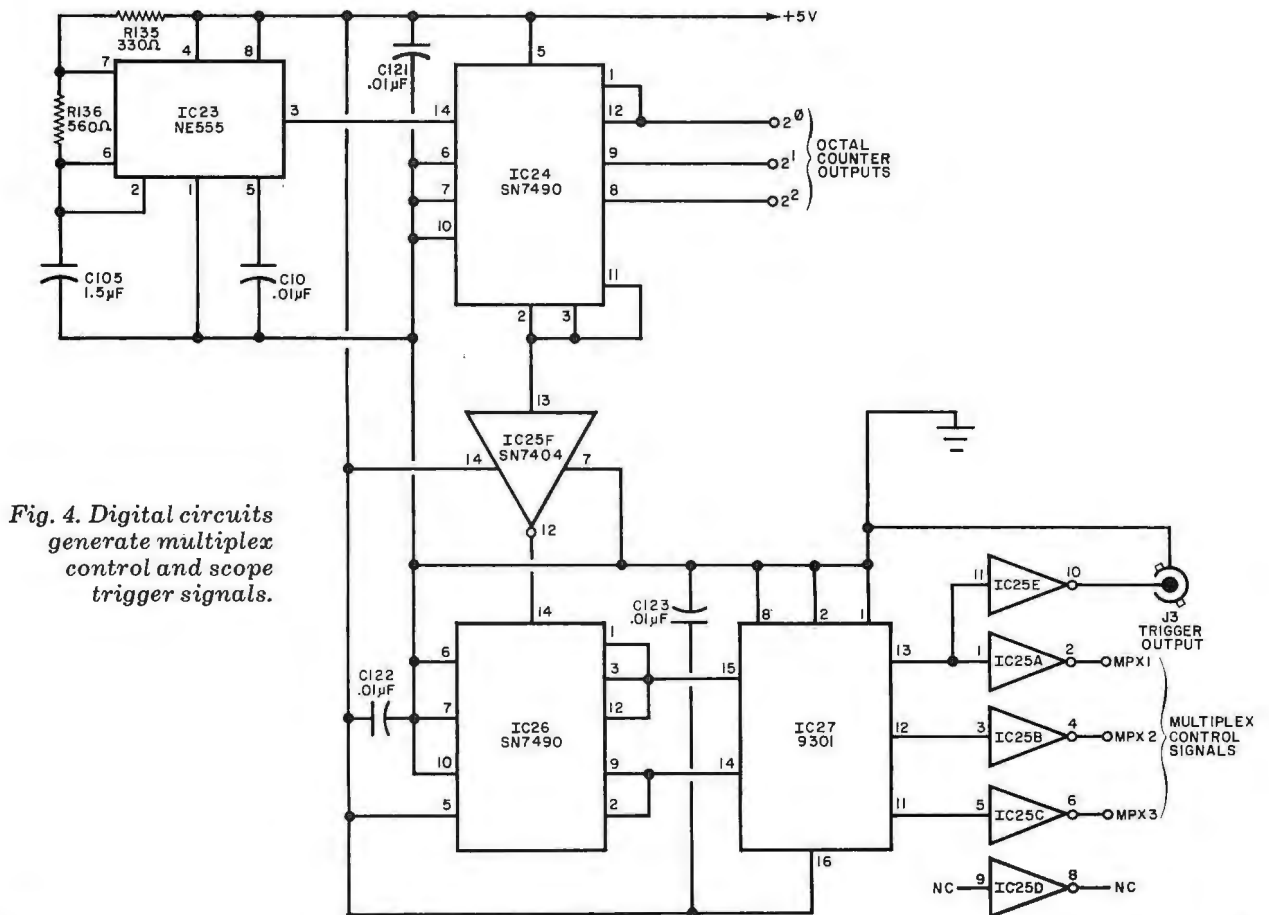

Fig. 4. Digital circuits generate multiplex control and scope trigger signals.

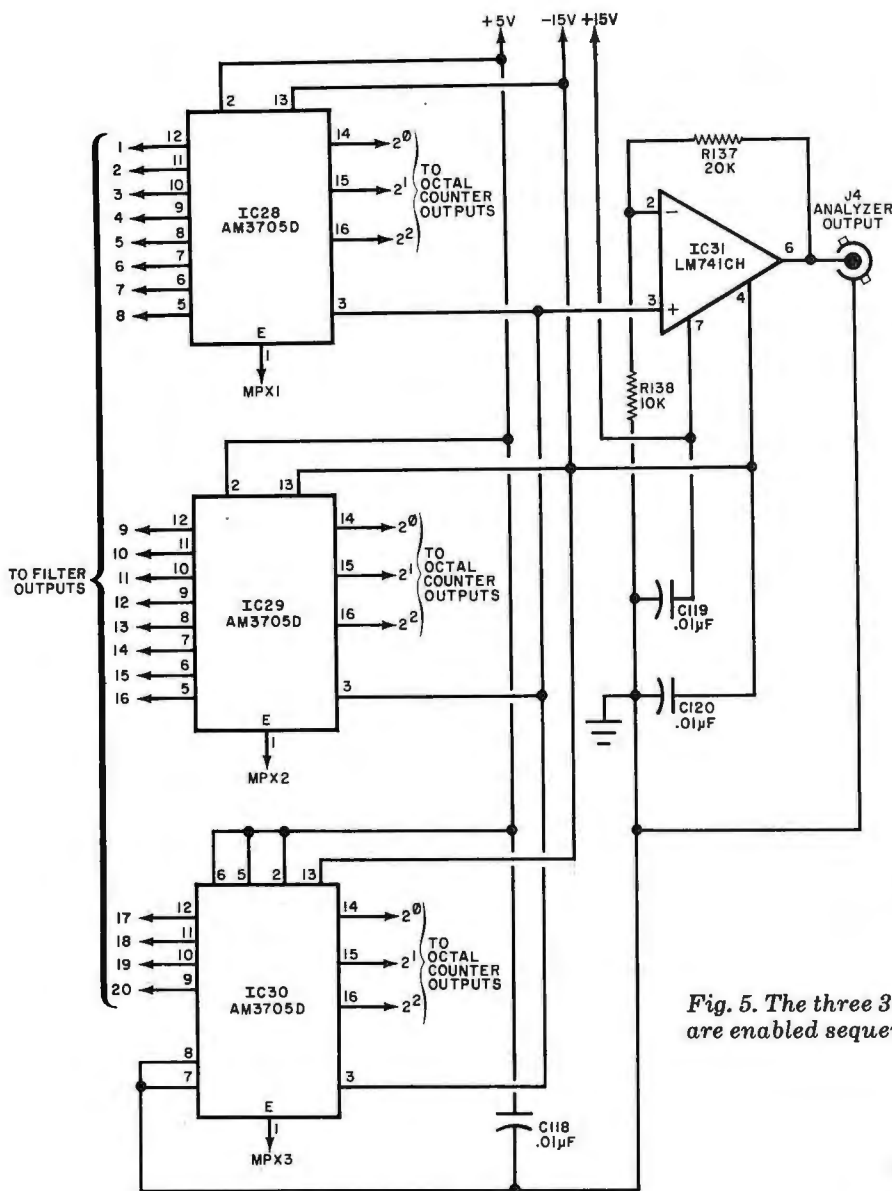
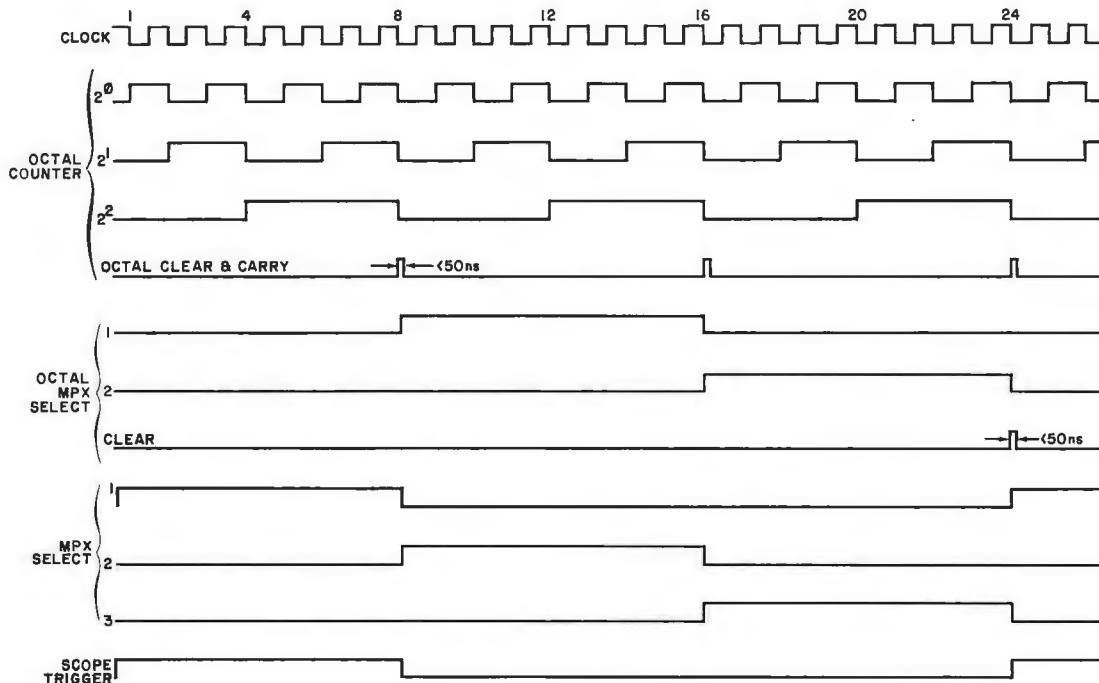

Fig. 5. The three 3705 multiplexer IC's are enabled sequentially.

scanned and sequentially passed to output buffer amplifier IC31, a 741 op amp with a voltage gain of two. On the eighth clock pulse, IC24 will revert to a 0 output, IC26 will increment to 1, causing MPX2 Select to go high and activating IC29. Thus, the outputs of filters 9 through 16 are scanned and passed to IC31. On the sixteenth clock pulse, IC24 causes IC26 to increment to 2, and IC27 issues an MPX3 Select command which enables IC30. Accordingly, the rectified outputs of filters 17 through 20 are scanned and passed to the buffer. At clock pulses 21 and 22, a ground (0 volt) is sent to the scope for base line reference. At clock pulses 23 and 24, IC30 sends +5 volts (boosted by IC31 to 10 volts) to the scope for maximum level reference. (Input signal levels should be adjusted to fall within these extremes.) At clock pulse 24, IC24 and IC26 reset themselves to zero, MPX1 Select again goes high and the process is repeated. Also, a positive-going transition at clock pulse 24 is used for scope triggering.

The power supply for the Analyzer is shown schematically in Fig. 7. Transformer T1 (40 V CT) and diodes D21 through D24 form a bridge rectifier. Ca-

Fig. 6. The timing diagram below shows the clock waveform (top) and the events that occur at various clock pulses.



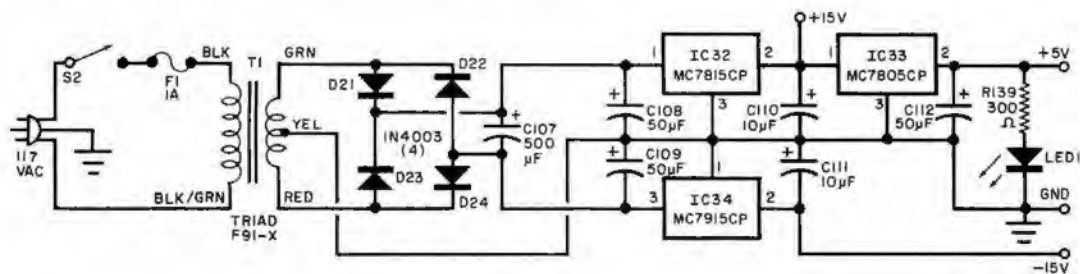

Fig. 7. Schematic of power supply circuit shows bridge rectifier and voltage regulators.

TABLE I—FILTER VALUES

Filter	Center Frequency f_c (Hz)	Resistors (ohms)	Capacitors (μ F)
1	22.4	R35, R55—68, 100	C5, C25—0.1
2	31.5	R36, R35—75,000	C6, C26—0.068
3	45	R37, R57—51,100	C7, C27—0.068
4	63	R38, R58—38,300	C9, C29—0.047
5	90	R39, R59—38,300	C9, C29—0.047
6	125	R40, R60—26,100	C10, C30—0.047
7	180	R41, R61—26,100	C11, C31—0.033
8	250	R42, R62—28,700	C12, C32—0.022
9	355	R43, R63—46,400	C13, C33—0.01
10	500	R44, R64—31,600	C14, C34—0.01
11	710	R45, R65—31,600	C15, C35—0.0068
12	1000	R46, R66—23,700	C16, C36—0.0068
13	1400	R47, R67—23,700	C17, C37—0.0047
14	2000	R48, R68—23,700	C18, C38—0.0033
15	2800	R49, R69—26,100	C19, C39—0.0022
16	4000	R50, R70—38,300	C20, C40—0.001
17	5600	R51, R71—28,700	C21, C41—0.001
18	8000	R52, R72—42,200	C22, C42—470pF
19	11200	R53, R73—31,600	C23, C43—470pF
20	16000	R54, R74—28,700	C24, C44—360pF

capacitors C107, C108, and C109 provide input ripple filtering to IC voltage regulators IC32, IC33, and IC34. Capacitors C110, C111, and C112 provide output filtering. Resistor R139 limits current to LED1, the front panel power indicator.

Construction. The RTA is most easily assembled on three printed circuit boards (four if the optional log converter is desired). Etching and drilling and component placement guides for the Digital and Power Supply Board, Filter Board 1, and Filter Board 2 are shown in Figs. 8, 9, and 10, respectively. (See Table I for RC values for each filter.)

Mount all components on the pc boards using the minimum heat and solder required for good connections. Pay close attention to the polarity and basing of electrolytic (aluminum and tantalum) capacitors, diodes, transistors, and integrated circuits. The use of IC sockets or

Fig. 8A. Parts placement guide for digital and power supply board. See next page for etching and drilling.

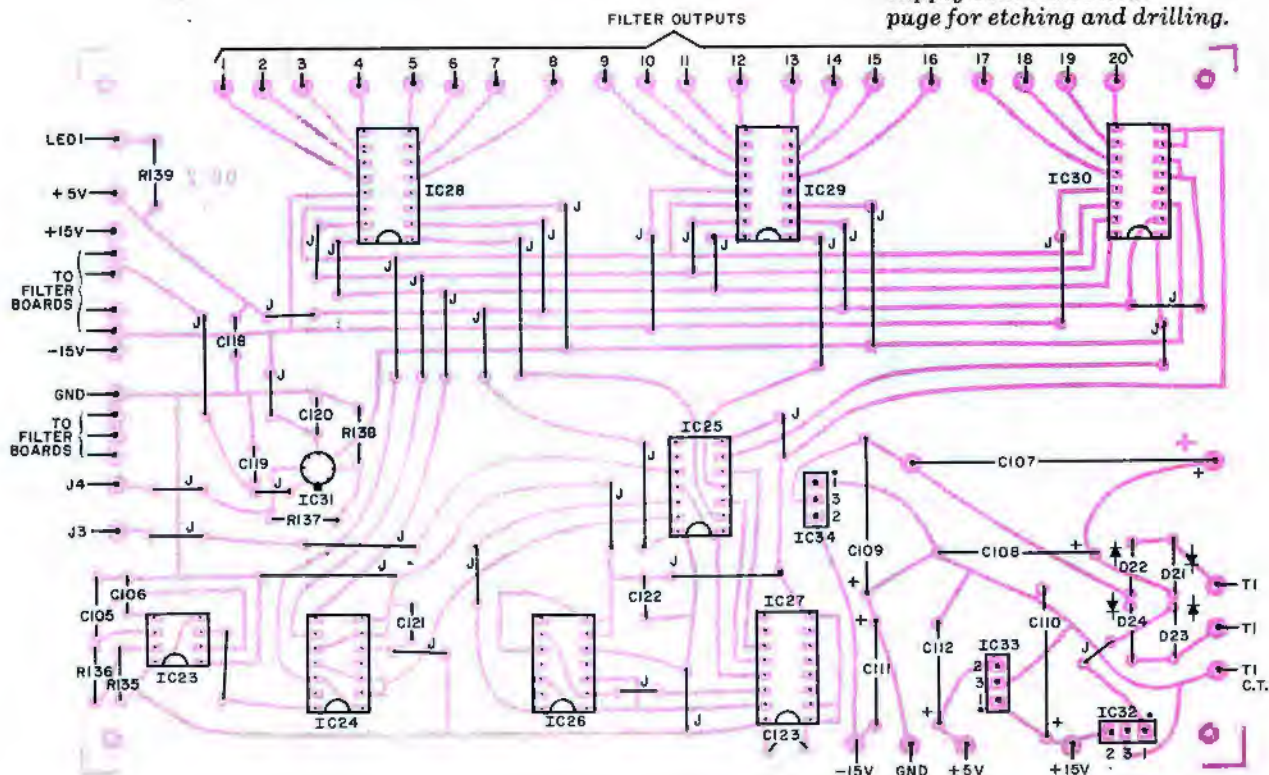

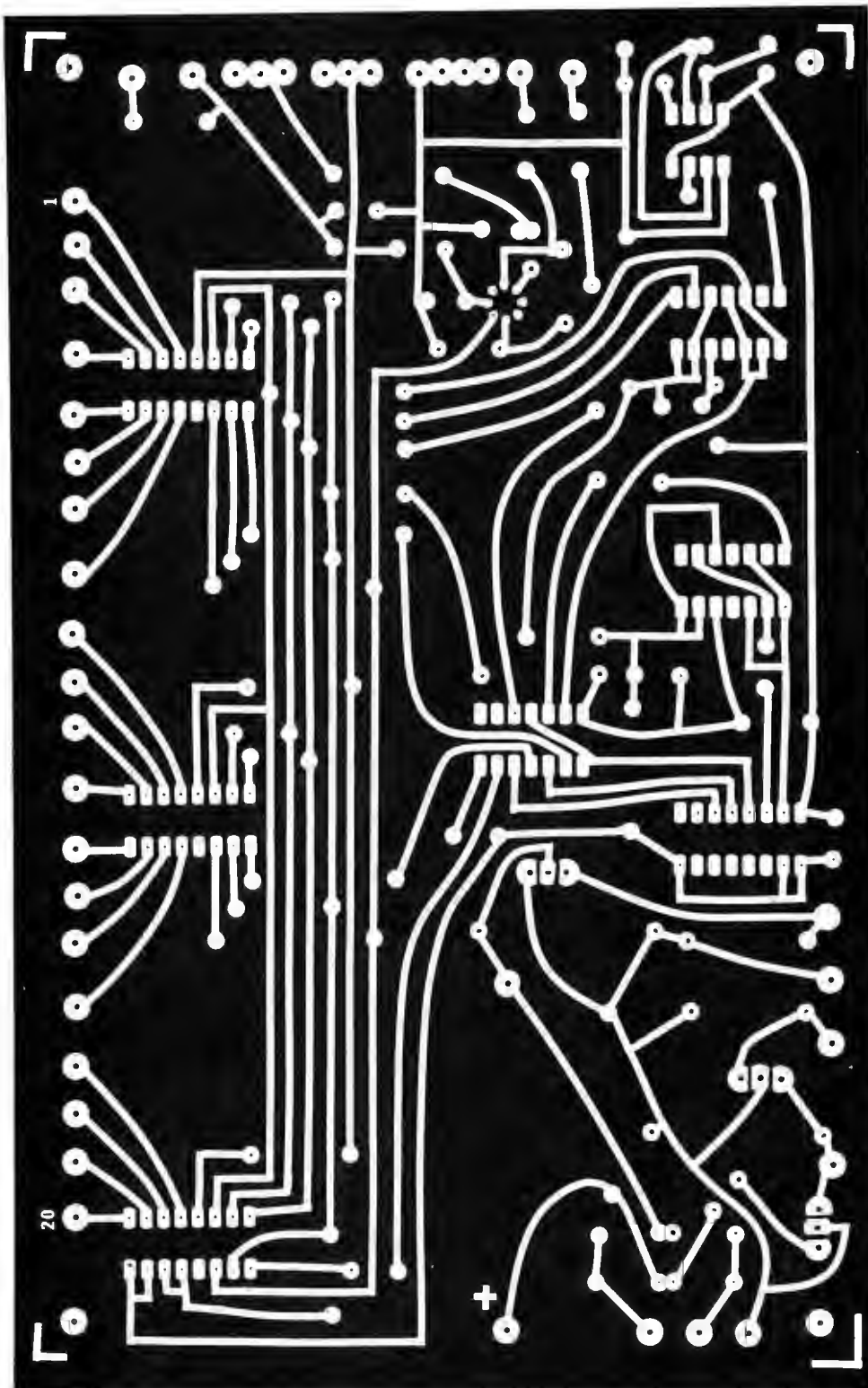

Fig. 8B. Etching and drilling guide for digital and power supply board.

Molex Soldercons for all IC's is recommended. All signal lines to and from the boards should be shielded (small-diameter coax is ideal). The power transformer should be mounted as far away from the boards as possible to minimize hum.

This transformer (T1) is a "universal" transformer, and not all of its color-coded leads are used. Cut short any unused

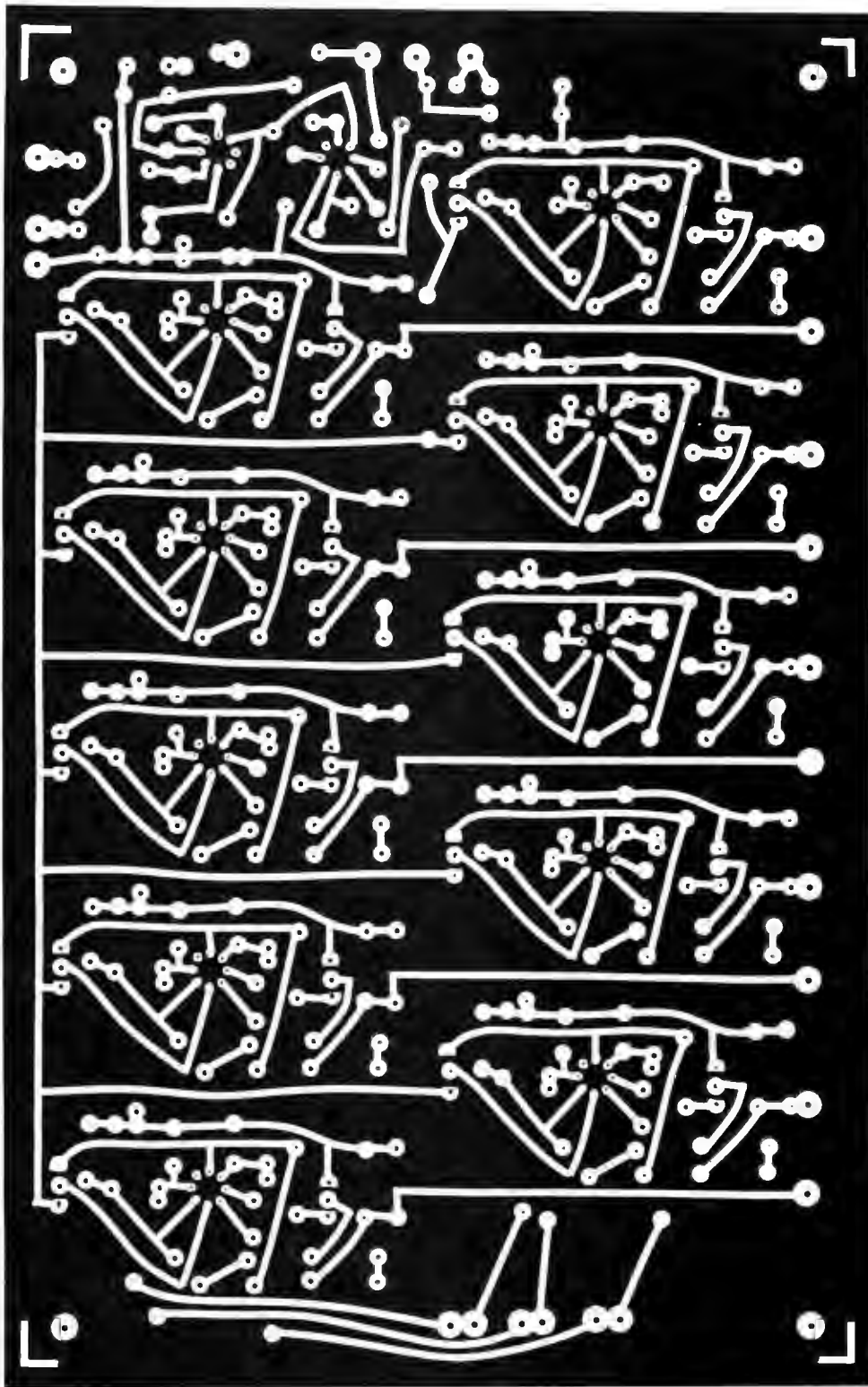

Fig. 9A. Use this pc board for Figs. 9B and 10 on next page.

leads and cover the ends with heat-shrink tubing. Also, be sure to use heat sinks on the voltage-regulator IC's.

In the authors' prototype, the pc boards (except the log converter) were stacked to conserve space. If you want to stack the boards, be sure to leave sufficient clearance for easy access to the LEVEL ADJUST and Q ADJUST potentiom-

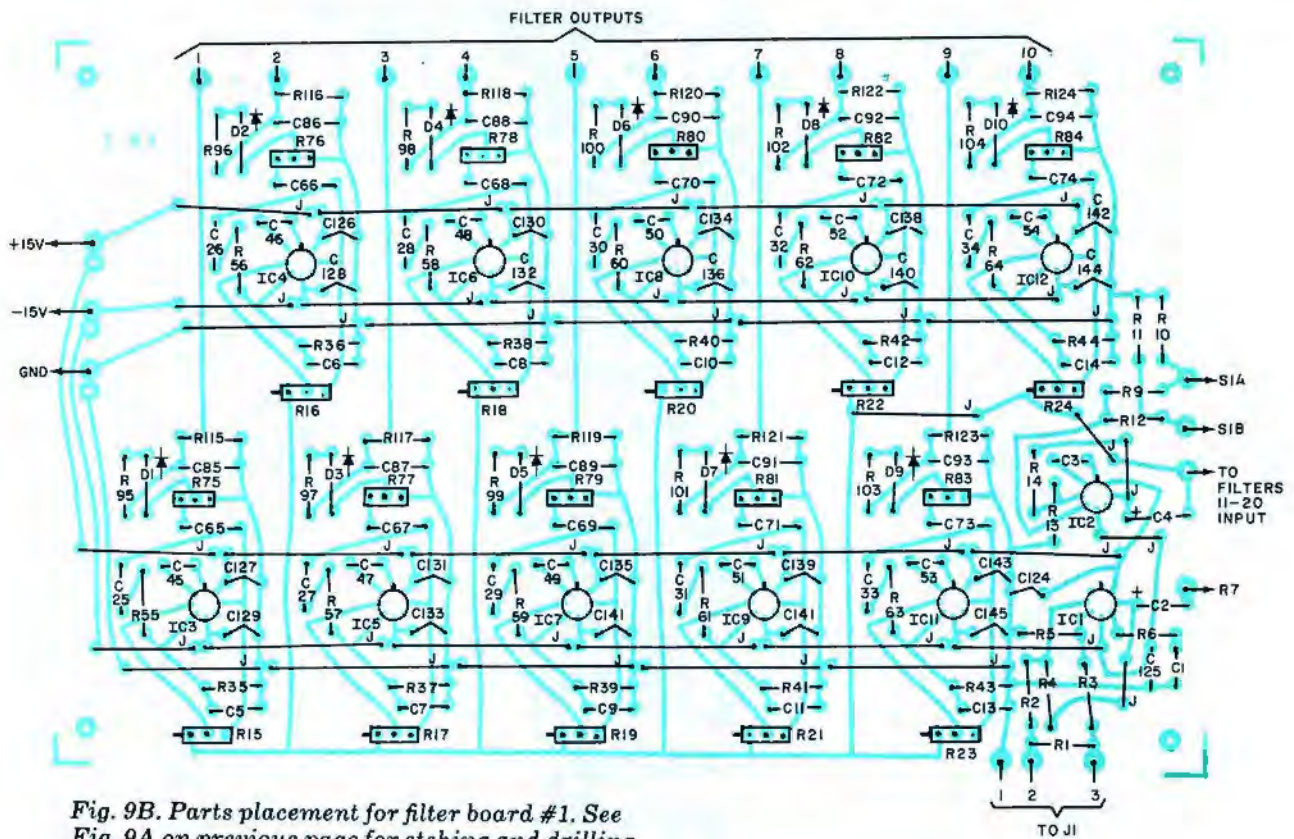

Fig. 9B. Parts placement for filter board #1. See Fig. 9A on previous page for etching and drilling.

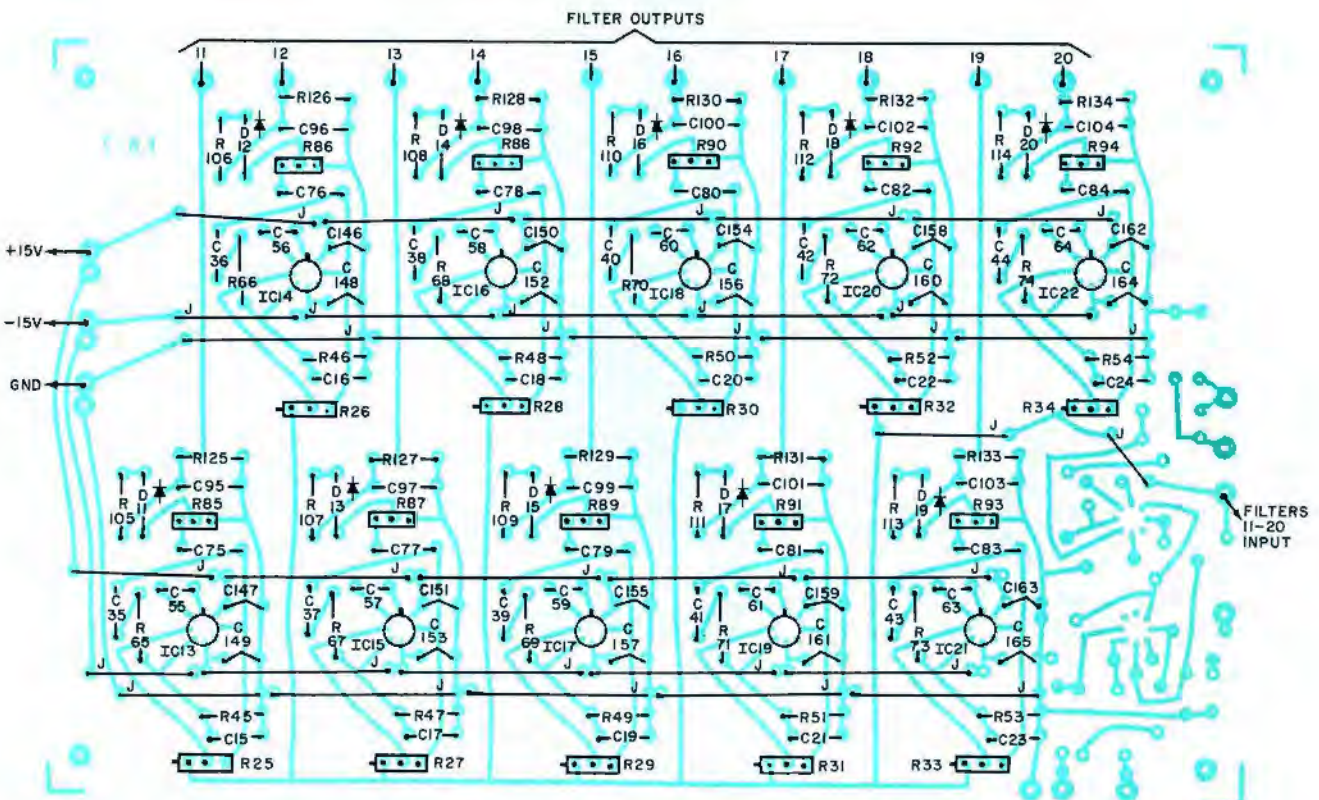

Fig. 10. Parts placement for filter board #2. See Fig. 9A for etching and drilling.

eters. These controls should be mounted on the filter boards so that all adjustment screws point toward power supply pads and away from input pads.

The prototype was enclosed in a 15" x

10" x 5" (38.1 x 25.4 x 12.7 cm) metal cabinet. Switches *S1* and *S2*, LEVEL controls *R7* and *R8*, jacks *J1* through *J5*, and *LED1* were mounted on the front panel. The fuseholder and line cord

strain relief were mounted on the rear.

Part II of this article will describe an optional log converter for direct readout of the scope trace in dB. Calibration and RTA use will also be covered. ◇

BUILD A TRANSFORMERLESS DC-TO-DC VOLTAGE DOUBLER

High-efficiency, high-current solid-state circuit doubles the input dc level.

BY MARLOWE J. BUCHANAN

FOR MANY years, the only reasonable nonmechanical means of generating high dc potentials from low voltages in the medium-to-high-power range has been the oscillator-driven transformer. This type of converter has two major drawbacks—the average experimenter may not have the knowledge or the materials to design and build his own transformer/converters, and the power consumption is relatively high, making the converters inefficient at currents much below their ratings.

The capacitive voltage doubler described here is superior to normal converters in many applications. For example, it can be used to extend the range of a low-voltage power supply or to run a

medium-power audio system in a vehicle. Capable of very high efficiencies, the converter can easily be adapted to the voltage and power needed.

Circuit Operation. Basically, the circuit shown in Fig. 1 acts as a set of high-speed electronic switches that alternately charge $C3$ and $C4$ to the supply voltage and then connect the capacitors in series with the supply and load. The output load in effect "sees" the sum of the voltages across $C3$ and $C4$ and the supply voltage. Since $C3$ and $C4$ are driven 180° out-of-phase, this is a true full-wave voltage doubler.

Transistors $Q7$ and $Q8$ and their associated components form a multivibra-

tor that has an operating frequency of roughly 6000 Hz with a 12-volt dc input supply. This oscillator produces two square waves that are 180° out-of-phase with each other and are used to drive $Q5$, $Q6$, $Q9$, and $Q10$. Resistors $R1$ through $R4$ are selected to limit base current to 3 mA. Drive transistor pairs $Q5/Q9$ and $Q6/Q10$ produce equal and opposite square waves that have extremely fast rise and fall times and are capable of sinking or sourcing a minimum of 100 mA to the output transistor pairs ($Q1/Q2$ and $Q3/Q4$).

When $Q7$ conducts, $Q2$, $Q3$, $Q5$, and $Q10$ are driven into saturation. Capacitor $C3$ charges through $Q2$ and $D3$, while $C4$ discharges through $Q3$, $D2$ and

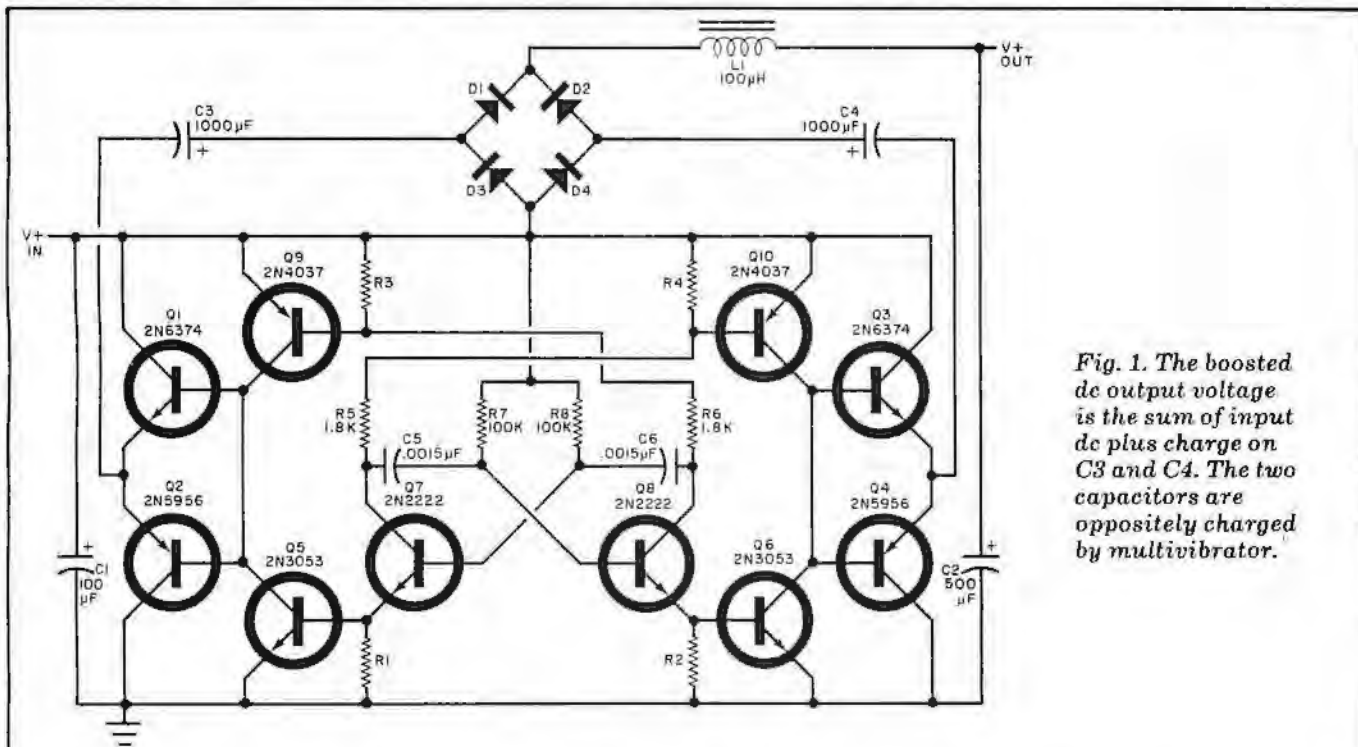

Fig. 1. The boosted dc output voltage is the sum of input dc plus charge on $C3$ and $C4$. The two capacitors are oppositely charged by multivibrator.

PARTS LIST

$C1$ —100- μ F, 25-V electrolytic capacitor
 $C2$ —500- μ F, 50-V electrolytic capacitor
 $C3$, $C4$ —1000- μ F, 50-V electrolytic capacitor
 $C5$, $C6$ —0.0015- μ F, 50-V capacitor
 $D1$ through $D4$ —50-V, 6-A rectifier diode (or bridge)
 $L1$ —100- μ H, 4-A, 0.1-ohm dc resistance (or less) choke

$Q1$, $Q3$ —2N6374 or similar transistor
 $Q2$, $Q4$ —2N5956 or similar transistor
 $Q5$, $Q6$ —2N3053 or similar transistor
 $Q7$, $Q8$ —2N2222 or similar transistor
 $Q9$, $Q10$ —2N4037 or similar transistor
 Following resistors are $1/4$ or $1/2$ watt, 10%:
 $R1$ through $R4$ —For input of 6 volts, omit; for

9 V, use 1000 ohms; for 12 V, use 330 ohms; for 15 V, use 180 ohms; for 18 V, use 120 ohms; for 21 V, use 100 ohms; for 24 V, use 82 ohms.
 $R5$, $R6$ —1800 ohms
 $R7$, $R8$ —100,000 ohms
 Misc.—10-watt heat sink, suitable enclosure, heavy-gauge wire, mounting hardware, etc.

Empire's Blueprint For Better Listening

No matter what system you own, a new Empire phono cartridge is certain to improve its performance.

The advantages of Empire are threefold.

One, your records will last longer. Unlike other magnetic cartridges, Empire's moving iron design allows our diamond stylus to float free of its magnets and coils. This imposes much less weight on the record surface and insures longer record life.

Two, you get better separation. The small, hollow iron armature we use allows for a tighter fit in its positioning among the poles. So, even the most minute movement is accurately reproduced to give you the space and depth of the original recording.

Three, Empire uses 4 poles, 4 coils, and 3 magnets (more than any other cartridge) for better balance and hum rejection.

The end result is great listening. Audition one for yourself or write for our free brochure, "How To Get The Most Out Of Your Records." After you compare our performance specifications we think you'll agree that, for the money, you can't do better than Empire.



EMPIRE

Already your system sounds better.

Empire Scientific Corp.
Garden City, New York 11530

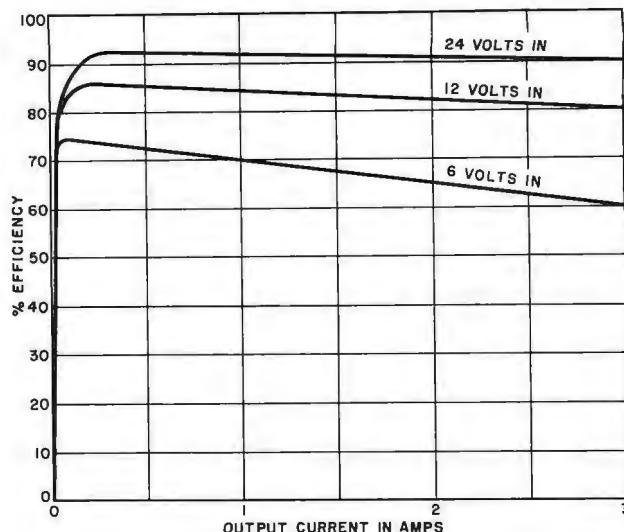

Fig. 2. With 12-volt power source, the efficiency remains above 80% even with full load. The higher the input voltage, the higher the efficiency.

the output load. When $Q8$ conducts, the process reverses itself, with $C3$ discharging through the output load, $Q1$, and $D1$, while $C4$ charges through $Q4$ and $D4$. Capacitor $C1$ helps prevent high-frequency pulses from entering the supply, while $L1$ and $C2$ filter the output.

Construction. Since circuit operation is not critical, any convenient means of construction can be used to build the converter. However, for maximum efficiency and minimum ripple, the following should be observed:

Keep all leads, especially those to the output devices, as short as possible. Even the minor inductance of long wires can cause ripple in the output at the high switching frequency used in this voltage converter.

Use 12- or 14-gauge wire for power lines and making connections to output transistors $Q1/Q2$ and $Q3/Q4$. If you elect to assemble the circuit on a printed circuit board, use at least $\frac{1}{4}$ " (6.4-mm) wide copper traces to interconnect the output devices. These measures will eliminate resistive voltage losses.

Connect $C1$ as close as possible to the emitter leads of $Q5/Q6$ and $Q9/Q10$ to minimize ripple feedback into the voltage source.

No heat sinking is required for outputs up to 1 ampere. At higher currents, $Q1$ to $Q4$ must be on a heat sink that has a thermal resistance of $5^\circ\text{C}/\text{watt}$.

Use. The major loss of efficiency in a capacitive voltage doubler is the inherent voltage drop across the diodes and output transistors. Hence, it is not possible to exactly double the supply voltage, the difference being 1.4 volts with no load to 4.8 volts with a 3-ampere load. Since these losses are a fixed function of the output current, overall efficiency

will increase dramatically with higher operating potentials, as shown in Fig. 2. Efficiencies in excess of 98% at several hundred watts can be achieved by a capacitive voltage doubler adapted for 100 volts input. These doublers also have very low ripple, typically less than 200 mV at a 3-ampere output.

The other loss of efficiency is the power consumed by the multivibrator and drive transistors. This is generally less than 150 mW at a 12-volt dc input, which accounts for the circuit's ability to achieve high efficiencies over 98% of its operating range. This sharply contrasts with the much lower efficiencies obtainable with transformer-based converters.

If the circuit shown in Fig. 1 does not satisfy your needs, there are a number of adaptations you may wish to try. For example, higher currents or potentials can be handled by substituting appropriately rated devices and slightly altering the multivibrator. Higher efficiencies can be obtained by substituting germanium power transistors for $Q1$ through $Q4$ and replacing the rectifiers with four suitable germanium power rectifiers (transistors with the base tied to the collector or emitter). For currents less than 100 mA, $Q1$ through $Q4$ can be omitted; $C2$, $C3$, $C4$ need be rated at only 50 μF ; and the rectifier diodes ($D1$ through $D4$) can be rated at 1 ampere each.

A voltage tripler can be made by adding two 1000- μF capacitors and another bridge rectifier between ground and the common emitters of the output transistors. However, triplers work at lower efficiencies and with considerably reduced output current capability.

It is possible to use the output of one doubler as the input voltage source for another doubler. Two doublers connected in this manner provide about 36 volts output from a 12-volt battery. \diamond

Special Focus on AUDIO

- THE BASICS OF BUYING HI-FI COMPONENTS
- DYNAMIC NOISE REDUCTION SYSTEMS AND EXPANDERS
- MATCHING TAPES TO RECORDERS
- IC MULTIPLEX DECODER IMPROVES STEREO FM PERFORMANCE
- QUIZ OF AUDIO BASICS

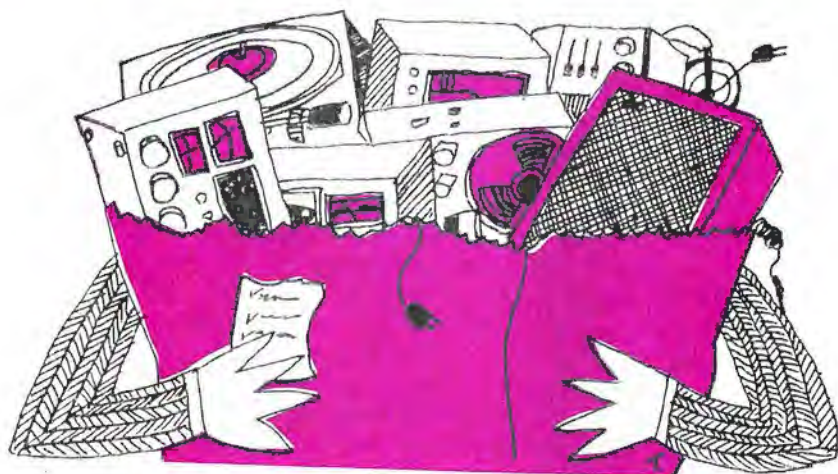

The Basics of Buying HI-FI COMPONENTS

YOU can run down to your neighborhood appliance store, hand the clerk around \$99.95, and come away with a "home music system" that will deliver music received via AM or FM broadcasting and probably play records as well. Or, you can go to your favorite furniture shop and spend a few hundred dollars or more for a console cabinet containing unspecified electronic elements that will do the same thing. Finally, you can shop for individual audio components, spending anywhere from a few hundred dollars to many thousands of dollars and, again, end up with a home music system that reproduces radio broadcasts, records, and even tape recordings. These three divergent approaches to home music reproduction

have some things in common—but they are also poles apart in terms of the kind of sound you will hear.

Crammed inside the \$99.95 compact system and the one-piece console are circuits which pick up radio signals and translate them back to audio signals, circuits which amplify the minute signals picked up by a self-contained record player with its tonearm and cartridge, and even a pair of loudspeakers which translate all these signals back to audible sound. Audio electronics can be further broken down into the "tuner" or radio section, the "preamplifier" or control section, and the "power-amplifier" section which activates the loudspeakers. Even a tiny portable transistorized radio contains all these elements, but you

would hardly classify the sound you hear from such a portable as "high fidelity."

In order for a loudspeaker (or, a pair of loudspeakers in the case of stereo or four loudspeakers for quadraphonic sound) to reproduce music, its cone or diaphragm must vibrate, for sound is nothing more than rapid compressions or expansions of the air around us. When the air vibrates rapidly, we hear a high-pitched tone. Slower vibrations of air impinge upon our hearing mechanism to create the hearing sensation of a low-pitched note—or one of low frequency. But, whenever a pair of loudspeakers is mounted in the same cabinet as the delicate record-playing tonearm and pickup, the fairly violent vibrations of that speaker (needed to re-

produce sound) are also transmitted via the cabinet structure to the tone-arm and pickup, the fairly violent vibrations of that speaker (needed to reproduce sound) are also transmitted via the cabinet structure to the tone arm and its phono pickup stylus. If you try to turn up the volume to life-like levels, the vibrations generated by the speaker system can initiate a "vicious circle." They are re-amplified by the record player, reproduced as greater and greater vibrations from the speakers and so on, until the entire system takes off in an annoying "howl" which is called "acoustic feedback."

Interestingly, most all-in-one systems do not exhibit this phenomenon. The reason they don't is because the electronics built into such systems is generally restricted in its ability to reproduce all musical tones in their proper relative intensity. Since low-frequency tones (bass) involve more intense vibrations, the ability of the electronics of such systems to reproduce those tones is often severely restricted. In other words, you don't hear all the music contained in the actual record!

The first requisite of a true high-fidelity system is that it reproduce all musical tones faithfully. So it's imperative that loudspeakers are separated from the rest of the system—a condition easily achieved with separate components. Faithfulness of musical reproduction also means that sounds must not contain more tones than were present in the original program. In high-fidelity terms, that means low or negligible distortion. Distortion, broadly defined, includes any extraneous sounds such as harmonically related tones, electrically generated hum, or random noise or hiss. In short, the reproduced music should be an exact replica of the original performance as contained in the record or other program source. The minimal electronics, poor-quality record players, and undersized, un baffled loudspeakers contained in most all-in-one radio-phonographs and "compacts" are simply incapable of this kind of reproduction.

Building-block Flexibility. There are other distinct advantages in the component approach to high-fidelity sound. Over the brief history of high fidelity we have witnessed a progression from monophonic sound (in which all music is reproduced in one-dimensional form from a single loudspeaker), to two-dimensional stereophonic sound (in which two speakers are used to give the listener an added sense of spatial real-

ism), to 4-channel or quadraphonic sound (in which the listener gains true concert-hall ambience reproduced from four properly positioned loudspeakers). Owners of "compacts" or consoles found their equipment hopelessly obsoleted as each of these advances gained acceptance. Owners of quality component systems, on the other hand, were able to update and add to their basic systems without any loss of their original investment.

Clearly, this building-block approach to good sound makes sense economically. As a further example, suppose that your primary interest is in a good record-playing system. You might elect to purchase a system consisting of a good amplifier, a pair of speakers, and a separate turntable or record-playing system at the outset. Then, if taste and budget dictate, you can add a stereo FM/AM tuner at a later date, connecting it in seconds to the system you already enjoy. You might also wish to upgrade one component in a system while retaining the others, which is easily achievable with an audio component system. Finally, you might even want to add tape recording and playback facilities to your expanding system by purchasing a tape deck of the open-reel, cassette, or cartridge variety. All of these added program sources will utilize the basic amplifier electronics and speaker systems purchased initially. You may even want sound in other listening rooms (a bedroom, or a den). This can be provided by the addition of another pair of speakers which can be connected to most high-fidelity component amplifiers or receivers and switched in by means of suitable front-panel controls. Moreover, one can add an equalizer, noise-reduction system, or other accessory component to an audio component system in order to obtain more realistic sound.

Electronic Options. There are three

basic approaches to assembling the electronics of a hi-fi system. The most popular of these involves the purchase of a component called a receiver. This single unit will contain all the circuitry needed to pick up AM, FM, and stereo-FM radio signals, the necessary preamplifier and control circuits whereby program sources are selected and adjusted for proper listening, and the power amplifier section needed to drive the loudspeaker systems.

In the early days of hi-fi, all-in-one receivers were rather limited in their ability to deliver sufficient power to the loudspeakers. Today, you will find all-in-one receivers which boast power-output ratings higher than 100 watts per channel. Because all of the electronics is combined on a single chassis, the receiver represents the most economical approach to a hi-fi component system. A common power supply, a single front panel, a single cabinet enclosure and other parts-in-common result in savings that cannot be obtained from wholly separate components.

Nevertheless, a visit to your hi-fi dealer will reveal an array of separate amplifiers as well. So-called integrated amplifiers combine two of the three previously referred to electronic sections—the preamplifier-control portion and the power-amplifier section. We already mentioned a possible reason for choosing this option. You may want to forego FM and AM radio at the outset and concentrate on good record reproduction (or possibly tape). A tuner can always be purchased later and will interconnect easily with any integrated amplifier, even if your purchase is made many years from now. Furthermore, you will often find that an integrated amplifier has additional control refinements and perhaps more signal input facilities than an all-in-one receiver—another possible reason for its selection as the basic component of a system. You may also



be able to purchase a more powerful integrated amplifier for the same amount of money that would be required for a more moderately powered complete receiver unit.

A third option, offering perhaps the greatest flexibility of all (and generally the most costly), is to purchase a separate tuner, a separate preamplifier-control unit, and a separate *basic power amplifier*. This arrangement is not nearly as popular as the other two, and usually represents the choice of those audio enthusiasts who demand the ultimate in flexibility, superior performance specifications (lowest distortion and very-high-power-output capability), and other operating features not found either in complete receivers or integrated amplifiers.

Irrespective of which of these three types of component systems you choose to assemble, you'll want to familiarize yourself with the more important technical performance specifications listed in manufacturers' advertising brochures. Tuner, preamplifier, and amplifier specifications mean the same thing whether they are used to describe those individual sections in a complete receiver, an integrated amplifier, a separate tuner, a separate preamplifier-control unit, or a basic power amplifier.

What about 4-channel sound? Multiple-channel sound is certainly not new. As early as the 1930's, moviegoers thrilled to the multi-channel Walt Disney production of "Fantasia," in which listeners were surrounded by music reproduced over as many as six separate speaker systems. For many years, recording studios have used multiple tape tracks to record individual instrumentalists and vocalists under optimum studio conditions. These tape "tracks" were then "mixed down" to two-channel "stereophonic" final products in the form of stereo records. Only in 1970 did 4-channel sound reach the home music listener—first as 4-channel tapes and later in a variety of disc formats.

Musically, there are two distinct approaches to 4-channel sound. The "classical" approach involves the reproduction of the ambience of the concert hall itself. Any concert goer will readily admit that much of the sound he or she hears at a live concert is reflected from the walls and ceiling of the hall itself, rather than from the performers on stage. It is this ambient quality which distinguishes the live performance from its recorded and reproduced equivalent in a home listening room of restricted dimensions. By recording two additional channels, using microphones at the rear

of the concert hall and reproducing these channels over similarly positioned speakers behind the listener, it is possible to create a sense of vast space in the home listening environment which is not achievable with conventional two-channel reproduction systems.

Given the extra pair of channels, it is also possible to assign different instruments or soloists to specific channels so that the listener finds himself in the center of the "performance" when playing back recordings. This alternate recording approach to quadraphonic sound is particularly effective when applied to modern pop and rock music, affording the listener a sense of involvement not otherwise attainable.

Recording four channels on tape is relatively simple. Both 8-track cartridges and open-reel tapes have multitrack capability. Cassettes do not.

In the case of phonograph records, there are two basic systems. One called "matrixing," is a process of combining or encoding the four original program channels into two complex audio programs. These two "encoded" channels can then be applied to the record groove much like a stereo program. Suitable decoder circuits, often built into a four-channel amplifier or receiver, "decode" the two channels into four separate signals approximating those which were recorded at the beginning of the process.

The two most popular matrix techniques currently in use in the United States are the SQ system, developed by CBS and the QS system developed by Sansui. Both are capable of excellent 4-channel reproduction and each can be further enhanced by the addition of circuits called "4-channel logic" which increase apparent separation between channels. In addition to matrix records, there are also so-called discrete or CD-4 records which actually contain four separate programs in the single record groove. Because of the very high frequencies contained in these CD-4 discs (developed jointly by RCA and the Japan Victor Company of Japan), a new cartridge or phono pickup is required. Moreover, a turntable used for playing CD-4 records should have low-capacitance phono cables for best results.

A 4-channel home music system is necessarily more costly than a stereo system of equal power and performance capabilities. Any 4-channel system requires four separate loudspeakers as well as four amplifiers (the latter often combined in one unit).

Before deciding whether to buy 2- or 4-channel equipment, listen to each type

of system in a properly equipped demonstration room at your audio dealer. Bear in mind that, whether you elect to buy 4-channel or stereo, the important criteria of low distortion, good frequency response, and adequate power output apply to each type of system. If your budget is limited, you might be better off starting with a good stereo component system rather than settling for an inferior quadraphonic system. Separately available decoders, demodulators, and extra amplifiers and speakers can be added to any existing stereo sound system at any time in the future.

Hi-Fi Shopping Tips. Shopping for a hi-fi component system can be fun—or it can be a frustrating experience. There are four general sources of supply. (1) You can visit an audio specialist dealer who sells nothing but high-fidelity component equipment. (2) You can shop in a branch of one of the many electronic-supply stores that sell other specialized electronic equipment in addition to hi-fi, but generally have listening rooms set aside for hi-fi component selection. (3) You can order components from a variety of mail-order or catalogue houses (some of whom also have retail stores in many cities), or (4) you can visit a "discount" establishment which has a variety of merchandise available in sealed factory cartons but provides no facilities for equipment auditioning. Your choice of supplier will generally depend upon how much (or how little) personalized service you require.

The first two categories of retail establishments generally offer the most service. If you are starting from "scratch," it is essential that you be able to listen to the components you plan to buy. As a matter of fact, the first components you should select are your loudspeakers, since there is the greatest variation in sound amongst the hundreds of speaker models currently available. Zeroing in on the loudspeakers that sound best to you also puts you in a better position to decide on how powerful an amplifier or receiver you will need, since some speakers require far more power than others to deliver a given loudness level.

Generally, the well-equipped audio dealer who offers auditioning facilities and technically trained sales personnel will offer less of a discount than the "mail order" or "warehouse" type of retailer, since his overhead costs are higher. In return for the somewhat higher price you pay, you will obtain the aforementioned advantages that may or may not be important to you. ◇

Dynamic Noise Reduction Systems and Expanders

BY WILLIAM S. GORDON

THE QUEST for noise reduction in high-fidelity equipment has challenged audio engineers for decades. As far back as 1947, H. H. Scott introduced a "Dynaural Noise Suppressor," to deal with the noise problem; and the Dolby noise-reduction system (professional version) was demonstrated in the mid-sixties. The age of noise suppression was really ushered in for serious audiophiles, however, when the Dolby NR system was incorporated into cassette decks in the late sixties.

Since then, a great deal has been done to make noise reduction a realistically inexpensive and practical means of obtaining the maximum enjoyment out of hi-fi equipment. In this article, we will examine a host of noise-reducing systems that have come onto the consumer market and describe how the different schemes work.

Two Categories. Noise-reduction systems can be grouped into two categories: Those that rely on preprocessed (encoded) signals and those that operate on "raw" (unprocessed) signals. Examples of the first category are the Dolby A and B systems, JVC's Automatic Noise Reduction System (ANRS), and the dbx system. In the latter category are Phase Linear's "Autocorrelator," Philips' Dynamic Noise Limiter (DNL), and Burwen's noise-reduction system.

The devices that encode the signal before recording or transmission first pass the signal through an encoder and then through a decoder. In essence, these "two-pass" systems are noise-preventive devices because they do nothing to remove noise already in the program but attempt to prevent it from creeping in between the encoder and decoder. The unencoded "single-pass" systems attempt to remove noise already in the program.

Two-pass processors generally employ complementary signal compressors and expanders, called companders. During processing, the dynamic range of the signal is compressed so that a two-fold increase in the input signal causes

less than a two-fold increase in the output. The actual input/output characteristic depends on the compression ratio used. For example, a 3:2 ratio causes a 2-dB output increase for every 3-dB increase in the level of the input signal. This means that a 60-dB dynamic range can be compressed into an output signal with only a 40-dB range.

Compression is important because the dynamic range of many program sources exceeds the range of modern state-of-the-art hi-fi equipment, especially tape recorders and FM tuners. A symphony orchestra can have an 80-dB dynamic range, but a recorder might have a range of only 55 or 60 dB. By using a 2:1 compression ratio, the entire 80-dB orchestra range can be compressed down to 40 dB, which is well within the average recorder's capabilities to handle.

The signal-to-noise ratio (S/N) can give you an idea of the capabilities of a piece of equipment. The maximum level a device can handle is determined by the point at which distortion reaches an unacceptable level (generally 3% THD in consumer equipment and 1% in pro-

fessional equipment). The minimum level that can be handled is determined by the "noise floor." Signals that are lower in level than the residual noise of the equipment are lost in the hiss and hash at the noise floor.

With sufficient compression, a wide dynamic range program can be squeezed into the limited range available in a tape recorder. This assures that the program peaks will not be too high to handle, while keeping the minimal signals above the noise floor.

A compressed signal must be expanded to restore its original dynamic range. An expander is the mirror image of a compressor. In it, a two-fold increase in program level at the input results in a greater than two-fold increase in the expander's output signal. To restore the original dynamics of the signal in the above example, a 2:3 expansion ratio would be used. Hence, the 40-dB compressed signal would be expanded back up to its original 60-dB dynamic range. This opens up the top of the range and simultaneously pushes down the noise floor. The net effect appears as a reduction in the residual noise, so

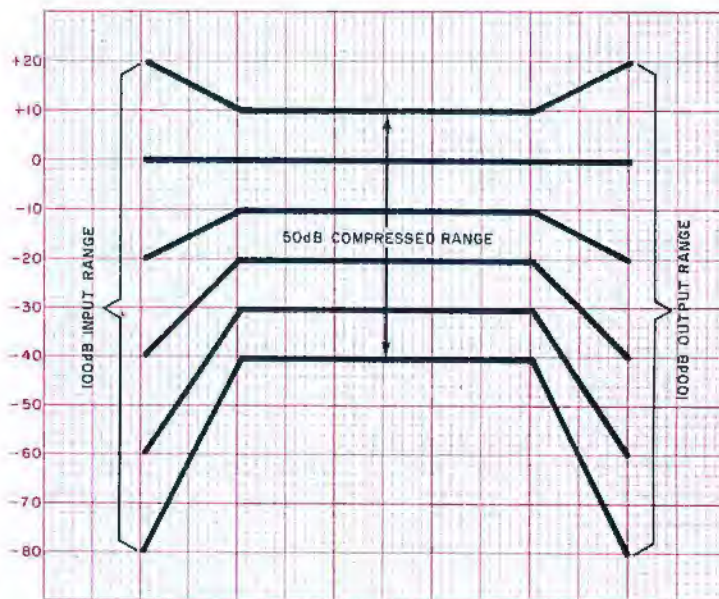

The 2:1 linear compander characteristic of the dbx system illustrates how dynamic range is compressed and then restored.

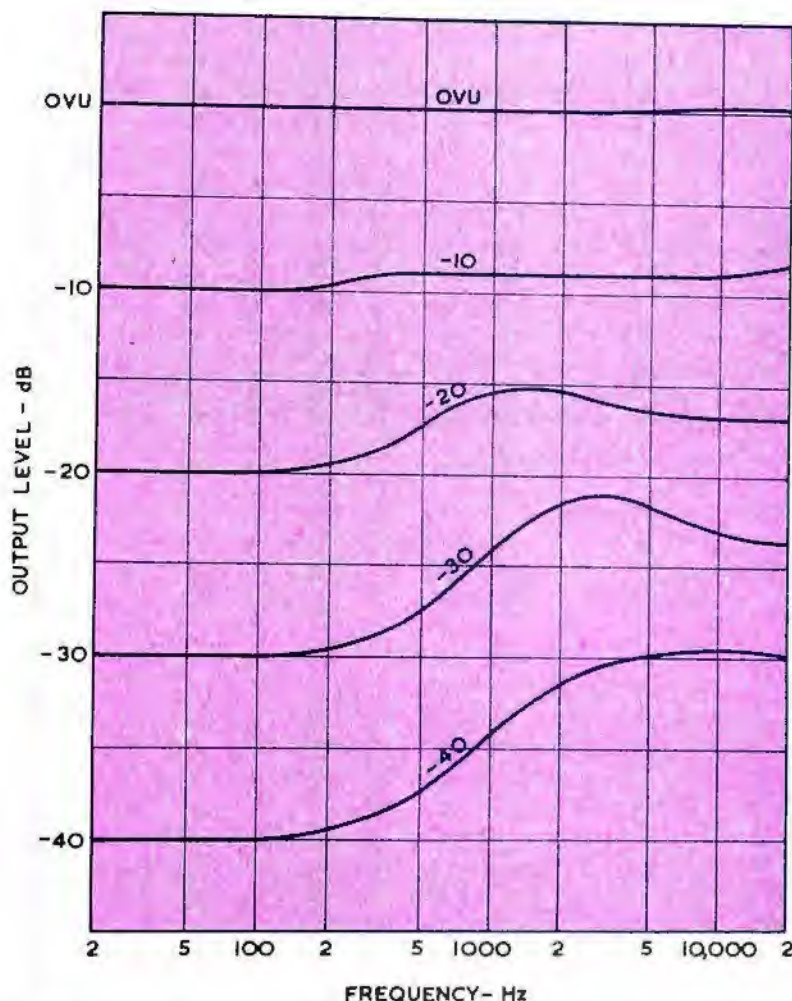

Dolby encoding characteristics show output level changes in decibels versus frequency over entire 20-to-20,000-Hz range.

the system qualifies as a "noise-reduction" system.

How Companders Work. Compressors and expanders are basically amplifiers whose gain is varied by a voltage. (Such a device is known as a voltage-controlled amplifier, or vca.) They also include detectors that measure the signal level and produce the voltage that controls the gain of the amplifiers.

The time constants of the detector circuits must be chosen very carefully. If they are too short, the detector responds very rapidly and follows the low-frequency signals. The vca's gain "chases" the low-frequency signals, increasing distortion and modulating the rest of the signal with a low-frequency tone. A very long time constant causes the detector to respond very slowly to the average signal level. Sudden transients get through before the gain of the vca can be reduced. The transient will not be compressed and will cause the system to overload. Since the transient is detected, the signal for the vca to reduce its gain will be delayed. Then, an audibly discrete inter-

val later, the vca's gain reduces where no reduction is required and a "dropout" will be heard in the program.

Another audible flaw in wideband, widerange companders is "breathing." When the input signal disappears or is greatly reduced in level, the gain of the compressor increases and boosts the level of any noise present in the signal. When the music level increases, the level of the noise decreases, and when the music level decreases, the noise floor comes up. As the system operates under these conditions, it sounds like it is "breathing." Note that this is not noise introduced by the recorder between the compressor and expander (which is reduced by compander action) but noise in the signal prior to compression.

Enter the Dolby System. The Dolby noise-reduction system was originally designed to combat the problems inherent in companders. The professional Dolby A system divides the frequency spectrum into four bands, each of which is processed separately. This was done so that an increase in midband energy

would not reduce the level of the lows and highs. Where there might be a lot of midband energy but little high-frequency content, the processor reduces the midband level to avoid overloading the recorder. At the same time, it keeps the gain at the high end up so that the highs are not pushed down near the noise floor. This is important because psychoacoustic tests reveal that low-frequency signals do not mask high-frequency noise, nor do high-frequency signals mask low-frequency noise. (Masking psychoacoustically makes one less aware of noise when a strong signal is present than when it is absent. Masking of noise is effective only in the frequency range of the signal; hence, Dolby's use of the four-band approach to the problem.)

The Dolby system employs the processor only on low-level signals, which are boosted above the noise floor, while high-level signals emerge unchanged. The lower the level of the signal, the greater the boost. Hence, the processor is used only when signal levels approach the noise floor. The action of the system is less noticeable to the listener and overcomes the objections of previous full-range companders.

The final improvement in the Dolby system is that the attack time of the compressor is variable. If the signal level increases dramatically, the attack time is very fast to minimize the time the system is overloaded. For less severe increases in level, the attack automatically slows down to minimize low-frequency distortion and modulation of the music by low-frequency tones.

Having become the standard of the professional recording industry, the Dolby A system was later simplified and became the Dolby B system familiar to consumer products. The B system reduces cost by processing signals in only the band where high-frequency hiss resides. To make it more effective, the processor's upper frequency cutoff is made to automatically vary with signal level. As the level drops, the system processes a larger bite of the upper-frequency band. Since hiss is the major source of audible noise in hi-fi tape recording, the system is quite effective.

Since only low-level signals are processed by the Dolby A and B system and in the consumer B version only a portion of the audible band is processed, there is a limit to how much noise reduction can be achieved. In the case of the B system, this is approximately 10 dB. And since the processor does not operate over the entire dynamic range of the

signal, the signal must be standardized and matched for the decoder to properly track the encoder. Hence, the reference level, the so-called "Dolby Level," must be maintained to calibrate the chain.

It is the signal itself that "tells" the decoder where and how much expansion to use. If the level into the decoder is too low, the expansion will begin at too high a level. This will upset the original balance of the program. Similarly, if the input to the decoder is too high, expansion will not occur soon enough.

JVC followed Dolby's lead with its ANRS device, which functions in a manner quite similar to the operation of the Dolby B system. In fact, Dolby B tapes can be decoded by the ANRS circuit with quite good results.

The dbx System. The foremost competitor of the Dolby system is the noise reduction system developed by dbx Inc. This is a "classical" compander in that it operates over the entire dynamic range of the music. However, it has improvements over previous companders that make its action virtually inaudible.

The dbx system is a linear 2:1 compander that compresses the 80-dB dynamic range of the symphony orchestra down to a mere 40 dB. On the decoding end, the 40-dB range is expanded back up to 80 dB, pushing down the noise that was introduced by the tape-recording process to an inaudible level.

Since the dbx system operates linearly over the full dynamic range, matching of signal levels is not particularly important. Any 1-dB rise in input results in a 2-dB rise at the output of the expander. There is no "threshold" below which the system operates as there is in the Dolby B system. (Note, however, that any irregularities in recorder frequency response or any amplitude perturbations, such as dropouts, that are introduced will be magnified by a ratio of 2:1.)

One way dbx avoids the problems of classical companders is that it employs an rms detector to drive the vca, rather than the usual peak or average detector used by previous companders. The rms detector measures the power of the signal and is unaffected by the phase distortion introduced in the taping process. Peak or averaging detectors, on the other hand, are affected by phase shifts.

Another solution is the use of variable attack times that quickly respond to large changes in level and slowly respond to small changes. Both attack and release times vary with the signal level and are optimized to simulate the time response of the human ear.

The final solution is the use of high-frequency preemphasis before compression with complementary de-emphasis after expansion. This helps to reduce the effect of breathing by a factor of 12 dB.

The S/N improvement of the dbx system is in the range of 40 dB, which contrasts sharply with the 10-dB improvement provided by the Dolby B system. Although the Dolby system has a huge head start in the recording industry, there may soon come a time when the system developed by dbx will replace it as the standard one in use.

Single-Pass Systems. So far, our commentary has focused on two-pass systems designed to reduce noise only during the recording (or transmitting) process. Such systems do not reduce the noise already in the program. A great deal of work has been done to remove the noise already in the program, and the result is the single-pass system.

Two of these new systems are the Philips DNL and Burwen DNF that are both dynamic low-pass filters. The Philips system was developed specifically to reduce noise in unencoded cassette recordings. (It is not widely available in the U.S.) The Burwen system is more flexible and can be used for tapes and discs. Both systems consist of low-pass filters whose cutoff frequencies are automatically controlled by the program level. When there is a lot of high-frequency program energy, the filter "opens up" to let it through. Then when the high-frequency program energy is small, the cutoff frequency of the filter shifts downward to cut out the highs and the hiss. In essence, if there is enough high-frequency program energy to mask the hiss, the bandwidth of the DNF opens up to 30,000 Hz. But if the highs are missing and, hence, are unavailable to mask the hiss, the bandwidth narrows. In the absence of any signal, the Burwen DNF system starts to roll off above 500 hertz.

The constants of the detector circuit that senses the program level are critical. The filter must open up rapidly to let a transient through and should close down rapidly to prevent a burst of noise from following a brief transient or record tick. However, too fast a response tends to be audible. Consequently, the attack and release times are made variable according to the magnitude of the signal change. Depending on the program material and the control settings, the newest Burwen system provides from 5 to 14 dB of noise reduction. Since it is a

single-pass system, it operates on any program source.

The Phase Linear "Autocorrelator" is more complex than the dynamic noise filters. It actually attempts to distinguish between music and noise by electronic means. Noise is typically random in nature and contains many frequency components that are not related to each other, which makes it incoherent or uncorrelated. Music, on the other hand, contains mathematically related tones and is coherent, with a high correlation factor. The Autocorrelator consists of band-pass filters and a circuit that analyzes the signal for its degree of correlation. If it determines that the signal is music, it passes it through and those filters that correspond to the harmonics of the signal are activated to pass the overtone structure. If the signal is determined to be noise, the filters close down. It is obvious that this is a more sophisticated approach to noise elimination than the dynamic noise filter.

Another sophisticated type of noise-reducing device is SAE's Model 5000 pop and click filter. The premise used here is that clicks and pops are characterized by a rapid rise and decay, while music should exhibit a more gradual decay. Once a click or pop has been detected, that section of the program is gated out and the previous program section is recalled and inserted in its place. Since the click or pop is very short in duration (on the order of 1 ms), this substitution goes undetected by the ear.

Most of the time, the Model 5000 remains completely passive. A threshold control establishes the sensitivity of the detection circuit. This is necessary because different records may exhibit slightly different characteristics.

Conclusion. So far, noise-reduction systems have provided some impressive results. The effort to develop better systems is still going strong, but what the future has in store is difficult to predict. As things now stand, the most dramatic steps have been taken to reduce noise. Most of what is left is the refinement of the systems we now have and the addition of a few more decibels of noise reduction.

One or more of the noise-reducing devices we have mentioned certainly has a place in every high-quality hi-fi system. In fact, we can expect to see these devices incorporated into higher-quality hi-fi amplifiers and receivers in the future, just as all high-fidelity cassette decks now have noise-reduction systems built into them. ◇

Matching Tapes to Recorders

BY LEN FELDMAN

WHETHER you own a new open-reel tape deck or a super-performing stereo cassette deck, you'll have to decide which type of tape to use to get the best possible performance. If cassettes are what you need, you can buy a 60-minute (C-60) cassette tape for as little as 99¢ or you can spend up to \$5.00 for the same amount of recording time. In the case of open-reel tapes, an 1800-ft (550-m) reel may cost less than \$6.00 or you may spend more than twice that amount for the same tape length. Which kind of tape you buy will depend on the type of recording you intend to do and the kind of tape deck you own.

For open-reel tape, selection involves physical considerations almost as much as electrical performance or fidelity. Broadly speaking, the two basic "grades" of tape are "standard and "high-energy," each of which requires a different bias setting on your machine. Lower priced standard tapes often have more residual noise and somewhat poorer frequency response than "premium" tapes, though they may be suitable for noncritical recording applications.

Generally, 1-mil-thick tape, with its 1800-ft capacity on a 7-in. (17.8-cm) reel, offers the best compromise between tape storage bulk and playback quality. Almost all open-reel tapes use ferric-oxide particle coatings even though there are still some differences between the products of different manufacturers. Mechanical differences in reel construction and accuracy of tape splitting and dimensions and uniformity of coatings account for the wide differences in prices.

In contrast to open-reel tape recording, the quality of recording obtained with a cassette deck is more critically dependent on the compatibility (or lack of it) between the tape and the machine with which it is used. A growing number of tape deck manufacturers make specific recommendations of tapes that work best with their products. However, even these suggestions require an understanding of the kind of recording to be made and the nature of different tape formulations.

Correct Bias. A high-frequency bias signal must be added to the program signal to be recorded to reduce the dis-

ortion normally caused by the nonlinear transfer characteristic of magnetic tape. However, not all tape formulations require the same amount of bias for best results. Normally, ferric-oxide coated tapes require less bias than do chromium-dioxide (CrO_2) tapes. Several new formulations that combine ferric-oxide particles with other elements such as cobalt (in a single-compound layer) also require the high bias settings of CrO_2 .

In cassette tape testing, most manufacturers determine the correct reference bias for a given tape by recording a fairly high frequency (usually around 6300 Hz) onto the tape while observing playback output as bias is gradually increased. At some bias setting, the output reaches a peak, after which a further increase causes the output level to drop off. The reference bias for the tape is set at the point where the output level has dropped off by about 2.5 dB beyond peak. Usually, a standard reference tape is tested in this way, and its optimum bias point is identified as the "0 dB" reference bias. Then, the tape under investigation is compared with the 0-dB reference bias specified in dB.

In Fig. 1 are shown the results of this test when performed on a well-known, low-noise, ferric-oxide tape. The optimum bias has been established at a -1-dB setting, relative to the standard

0-dB bias point. In Fig. 2, the same test was performed on a CrO_2 cassette; and the optimum point for bias was +2 dB (with reference to the standard 0-dB bias point of the reference tape). This means that the CrO_2 tape requires a bias setting that is 3 dB higher than that for the low-noise, ferric-oxide sample.

For any practical tape, the bias strength that results in the highest output at middle and low frequencies is greater than the ideal for high frequencies. Conversely, if the bias is adjusted to favor the highs, the middle and low frequencies suffer in terms of realizable output. Whatever bias point is selected, some degradation of signal-to-noise (S/N) ratio and overload distortion will occur in some part of the audio frequency spectrum. While increased bias tends to reduce distortion, no one setting can guarantee overall distortion reduction by the maximum amount at all frequencies. Thus, bias settings are always a compromise, and the best tape permits the most favorable compromise.

To demonstrate the effect of overbiasing and underbiasing, we recorded a continuously sweeping series of frequencies (20 to 20,000 Hz) on a strip of ferric-oxide tape at a fairly high recording level. The results are shown in Figs. 3 (underbiasing) and 4 (overbiasing). Note in Fig. 3 that high-frequency re-

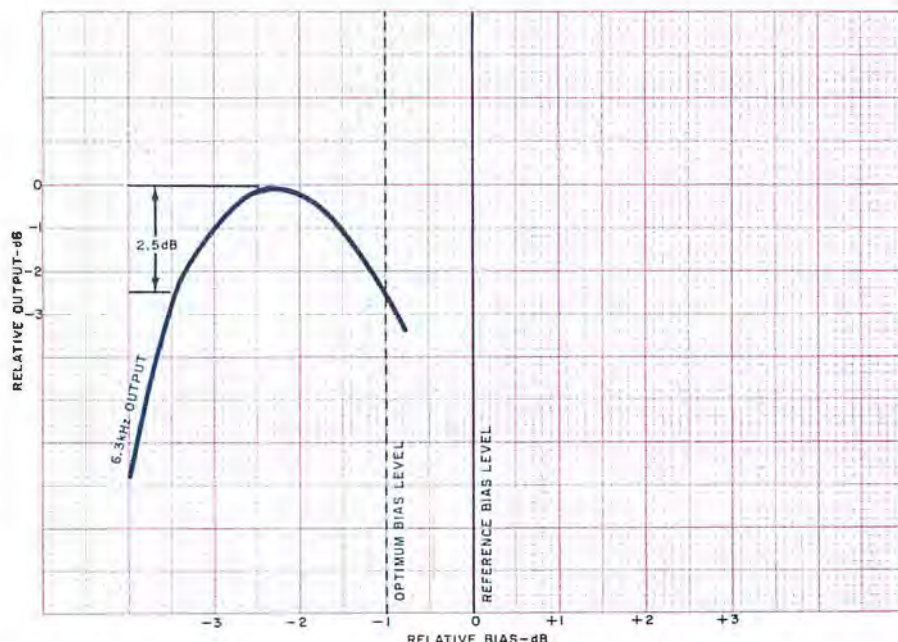

Fig. 1. Determining the bias level for a sample low-noise tape.

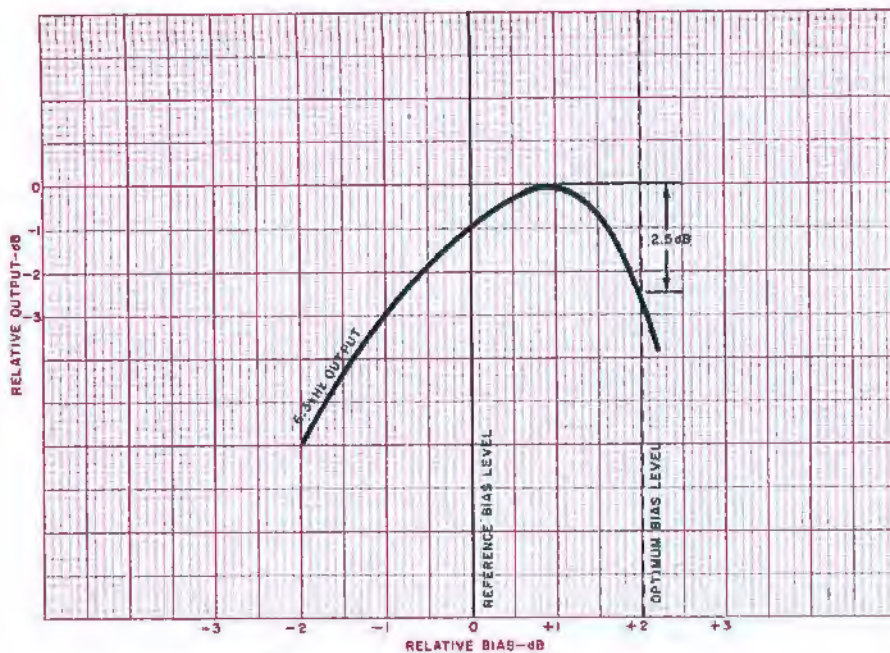

Fig. 2. Determining the bias level for a sample of CrO₂ tape.

sponse obtained in the underbiased condition is excellent. In fact, there is even a slight rise in response above 10,000 Hz before the response rolls off in the 20,000-Hz region. In Fig. 4, however, the response begins to fall off gradually above 1000 or 2000 Hz and really takes a giant dip beyond 10,000 Hz. Each vertical division in the photo equals 10 dB of amplitude.

From the results shown in Figs. 3. and 4, one might conclude that the best performance from any tape is obtained with underbiasing. However, the curves do not reveal what happens to harmonic distortion if a given tape's bias is set too low. In Fig. 5, the spectrum analyzer was used once more to examine the distortion and noise components of a reproduced 1000-Hz signal, as recorded on the underbiased deck. The large spike at the center represents the desired fundamental output (1000 Hz), while the spikes to the right, notably at 3000 and 5000 Hz, are components of third- and fifth-harmonic distortion. The third-harmonic component is only about 33 dB below the fundamental or about 2.2% of the signal content. The random spikes represent residual tape noise as reproduced during playback of the 1000-Hz recorded signal.

Figure 6 shows what happens to a 1000-Hz signal in the overbias condition that resulted in the frequency response of Fig. 4. The third-harmonic distortion component has gone down to about 44 dB below the fundamental. This corresponds to distortion of about 0.6% but there is little if any evidence of fifth-har-

monic contribution, and the general random noise content is much lower.

Equalization. Once the proper bias for a given tape has been selected, it is still possible to tailor the frequency-response capabilities of that tape by a process called equalization. Up to a certain frequency, if a recording is made on magnetic tape, the playback system "reads" that signal with a rising amplitude characteristic as the frequencies are increased. Since we want a "flat" frequency response, a rolloff in response is built into the playback electronics so that the net response, hopefully, will be flat.

Playback equalization in a tape deck is generally standardized and fixed to obtain reasonably flat playback results from any tape recorded on one tape deck and played back on another.

Recording equalization, however, is variable and is designed to match the particular tape you use and generally involves a specified amount of treble "boost" added to the record electronics to compensate for the high-frequency rolloff that occurs above a given high frequency. As with bias, record equalization is often adjustable by means of a switch on the deck's control panel. Most equalization switches have only two or three positions that generally approximate the right playback conditions for many of the tapes on the market.

In recent years, manufacturers of cassettes have tried to make tapes that give best results when used with the most commonly available equalization set-

tings of most machines. The two most popular settings of equalization are 70 and 120 μ s, the figures representing the time constant provided by the resistor-capacitor combination that gives the required 6-dB/octave response slope. The 120- μ s equalization setting begins to boost high frequencies during recording at a lower turnover point than does the 70- μ s setting that has been standardized for CrO₂ tapes and some of the more exotic ferric-cobalt tapes.

Let us see what happens to the response if the wrong setting is used for a given tape during the recording process. For one series of tests, a ferric-cobalt tape requiring the 70- μ s equalization was used. After adjusting the bias for optimum, the proper equalization switch position was set and a frequency response check was run. The result (the lower trace in Fig. 7) shows a good, flat response curve, similar to that shown in Fig. 3, but with somewhat greater rolloff at the high end because of the correctly adjusted bias. Without altering the bias setting, the run was repeated with the 120- μ s equalization setting. The result is the upper trace in Fig. 7. Overboosting during recording resulted in an overemphasized rising high-end response during playback.

Next, a low-noise ferric-oxide tape was tried. It normally requires the 120- μ s equalization characteristic. With this equalization and the correct bias setting, we obtained the upper trace in Fig. 8. The response is nice and flat to well beyond 15,000 Hz. In a second sweep, the equalization switch was set to 70 μ s; and, as can be seen in the lower trace, the response during playback rolled off severely, starting at about 2000 Hz.

Characteristics. Here are details on other key specifications.

Sensitivity of a given tape is the decibel difference between the output and input levels when an input 20 dB below the reference level (0 dB) is recorded on a tape. If the recorder used for this test has been biased properly, equalized flat and input/output adjusted to be equal for a standard reference tape (a German DIN standard, known as Bezugsband 4.75/3.81 tape is often used as the standard), the data obtained is the sensitivity of the tape under test relative to the reference tape. For cassette tapes, 333- and 12,500-Hz tones are used for sensitivity tests. Typical results obtained for standard and high-output tapes are plotted against bias settings in Fig. 9. As can be seen at the "optimum bias" inter-

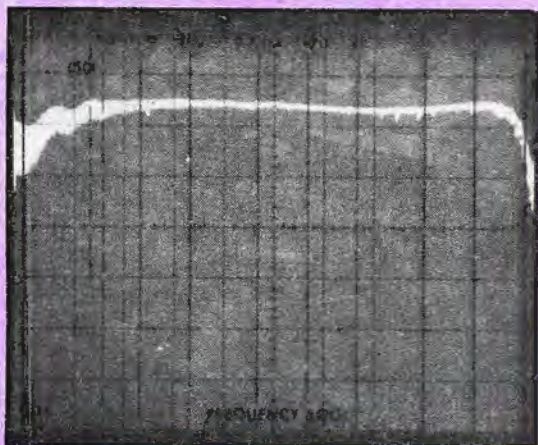

Fig. 3. Too low a bias may improve a tape's high-end response but degrade other performance characteristics.

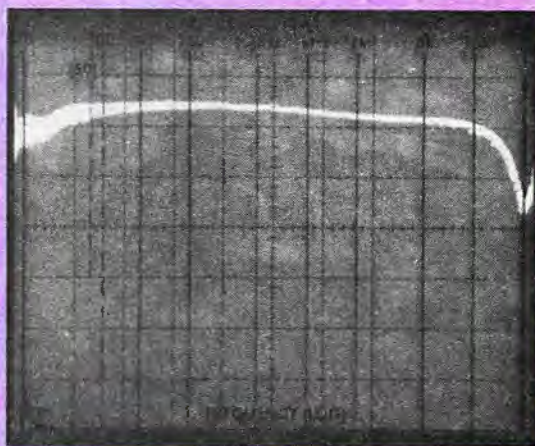

Fig. 4. Overbiasing causes high-frequency roll-off in tape playback as shown here.

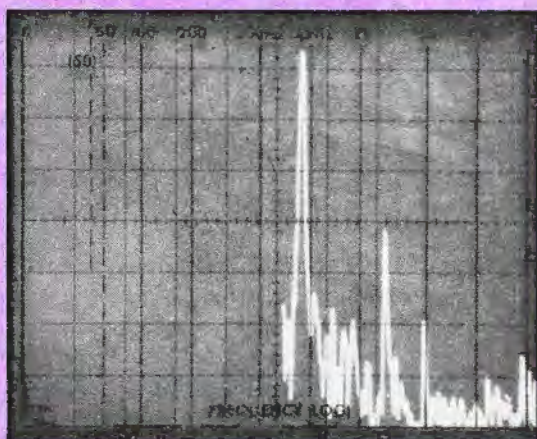

Fig. 5. Under-biased tape sample reproduces 1-kHz signal with high third-order harmonic distortion.

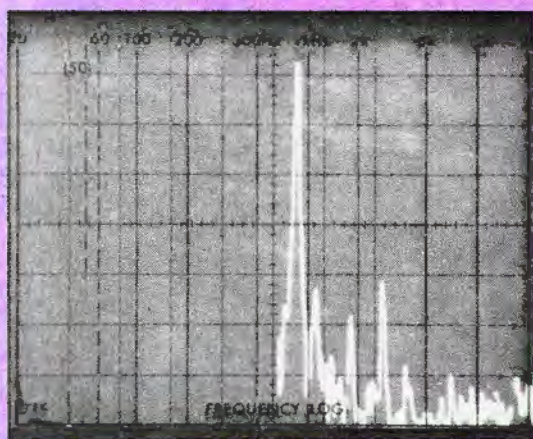

Fig. 6. Increased bias lowers third-order harmonic distortion content for this 1-kHz recorded test signal.

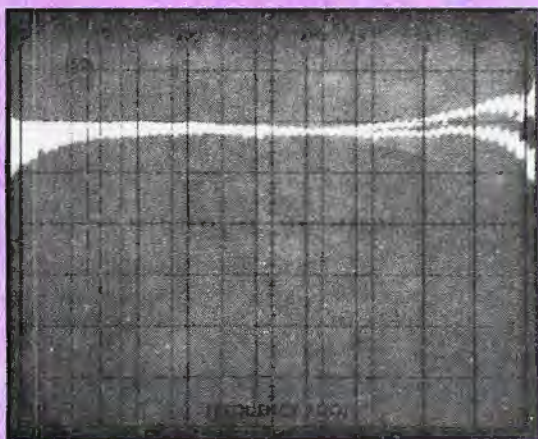

Fig. 7. Upper trace, with rising high-end response during playback occurs when sweep frequencies are recorded onto tape requiring CrO₂ equalization with switch set to "standard" position. Lower sweep was plotted using correct setting.

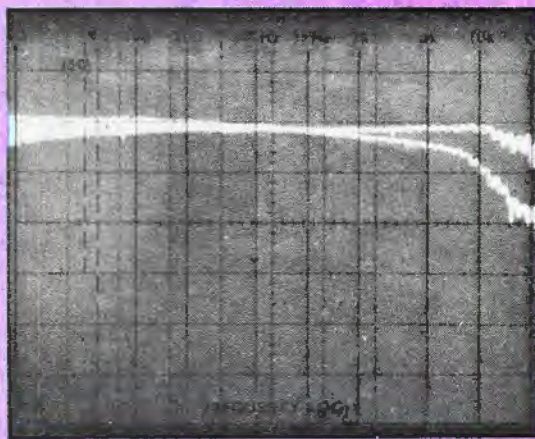

Fig. 8. When CrO₂ equalization setting is used with standard ferric-oxide tape, response at high end has severe roll-off (lower trace). Upper trace shows response obtained with correctly set equalization switch for this tape.

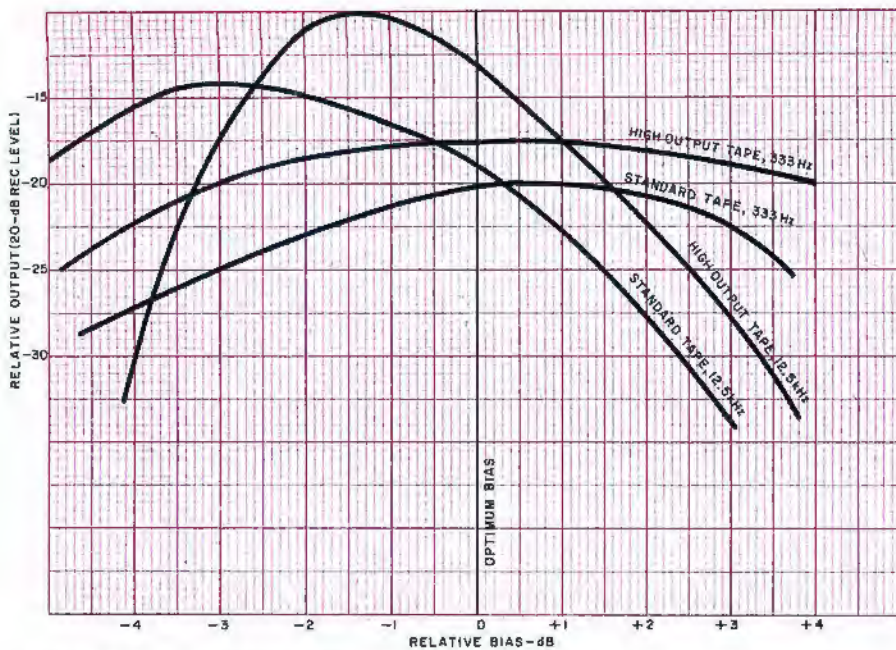

Fig. 9. Relative output sensitivities of standard and high-output tapes.

section, the high-output tape is more sensitive than the standard tape by nearly 2 dB at middle frequencies and by 6 dB at 12,500 Hz. This means that the higher-output tape affords a few extra decibels of dynamic range above the noise threshold.

Maximum modulation level is the recorded output level of a given tape that exhibits 3% third-order harmonic distortion. It is sometimes plotted as a function of bias level. In Fig. 10, are plotted the maximum output levels of two different tapes that have widely differing maximum output-level characteristics. The frequency used for maximum output lev-

el in cassettes is usually 333 or 1000 Hz. Some tape manufacturers also specify maximum output at a high frequency; in the case of cassette tapes, a 12,500-Hz signal is usually used for these tests.

Biased tape noise is also often specified by tape makers. This is the level of residual tape noise (referred to a specific reference level) when it has been recorded with bias signal only and with the bias signal weighted or modified by the use of a standard noise-weighting network. The biased tape-noise level for the two tapes tested in connection with maximum output level is also shown in Fig. 10. The difference between the noise

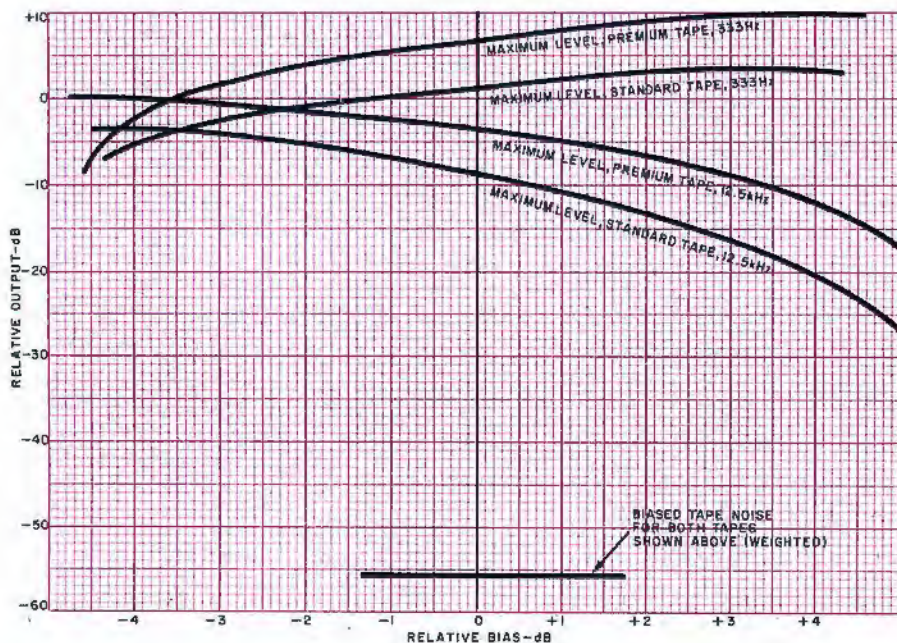

Fig. 10. Maximum output levels and biased tape noise for two types of tape.

level and the maximum modulation constitutes the maximum dynamic range of each tape.

Tape Is Different. As we have seen, tape cannot be looked upon in the same way that we consider other program sources in high fidelity, such as phonograph discs or FM signals. All discs are recorded with the same equalization and, therefore, only one fixed setting of playback equalization (RIAA) is required in preamplifier circuits. There are, of course, differences in disc quality that result from the use of different grades of vinyl from which discs are pressed. However, these differences are minor when compared with the differences that exist among the many grades of cassette tapes available.

Radio FM signals also employ a form of equalization known as "preemphasis," which has long been standardized in this country. Hence, all tuners provide correct deemphasis for FM reception, and difference in program quality depends on signal strength and the overall quality of a tuner or receiver.

In our discussion of the electrical properties of cassette tapes, we haven't stressed mechanical properties. These include: accuracy of tolerances maintained in the cassette housing (which can affect smoothness of tape travel); uniformity of magnetic coating and smoothness of the coated surface (both of which, if poor, can cause dropouts or momentary lapses of reproduced sound); tensile strength of the plastic base material itself (poor tensile strength can lead to tearing or stretching after repeated use); friction-reducing techniques used to insure smooth, uniform tape motion within the cassette housing; etc.

All of these qualities, in some measure, determine the price of a cassette and its usefulness for recording applications. Obviously, if all you want to record are baby's first words or a business conference, response to beyond 15,000 Hz is of little importance. (Though mechanical reliability of the cassette itself may be of as great importance as if you were recording a once-in-a-lifetime live concert over FM.) On the other hand, if you want the finest results from your cassette deck (or even from your open-reel machine), it pays to research the question of which tape is best for you. It is important to choose the brand and type whose formulation in relation to the switch setting available on your tape deck has the right "compromises" for your needs. ◇

IC Multiplex Decoder

Improves Stereo FM Performance

TODAY'S state-of-the-art audio components yield levels of performance unattainable a few years ago. However, most of us can't update our sound systems as frequently as technological advances are made. This project—an add-on phase-locked-loop multiplex decoder—will allow the user to improve the stereo FM demodulation of an existing receiver or tuner for about \$25. Only a few hours of assembly and alignment time is required. The PLL decoder will not only improve channel separation and lower distortion levels, but will also select deemphasis time constants for standard and Dolby-FM broadcasts.

About the Circuit. The heart of the PLL multiplex demodulator is the LM1800A, an IC manufactured by Na-

tional Semiconductor. A block diagram of the LM1800A is shown in Fig. 1. The phase-locked loop comprises a voltage controlled oscillator (vco), frequency dividers, phase detectors, low-pass filtering and an error amplifier. Also included are a voltage regulator allowing operation from 12-to-24-volt supplies, automatic stereo monaural switching, and use of a stereo indicator lamp.

In the absence of an input signal, no error signal is generated and the vco oscillates at a frequency designated as f_0 . When a composite FM signal is applied to the input, the loop phase detector generates an error signal which is filtered and amplified. This amplified error voltage shifts the oscillating frequency of the vco to exactly 76 kHz. Filtering performed at the phase detector and error

amplifier prevents modulation of the vco by the input signal.

The vco input frequency is divided by two, resulting in a 38-kHz carrier used in the synchronous demodulation of the composite signal. Passing the 38-kHz signal simultaneously through a pair of $\div 2$ counters produces two 19-kHz signals which are applied to the IC's two phase detectors. If the 19-kHz pilot signal drops below the level at which a satisfactory stereo signal can be recovered, an electronic switch causes the IC to produce a monaural output.

The schematic diagram of the complete multiplex detector is shown in Fig. 2. Input signals are capacitively coupled by $C5$ to level control $R5$. Capacitor $C4$ passes the composite FM input to the base of $Q1$, which amplifies it to a level

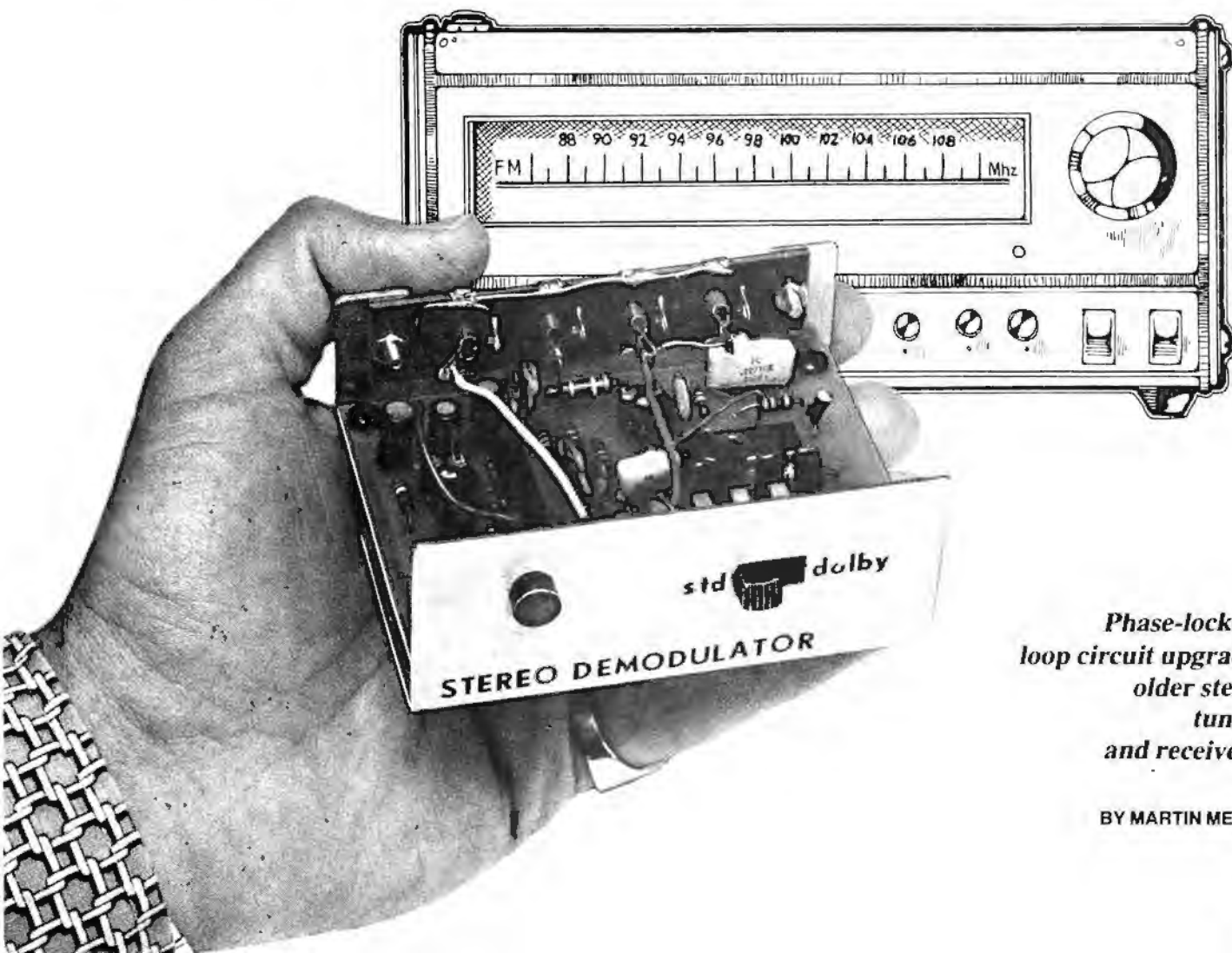

Phase-locked-loop circuit upgrades older stereo tuners and receivers.

BY MARTIN MEYER

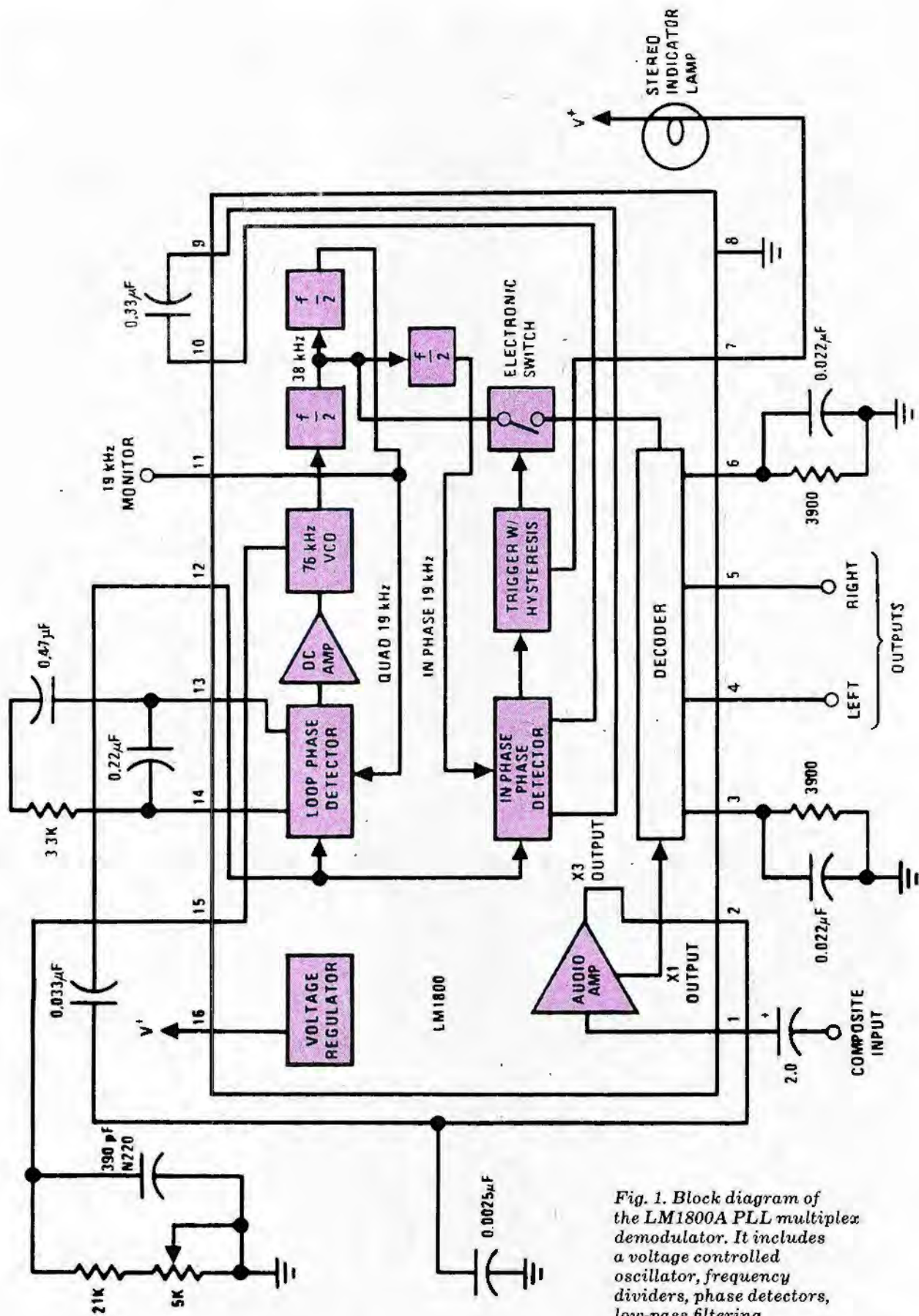
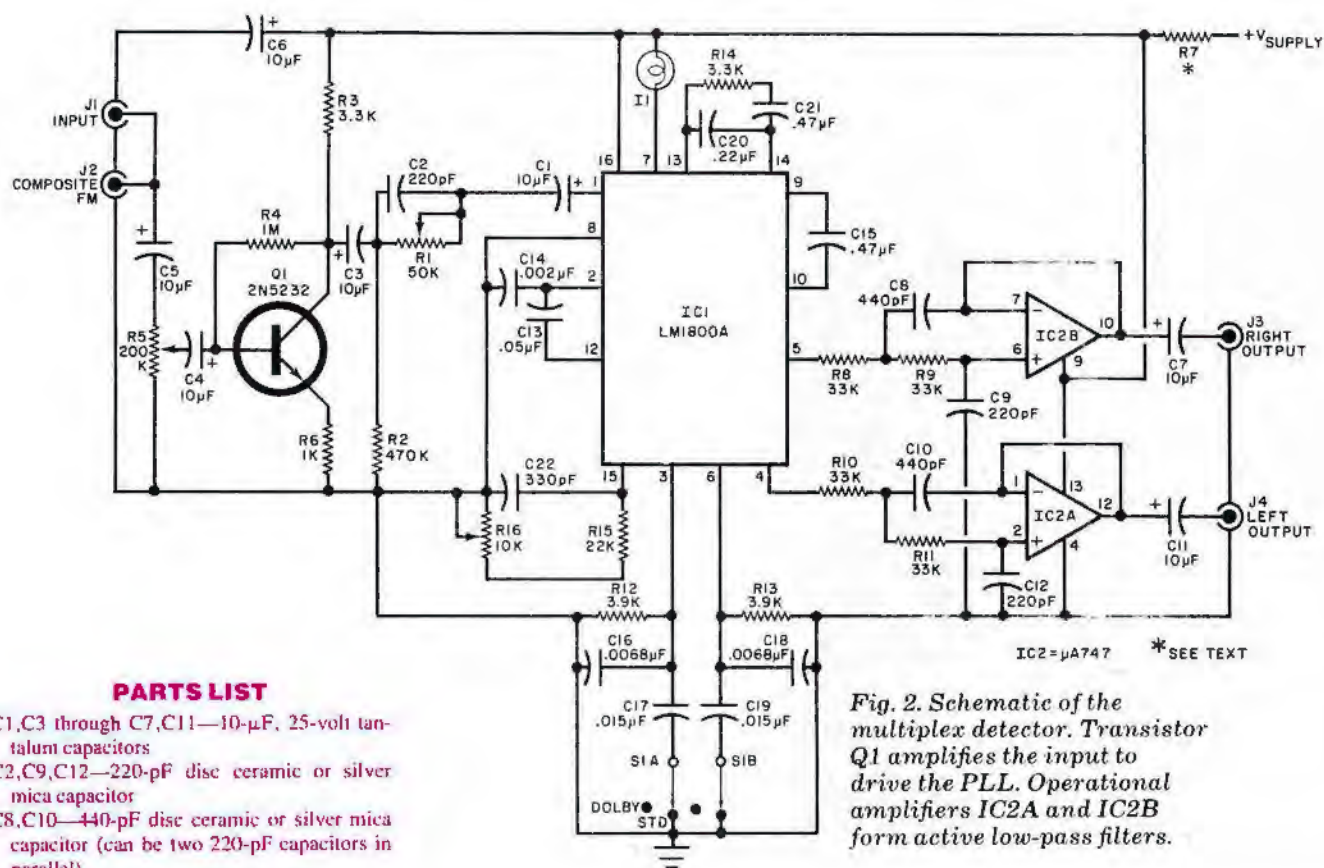

Fig. 1. Block diagram of the LM1800A PLL multiplex demodulator. It includes a voltage controlled oscillator, frequency dividers, phase detectors, low-pass filtering and error amplifier.



PARTS LIST

- C1, C3 through C7, C11—10- μ F, 25-volt tantalum capacitors
- C2, C9, C12—220-pF disc ceramic or silver mica capacitor
- C8, C10—440-pF disc ceramic or silver mica capacitor (can be two 220-pF capacitors in parallel)
- C13—0.05- μ F disc ceramic capacitor
- C14—0.002- μ F disc ceramic capacitor
- C15, C21—0.47- μ F Mylar capacitor
- C16, C18—0.0068- μ F, \pm 10% Mylar capacitor
- C17, C19—0.015- μ F, \pm 10% Mylar capacitor
- C20—0.22- μ F Mylar capacitor
- C22—330-pF disc ceramic or silver mica capacitor
- I1—12-V, 35-mA pilot light
- IC1—LM1800A PLL multiplex decoder
- IC2—747 dual operational amplifier
- J1 through J4—RCA phono jacks
- Q1—2N5232 npn silicon transistor

The following are linear-taper, pc trimmer potentiometers:

- R1—50,000 ohms
- R5—200,000 ohms
- R16—10,000 ohms

The following are 10% tolerance, $\frac{1}{4}$ -watt carbon-composition fixed resistors:

- R2—470,000 ohms
- R3, R14—3300 ohms
- R4—1 Megohm
- R6—1000 ohms
- R7—See text.
- R8 through R11—33,000 ohms
- R12, R13—3900 ohms
- R15—22,000 ohms

S1—Dpdt slide or toggle switch

Misc.—Printed circuit board, suitable enclosure, hookup wire, shielded cable, pilot light jewel, hardware, solder, etc.

Note—The following are available from Neronics Research and Development, Ltd., 333 Litchfield Road, New Milford, CT 06776: complete kit including all components, pc board, screened enclosure, less audio cables, \$24.95; complete kit as above but less screened enclosure, \$19.95. U.S. residents add \$1.50 postage and handling; Canadians add \$3.00. For receiver connection info, send schematic, SAS envelope and \$1 (free if purchasing kit). Connecticut residents add 7% sales tax.

Fig. 2. Schematic of the multiplex detector. Transistor Q1 amplifies the input to drive the PLL. Operational amplifiers IC2A and IC2B form active low-pass filters.

that will properly drive the phase-locked loop. The parallel combination C2R1 provides compensation for high-frequency rolloff in the tuner's i-f and detector stages. Resistors R12 and R13 and capacitors C16 through C19 provide deemphasis for multiplex decoder IC1. When S1 is in the STD position, the standard 75- μ s FM deemphasis characteristic appears. Placing S1 in the DOLBY position changes the deemphasis to 25 μ s, which corresponds to the reduced preemphasis used in Dolby-encoded broadcasts.

Operational amplifiers IC2A, IC2B, and their associated components form active low-pass filters with 16,000-Hz cutoff frequencies and 12-dB/octave slopes. These filters attenuate any 38-kHz carrier and 67-kHz SCA components which would otherwise appear at the left and right audio outputs. If allowed to pass, these signals could cause beats and whistles when program material is recorded on tape. Indicator I1 glows in the presence of stereo pilot carrier. Jack J2 is wired in parallel with input jack J1, providing access to the composite FM signal for such accessories as 4-channel and SCA demodulators.

Construction. Printed circuit guides for the project are shown in Fig. 3. Mount all components on the board, paying close attention to pin basing and

polarities of semiconductors and electrolytic capacitors. Power can be tapped from any +12- to +24-volt dc source. The tuner's i-f stage or existing multiplex decoder is usually powered by a +15- to +20-volt supply which can be utilized for this purpose. Select the value of R7 in kilohms according to the equation:

$$R7 = (V_{\text{supply}} - 12) / 55$$

A one-watt carbon composition resistor will have adequate heat dissipation capability for this application.

The tuning lamp used in the author's prototype (and supplied with the kit) draws 35 mA at 12 volts. If you substitute another incandescent lamp or a LED and current limiting resistor, modify the equation for the value of R7. Replace the 55 mA in the denominator with the sum of 20 mA (the current required by the PLL and active filters) and the

TABLE I
LM1800A SPECIFICATIONS

Stereo Separation—100 Hz: 40 dB
1000 Hz: 45 dB
10,000 Hz: 45 dB
SCA Rejection: 50 dB
Total Harmonic Distortion: 0.2%
Ultrasonic Frequency Rejection: 45 dB

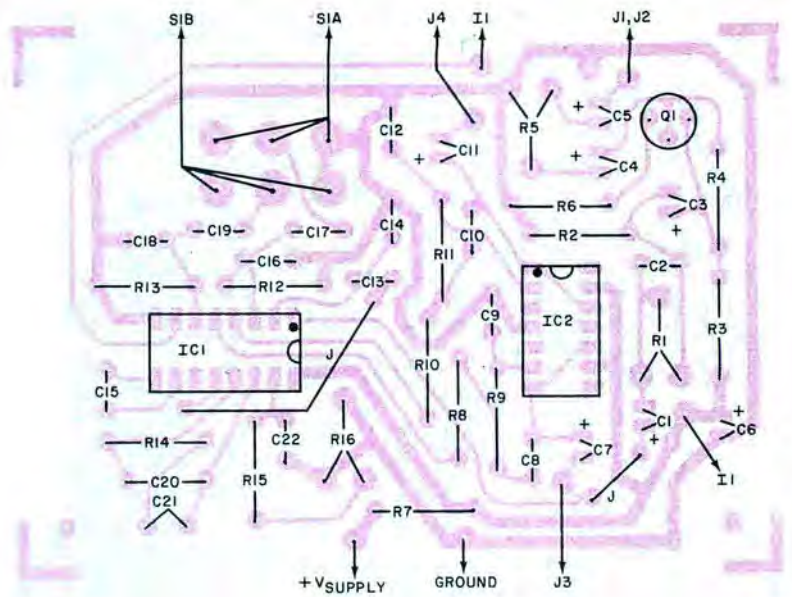
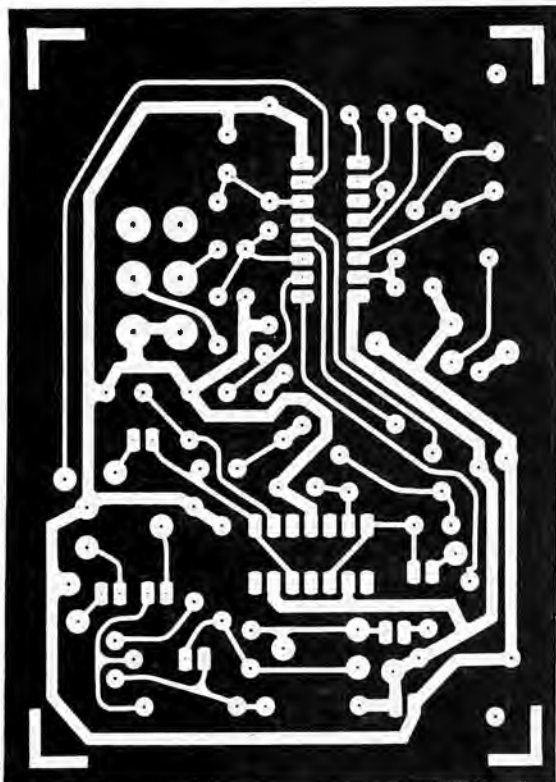

Fig. 3. Etching and drilling guide for multiplex decoder is shown at left. Component placement guide is above.

current required by the indicator. For example, if a LED and resistor drawing 20 mA are used, the denominator would be 40 mA.

The project can be mounted in the tuner cabinet or housed in a separate enclosure. If it is placed in the tuner cabinet, mount *S1* on the rear panel of the tuner and connect it to the pc board via low-capacitance shielded cable such as RG-59-U. The same type of cable should also be used to conduct the composite FM signal from the detector output to the input of the multiplex decoder.

If your tuner or receiver has a "composite FM" or "FM detector" output jack, the required signal is available there. If not, you will have to locate the FM detector and tap the signal at that point. The partial schematic of a typical FM receiver is shown in Fig. 4. The composite signal is obtained by disconnecting the existing multiplex decoder and tapping the signal at point A.

The left and right audio outputs are available at jacks *J3* and *J4*. If you are using the project in place of the multiplex decoder in a tuner, you can either use

these jacks in place of those in the tuner, assuming the decoder is mounted externally. If it is mounted internally, you can disconnect the outputs of the existing multiplex decoder from the output jacks on the tuner's rear panel and connect the outputs of the decoder's active filters.

Similarly, if you have a receiver and are mounting the project in an external enclosure, you can connect the decoder's outputs to the tape monitor circuit. Mounting the decoder inside the receiver cabinet suggests an internal connection. Remove the output leads at the ex-

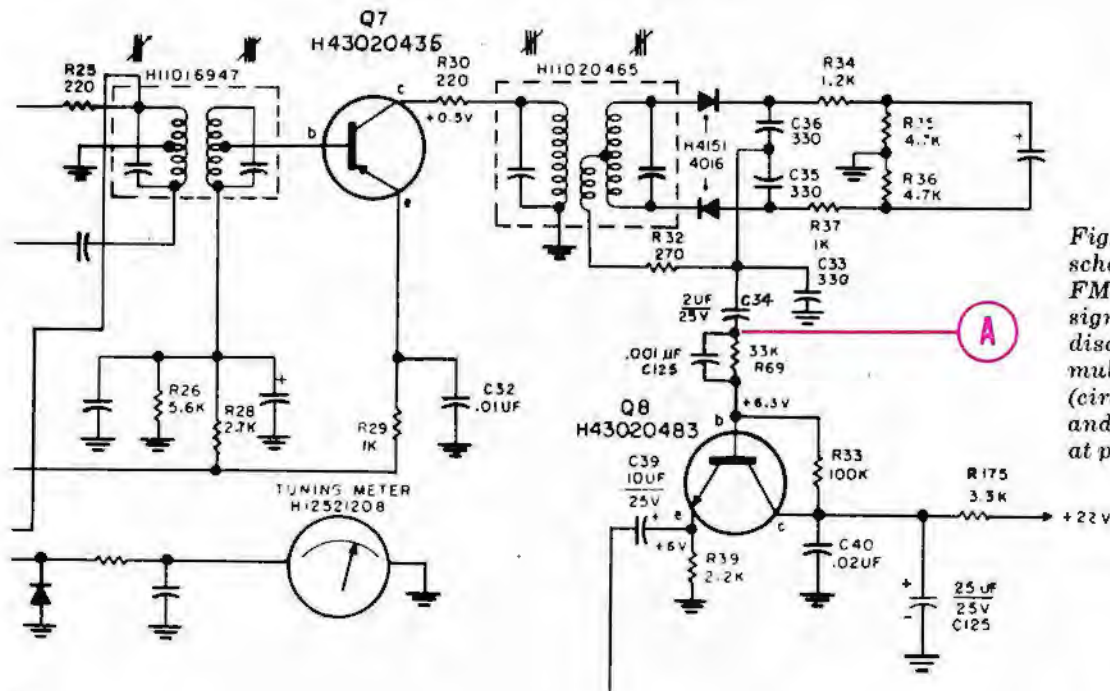

Fig. 4. Partial schematic of typical FM receiver. Composite signal is obtained by disconnecting existing multiplex decoder (circuit below *C34*) and tapping signal at point A.

isting multiplex decoder running to the appropriate lugs on the receiver's MODE switch. Then connect them to the decoder's active filter outputs.

Alignment. When properly aligned, the project will provide performance as outlined in Table I—assuming no degradation in the tuner's i-f and FM detector. Two typical receivers were used with the PLL decoder. Results are shown in Table II. The alignment procedure about to be described requires no test instruments, but will yield good results. The author was able to improve the stereo separation only 2 dB when instrument alignment was performed with an expensive FM stereo generator.

Rotate potentiometers *R1* and *R16* to the midpoint of wiper travel, and *R5* for maximum signal drive at the base of *Q1*. Turn on your receiver and tune in a station broadcasting in stereo. Indicator *I1* should glow. If not, adjust *R16* until it does. Then turn *R16* fully clockwise. If *I1* still glows, adjust *R5* until the indicator just goes out. Slowly rotate *R16* counter-

clockwise until the lamp begins to glow. Note the position of the control. (It may be necessary to adjust *R5* slightly.)

Next, turn *R16* fully counterclockwise, adjusting *R5* again if necessary to extinguish the lamp. Slowly rotate *R16* clockwise until the lamp glows, noting the position of the control. Set *R16* midway between the two positions noted. Adjust *R5* until the lamp goes dark, then slowly turn it until the lamp just starts to glow. Advance the wiper of *R5* another 10°. This will properly tailor the input level to decoder *IC1*.

Potentiometer *R1* is included in the circuit for adjustment if test equipment or

a cooperative FM broadcast engineer is available. Since all stations must conduct tests and certify the quality of their signals once a year, you can easily check out adjustments. Call several local stations and ask when they will perform the tests. If it is late at night, the engineer might turn off a channel for 30 seconds or so. While only one channel is being transmitted, adjust *R1* for maximum separation at any mid-band frequency. Note, however, the setting of *R1* will not have a critical effect on the performance of the decoder and can simply be left midway between the two adjustment extremes. ◇

TABLE II—RECEIVER MODIFICATION RESULTS

	Sony STR-6060FW		Harman Kardon SR900	
	Before	After	Before	After
Stereo Separation—100Hz:	20 dB	32 dB	25 dB	30 dB
1000 Hz:	28 dB	42 dB	32 dB	42 dB
10,000 Hz:	18 dB	30 dB	25 dB	33 dB
Total Harmonic Distortion (1000 Hz):	0.5%	0.3%	0.6%	0.25%

Quiz of Audio Basics

BY ROBERT P. BALIN

1 Which of these audio waveforms indicates the use of tremolo and which is vibrato?

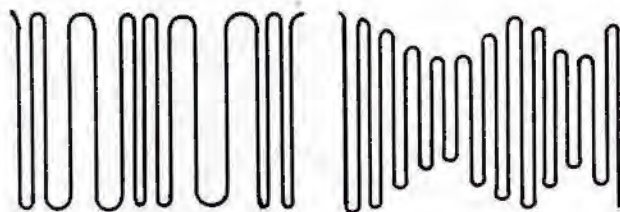

A

B

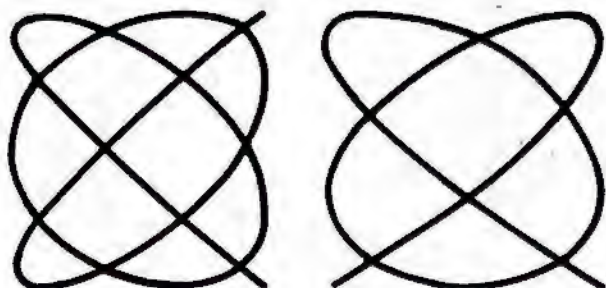

A

B

2 If the vertical frequency used to produce these Lissajous patterns is 1000 Hz, which has a horizontal frequency of 1200 Hz and which is 1250 Hz?

3 With this crossover network, which speaker is the woofer and which the tweeter?

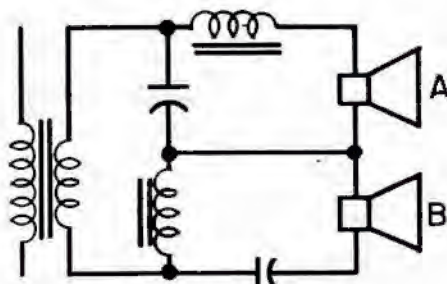

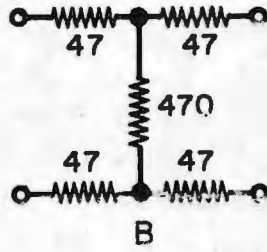
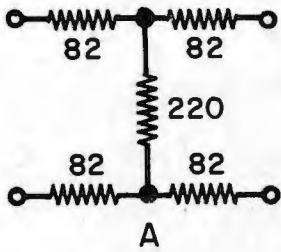

4 Of these 300-ohm attenuator pads, which produces a 6-dB signal voltage loss and which a 12-dB loss?



5 Which of these square-wave audio test signals indicates low-frequency attenuation and which high-frequency?

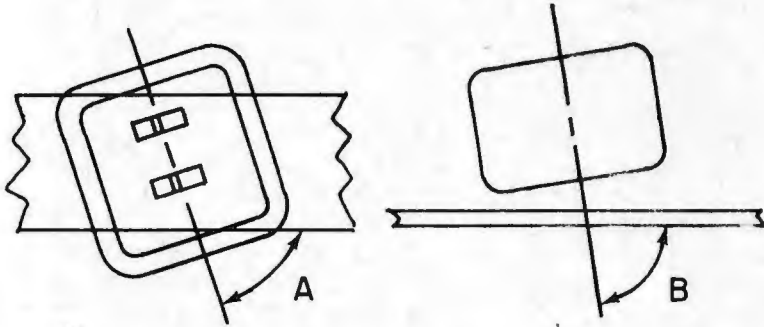

6 Which tape-head condition produces an azimuth error and which a zenith error?

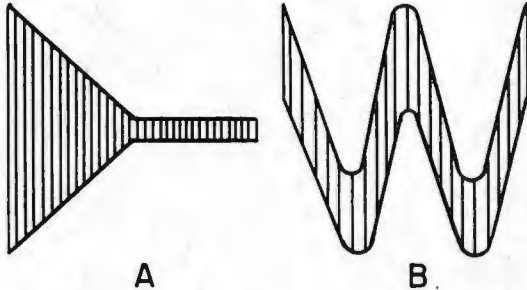

8 Which audio test signal has been affected by intermodulation and which by overmodulation?

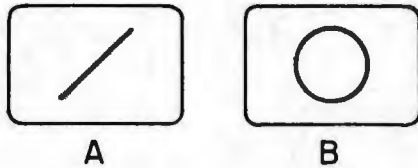

9 Which scope pattern indicates that two audio sine waves are in phase and which that they are 90° out of phase?

10 Which speaker baffle is known as a resonant column and which as an air coupler?

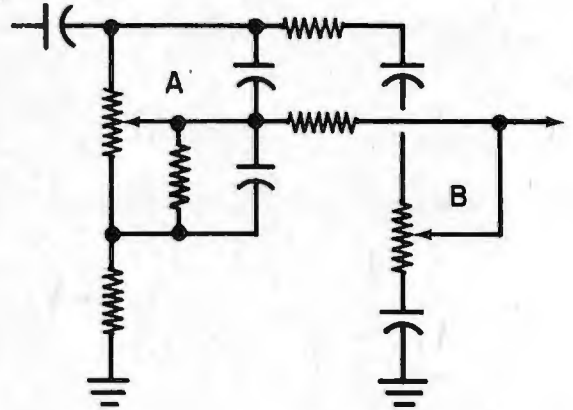

7 In this phono-amplifier tone control circuit, which pot is for treble and which is for bass?

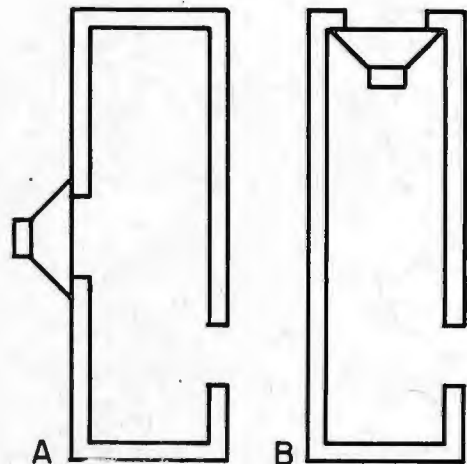

- ANSWERS
 1. Tremolo, B; vibrato A.
 2. 1200 Hz, A; 1250 Hz, B.
 3. Woofer, A; tweeter, B.

4. 6-dB, B; 12-dB, A.
 5. Low-frequency, A; high, B.
 6. Azimuth, A; Zenith, B.
 7. Treble, B; bass, A.
 8. Intermodulation, B; over, A.
 9. In phase, A; 90° out, B.
 10. Column, B; coupler, A.



Print Your Heart Out.

With help from the Digital Group, naturally.

Now, that small computer system you own or have been considering for personal or business use suddenly becomes a lot more usable—with the addition of a full-size *impact* printer from the Digital Group. A printer designed for small computers that need big output (like yours).

With the Digital Group printer, you can print your heart out...and it won't cost an arm and a leg. The Digital Group printer is available for less than \$500. That's right—\$500.

Just look at these specifications:

- Fast—120 characters per second
- 96 characters per line
- 12 characters per inch horizontal
- 6 lines per inch
- Makes up to 4 copies simultaneously
- Character set and pitch variable under software control—double width characters, etc.
- 5 x 7 character matrix
- Ribbon has built-in re-inkers for a life of 10,000,000 characters
- Paper can be either a standard 8½-inch roll, fanfold or cut page
- Interfaces to 8-bit parallel ports

There are lots of capabilities and outstanding features of the Digital Group printer...and (as always) the best news is our price. Kit prices start as low as \$495 for the printer and interface card. It simply can't be beat.

Find out all the facts about the Digital Group printer now. Just fill in the coupon below or give us a call for the details. We think you'll find a place for our printer in your system ...and in your heart.



P.O. Box 6528
 Denver, Colorado 80206
 (303) 777-7133

Quick. I want to print my heart out.
 Send me all the details on your full-size impact printer.

Name _____

Address _____

City/State/Zip _____

Please print.

FIRST WEST COAST COMPUTER FAIRE BY TOM MUNNECKE

SAN FRANCISCO was the setting last April for the First West Coast Computer Faire, which may become the Woodstock of the personal computing movement. Almost 13,000 people attended the 165 exhibits, 107 lectures, 17 home-brew demonstrations and two banquets.

The crowd was as kaleidoscopic as one would expect in San Francisco. Among them were a blind man seeking braille production equipment and voice synthesizers; Berkeley pamphleteers warning of government restrictions against home computers; artists looking for a new medium for artistic ex-

pression; and a father looking for aids for his deaf child.

Banquet speakers told of the coming revolution in home computing. Ted Nelson predicted that the "cybecrud" coming out of the large computers would be counteracted by the masses of personal computers. What used to be a topic for science fiction writers has come true, with the help of MPU's.

There were 37 conference sessions, covering everything from "Tutorials for the Computer Novice" to "Heretical Proposals." Commercial exhibitors had on display all their latest products, including electronic music synthesizers, speech

1



2



4



1 Prototype of Commodore's PET 2001, an "appliance-type" computer based on the 6502 MPU. Computer provides built-in BASIC, a graphics or character-oriented CRT, cassette storage, and 4k of RAM in a factory-assembled unit.

2 A portion of the exhibit hall, where 165 vendors displayed their wares to 12,750 people. The crowd and the size of the exhibition made it almost impossible to see all of the interesting computers on display.

3 Dr. Franz Frederick, Lafayette, Indiana, shows his "turtle" to Michael Rubinstein. Built in three weeks from surplus parts, it is controlled by a homebrew 6800 system to draw pictures while moving about the floor.

synthesizers and recognizers, and 64k memory boards.

A new class of computers emerged at the Faire—the so-called appliance computer. Meant to be purchased much as one would buy a television receiver or stereo tuner, these computers are complete systems that require no assembly. Apple Computers, Inc., showed the Apple II, a 10-lb (4.5-kg) microcomputer with keyboard, color-TV and audio cassette interfaces, game paddle, and BASIC built-in for \$1300. Commodore International had a working prototype of its PET 2001 computer, which has a CRT, keyboard, cassette drive, IEEE 488 interface, and built-in BASIC; price goal is the \$500-\$600 range. Commodore sees the personal computing market as a

merger of the electronic games and calculator markets and expects the same dramatic decline in prices as more of the semiconductor manufacturers join in the competition.

There was a general air of amazement at both the number and sophistication of the products offered by the vendors. Since the January, 1975 POPULAR ELECTRONICS article introducing the Altair 8800 microcomputer, a dozen new companies have emerged to offer Altair-compatible mainframes; memory boards have increased 16 times in capacity; an array of compatible peripherals is being offered; and a whole new generation of computers has emerged. And all those people came to San Francisco to see it happen. ◇



3

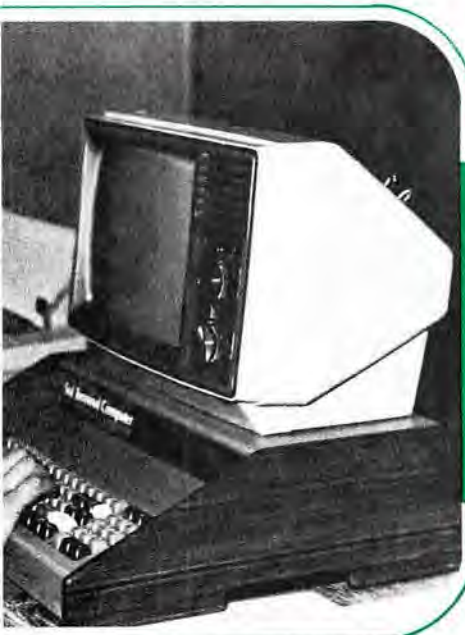

5



6

4 Angela and Joanna Prelesnik, of Santa Clara, react to the PET's showing of their lunar landing module's crash on the moon. MOS Technology 6502 architect Chuck Peddle is shown looking on at left.

5 Dennis Wong, from Mountain View, shows his computer-based payroll system for small businesses. System consists of a Processor Tech. SQL microcomputer, a North Star Floppy Disk, and Memorex printer, all for less than \$3000.

6 Rich Gold's "Mr. Computer" is based on a KIM-1 and 200-byte program. Its coded messages (via LED displays in its mouth) are interpreted by Rich in storybook form. He plans to add video graphics and electronic music output.



BUILD "Cabonga"

PART 2

How to use various accessories to achieve greater flexibility.

BY JAMES BARBARELLO

LAST MONTH, we described the circuitry and construction of the Cabonga electronic percussion synthesizer. Now here are four accessories—the Snare Drum Adapter, the Auto Trigger, the Sound Modifier, and the Combiner/Power Pack. Methods of interconnecting them with each other and the Cabonga will be shown. The result of these patches will be a flexible and expandable percussion synthesizer system.

The Cabonga has two jacks which, until now, you have not used. They are marked EXTERNAL TRIGGER and EXTERNAL POWER. The EXTERNAL TRIGGER jack will be used with the Auto Trigger and the Snare. The EXTERNAL POWER jack will accept ± 9 volts from the Combiner/Power Pack. Actually, all Cabonga system components could be powered by 9-volt batteries. Cost, however, makes this an unattractive proposition in a multi-component system.

The Combiner/Power Pack will not only provide ± 9 volts dc (if 117 volts ac is available), but also includes a unity-gain active mixer. This mixer will sum up to five input signals and present them at a low-impedance output. In practice, all Cabonga components will operate with supplies ranging from ± 8 to ± 15 volts dc. Accordingly, the Combiner/Power Pack does not include such features as voltage regulation, foldback current limiting, etc. If you're a purist, you can add them; but you will probably not be able to hear any difference.

The schematic of the Combiner/Power Pack is shown in Fig. 6. A full-wave bridge composed of *D1* through *D4* rectifies ac from *T1*, a 12.6-volt, 1.2-ampere center-tapped transformer. Pulsating dc produced by the bridge is filtered by

electrolytic capacitors *C1* and *C2*. The ± 9 -volt output of the power supply is routed to jacks *J1* through *J6* and to *IC1*, the unity-gain summing amplifier.

Etching and drilling and parts placement guides are shown in Fig. 7. Be sure to observe polarities and pin basing

of semiconductors and electrolytic capacitors. The Combiner/Power Pack should be housed in an enclosure measuring about $9\frac{1}{4} \times 4 \times 2\frac{1}{2}$ ($23.5 \times 10.2 \times 6.4$ cm). The top and bottom of each wall should be rabbeted to provide a $\frac{3}{8}$ " (9.5-mm) deep $\times \frac{1}{4}$ " (6.4-cm)

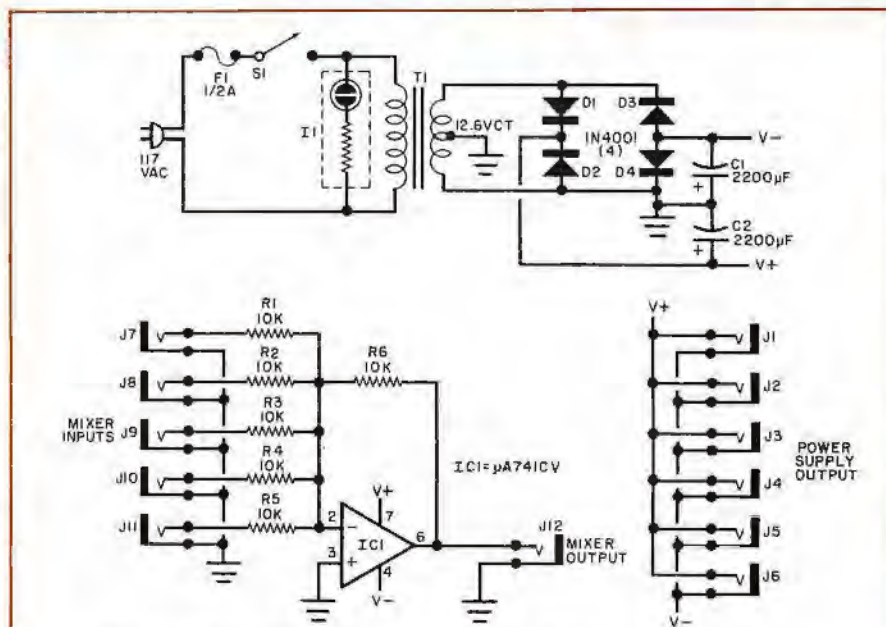

COMBINER/POWER PACK PARTS LIST

- C1, C2—2200- μ F, 16-V electrolytic capacitor
- D1 through D4—1N4001 silicon diode
- F1— $\frac{1}{2}$ -ampere fuse
- I1—120-V ac neon pilot lamp assembly (Radio Shack 272-703 or equivalent)
- IC1— μ A 741CV operational amplifier
- J1 through J6—Miniature phone jack
- J7 through J12—Standard phone jack
- R1 through R6—10,000-ohm, $\frac{1}{4}$ -watt, 10% carbon composition resistor
- S1—SPST switch
- T1—12.6-V, 1.2-A transformer
- Misc.—Printed circuit board, ac line cord, etc. See photo p. 80 for kit prices.

Fig. 6. Schematic of Combiner/Power Pack. The former is a full-wave rectifier with filters.

BILL OF MATERIALS

- 1—Piece $\frac{1}{32}$ " aluminum $8\frac{3}{4} \times 2-15/16$ "
- 1—Piece $\frac{1}{16}$ " phenolic stock $1\frac{3}{4} \times 1\frac{1}{4}$ "
- 2—Pieces $\frac{3}{4}$ " pine or plywood $9\frac{1}{2} \times 2\frac{1}{2}$ "
- 2—Pieces $\frac{3}{4}$ " pine or plywood $3-1/16 \times 2\frac{1}{2}$ "
- 1—Piece $\frac{1}{4}$ " plywood $8-7/16 \times 3$ "
- 1—Piece $\frac{1}{8}$ " rubber matting $8-7/16 \times 3$ "
- 1—Piece black vinyl 28×5 "
- 10—No. 4 $\times \frac{1}{2}$ " sheet metal screws
- 1— $\frac{3}{8}$ " grommet
- Misc.—Contact cement, etc.

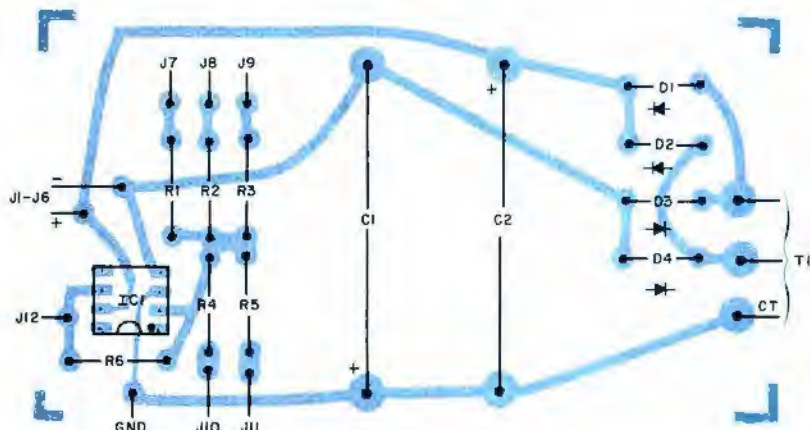
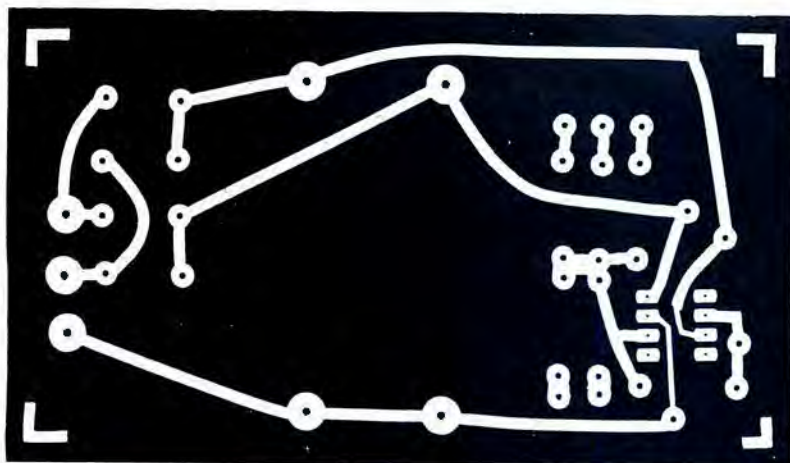

Fig. 7. Guides for Combiner/Power Pack board.

"shelf" on which to mount the top and bottom plates. This will enable the plates to be flush with the top and bottom of the walls. Round all top and bottom edges of the walls with sandpaper.

Form a top plate from an $8\frac{3}{8} \times 2\text{-}15/16$ " (21.3- \times 7.5-cm) piece of $1/32$ " (0.8-mm) aluminum stock. Holes should be drilled for the mixer input and output and power output jacks, for the line cord, power switch and pilot light. The power output jacks, as well as the EXTERNAL POWER jacks on the Cabonga components, must be isolated from the aluminum top plates. This is because the "ground" portions of the jacks are at -9 volts. Isolation can be ensured by drilling the holes for the jacks with $7/16$ " (1.1-cm) bits. The jacks should be mounted on a $1\frac{3}{4} \times 1\frac{1}{4}$ " (4.4- \times 3.2-cm) piece of $1/16$ " (1.6-mm) phenolic.

An $8\text{-}7/16 \times 3$ " (21.4- \times 7.6-cm) piece of $1/4$ " (6.4-mm) plywood forms the bottom plate. If you wish, you can fashion a sheet of ribbed rubber runner to the outer surface of the bottom plate with contact cement. The runner will provide an antiskid surface for the Combiner/Power Pack. The case can be covered with a 28×5 " (71.1- \times 12.7-cm) piece of black vinyl. Secure the vinyl to the case with contact cement by wrapping it around the perimeter. At each

corner, slit the vinyl and trim it as necessary. Carefully fold the vinyl over the top and bottom edges and into the rabbets.

Wire the jacks, switch, etc., according to the schematic diagram. When all connections have been made, secure T1 and the pc board to the bottom plate, and the top and bottom plates to the case. Make one patch cord from a convenient length of shielded audio cable, terminating its ends with miniature phone plugs and prepare one patch cord terminated with standard phone plugs for each Cabonga. Also make one terminated with miniature phone plugs and one terminated with subminiature phone plugs for each Auto Trigger or Snare.

To test the Combiner/Power Pack, plug one power patch cord (terminated with miniature phone plugs) into a power output jack. Then connect the line cord

to a wall socket and close S1. Indicator I1 should glow. Attach the negative probe of a voltmeter to the barrel of the miniature phone plug, and the positive probe to the plug tip. The meter should read 17 to 20 volts dc. If you read only half of this voltage or zero volts, turn off the Combiner/Power Pack and disassemble the enclosure. Check your wiring for shorts. When the reading is correct, attach the negative probe to the aluminum top plate and the positive probe to the plug tip. A reading of 8.5 to 10 volts dc should be obtained.

Turn off the power by opening S1. Then remove the patch cord from the power plug. As the plug barrel comes out of the jack, it momentarily touches both terminals of the jack and shorts them together. The Combiner/Power Pack's supply can take a direct short for a second or two without damage to its components. As a rule, however, you should turn off the power before making any power patch cord changes.

Connect a Cabonga to the power supply and mixer circuits to verify that both are functioning correctly. Successively try each power and mixer input jack to be sure they are correctly wired.

The Modifier. Most often, the damped sinusoidal output of the Cabonga is the signal you will use. But there will be times when a certain amount of clipping is needed. For example, the peaks of the Cabonga output should be clipped somewhat to get a "crisp" sound like that of a good bongo. This also produces a better sounding tom-tom.

The schematic diagram of the Modifier is shown in Fig. 8. The circuit is simply a 100-ohm potentiometer. It presents a variable load of from 0 to 100 ohms to the output stage of the Cabonga. As the load resistance decreases below the value required for "crispness," various sound effects can be obtained. Although the load resistance as seen by the Cabonga varies, the Combiner/Power Pack input sees a constant 100-ohm signal voltage source.

The Modifier, as well as the Auto Trig-

Fig. 8. Modifier is simple potentiometer circuit shown here.

MODIFIER PARTS LIST

J1, J2—Standard phone jacks
R1—100-ohm, linear-taper potentiometer
Note—See photo p. 80 for kit price.

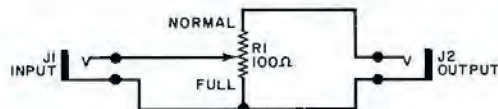

BILL OF MATERIALS

Same as for Auto Trigger, less phenolic stock and one $3/4$ " diameter knob.

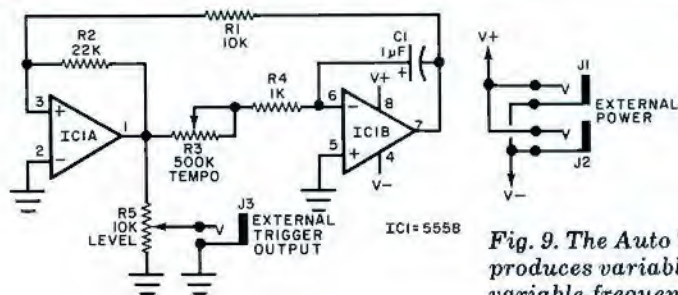

AUTO TRIGGER PARTS LIST

- C1—1- μ F, 16-volt electrolytic capacitor
- IC1—5558 dual operational amplifier
- J1, J2—Miniature phone jack
- J3—Subminiature phone jack
- R1—10,000-ohm, 1/4-watt, 10% carbon composition resistor
- R2—22,000 ohm, 1/4-watt, 10% carbon composition resistor
- R3—500,000-ohm, audio-taper potentiometer
- R4—1000-ohm, 1/4-watt, 10% carbon composition resistor
- R5—10,000-ohm, linear-taper potentiometer

Misc.—Printed circuit board, hookup wire, etc. See photo p. 80 for kit prices.

BILL OF MATERIALS

- 1—Piece 1/32" aluminum 4" x 2"
- 2—Pieces 3/4" pine or plywood 5-1/16" x 2"
- 2—Pieces 3/4" pine or plywood 2-1/16" x 2"
- 1—Piece 1/8" rubber matting 4-3/4" x 2-3/4"
- 1—Piece 1/16" phenolic stock 1 1/2" x 1/2"
- 1—Piece black vinyl 16 1/2" x 3 1/2"
- 4—No. 4 x 1/2" sheet metal screws
- 2—3/4" diameter knobs

Fig. 9. The Auto Trigger produces variable-level, variable-frequency square waves.

ger and Snare, should be housed in enclosures measuring about 5 1/4" x 3 1/8" x 2" (13.4 x 7.9 x 5.1 cm). The enclosures should be constructed from the same materials as used for the Cabonga itself and the Combiner/Power Pack, rabbeted, and finished with black vinyl and rubber matting. Top plates can be made from 4" x 2" (10.2- x 5.1-cm) pieces of 1/32" (0.8-mm) aluminum stock. Two standard phone jacks and the 100-ohm potentiometer are mounted on the Modifier top plate. Wire them as per Fig. 8.

To test the Modifier, patch the output of the Cabonga to input jack J1, and the output of the Modifier (J2) to the mixer input of the Combiner/Power Pack. Place R1 in its NORMAL position. Play the Cabonga and slowly rotate R1 toward its FULL position. You will notice that the sound becomes "crisp." As the control is rotated further, the sound will become more and more distorted and lower in volume. At the extremity of wiper travel, the output will be a steady oscillation if your potentiometer's minimum resistance closely approaches zero ohm. (This will not damage the Cabonga output state.)

The Auto Trigger. Before we discuss the Auto Trigger, let's review how the Cabonga has been triggered until now. When the head is struck, switch S1 closes and applies a pulse to the active filter, resulting in a damped sinusoidal output. The amplitude of the trigger pulse determines the amplitude of the output signal. Jack J1 (EXTERNAL TRIGGER) is connected in parallel with S1 so

that an external pulse source can cause the generation of a percussive output.

The Auto Trigger is such a pulse source. It produces a variable level (0 to 9 volts), variable-frequency (0.5-to-400-Hz) square waves. Its circuit, shown schematically in Fig. 9, is not complicated. Only seven components are used. Operational amplifier IC1A, one half of a 5558 dual op amp IC, is used as a comparator. The other half, IC1B, is used as an integrator. When the comparator output changes states, a pulse is generated. This pulse is integrated by IC1B into a ramp whose slope depends on the amount of signal current supplied to the integrator, and thus on the values of R3 and R4. When the output of the integrator reaches one-half of the supply voltage, the comparator changes states again. The process then repeats itself.

Resistors R3 and R4, and capacitor C1 determine the frequency of oscillation. It can be varied over a wide range by adjusting TEMPO control R3. The upper limit of oscillation is governed by R4. Square waves appear at the output of IC1A and are coupled to J3 by LEVEL control R5. Power is derived from the Combiner/Power Pack and coupled to J1 or J2. An extra power jack is provided for patching to other accessories.

Etching and drilling and parts placement guides for a suitable schematic are shown in Fig. 10. Be sure to observe the polarity of C1 and the pin basing of IC1 when mounting them on the board. Construct an enclosure and top plate to the dimensions and style previously described. Note that jacks J1 and J2 must

be isolated from the aluminum top plate, which is at ground potential.

Connect a power patch cord between the Combiner/Power Pack and J1 or J2 of the Auto Trigger. Then connect a patch cord terminated with subminiature phone plugs between the Cabonga's EXTERNAL TRIGGER jack (J1) and the Auto Trigger output (J3). Turn the Auto Trigger's TEMPO and LEVEL controls fully clockwise. Then close the Combiner/Power Pack's power switch and monitor the mixer output. You will hear an output signal about once every two seconds. As the TEMPO control is rotated, the trigger rate will increase. Rotating the LEVEL control will vary the output signal's volume from minimum to maximum.

The Snare Drum Adapter. The snare sound is the most difficult to synthesize because a snare drum produces three different sounds simultaneously. As the drumstick strikes the top head, the sharp sound of the strike is heard. At the same time the sound of the drum itself (actually a medium-size tom-tom) is produced. The bottom head also vibrates and causes the snare wires touching it to move.

We can synthesize this complex sound by combining three different components: a high-level, short-duration pulse; an exponentially damped sine wave; and filtered noise. The damped sinusoid is already available at the Cabonga to trigger an accessory that

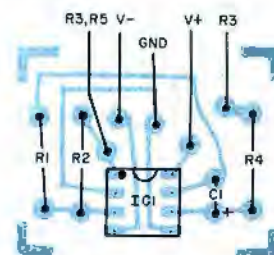
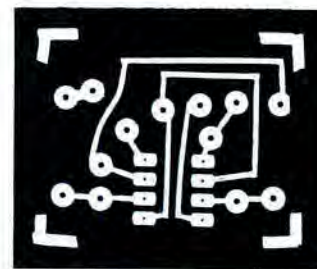

Fig. 10. Guides for Auto Trigger board.

will produce the other two components and mix them all together to produce a synthesized snare.

That is exactly what the Snare Drum

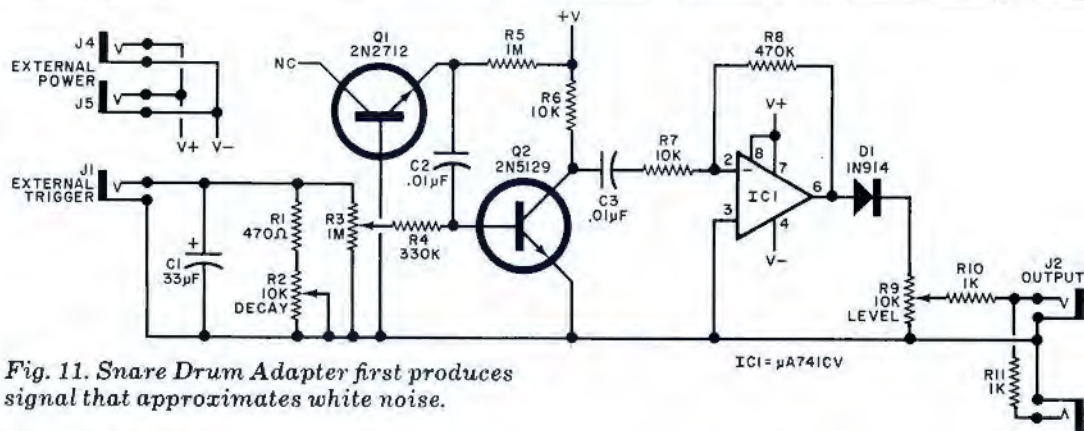

Fig. 11. Snare Drum Adapter first produces signal that approximates white noise.

SNARE DRUM ADAPTER PARTS LIST

C1—33- μ F, 16-volt electrolytic capacitor
 C2, C3—0.01- μ F disc ceramic capacitor
 D1—1N914 or 1N4148 silicon diode
 IC1— μ A 741CV operational amplifier
 J1—Subminiature phone jack
 J2, J3—Standard phone jack
 J4, J5—Miniature phone jack

Q1—2N2712 npn silicon transistor
 Q2—2N5129 npn silicon transistor
 The following fixed resistors are 1/4-watt, 10% carbon composition components.
 R1—470 ohms
 R4—330,000 ohms
 R5—1 megohm
 R6, R7—10,000 ohms
 R8—470,000 ohms

R10, R11—1000 ohms
 R2, R9—10,000-ohm, linear-taper potentiometer
 R3—1-megohm trimmer potentiometer
 Misc.—Hookup wire, printed circuit board, etc. See photo p. 80 for kit prices.

BILL OF MATERIALS

Same as for the Auto Trigger

Adapter does. It is shown schematically in Fig. 11. Noise generator $Q1$ produces a continuous signal that approximates white noise. Capacitor $C2$ couples this noise to the base of $Q2$.

When a voltage spike is applied to the Snare's EXTERNAL TRIGGER jack ($J1$), it charges $C1$. Such a spike is available when the Cabonga's trigger switch closes as the head is struck. Depending on the values of $R1$ and $R2$, the voltage across $R3$ decays exponentially with a time constant equal to the product of $C1$ and $(R1+R2)$. A portion of this voltage envelope (determined by the setting of $R3$) is also applied to the base of $Q2$ via

$R4$. The voltage envelope causes $Q2$ to conduct and pass the noise signal.

Transistor $Q2$'s output is filtered and capacitively coupled by $C3$ to a high-gain amplifier. At the input to op amp $IC1$, the signal comprises a high-level spike and a very low-level noise component. Amplifying the signal by a factor of 47 (determined by the ratio $R8/R7$) produces a useful effect. The initial spike, whose amplitude is already approaching the positive supply voltage, is relatively unaltered while the noise component is amplified and equalized in level with the spike.

However, the high gain has an unde-

sirable side effect—it greatly accentuates the internal noise of the inexpensive op amp. To eliminate this noise, $D1$ is placed in series with the op amp output. The diode will not pass signals below 0.7 volt, so the unwanted noise, which would sound like a low-level hiss, is eliminated but the desired signal is allowed to pass. In the process, we get a bonus—the noise is made to sound more realistic by clipping off its bottom half. Resistors $R10$ and $R11$ combine the Cabonga and Snare waveforms into a single output, available at output jack $J2$. Potentiometer $R9$ serves as a LEVEL control for the snare signal.

Etching and drilling and component placement guides are shown in Fig. 12. Mount the components on the board, observing polarities and pin basing of the semiconductors and electrolytic capacitors. Construct an enclosure and top plate to the dimensions and style previously described. Note that jacks $J4$ and $J5$ must be isolated from the aluminum top plate, which is at ground potential. Trimmer potentiometer $R3$ is installed on the pc board. The other potentiometers are mounted on the top plate.

Patch external power to $J4$ or $J5$, and run patch cords from the Cabonga output and external trigger jacks to $J3$ and $J1$, respectively. Interconnect the Snare

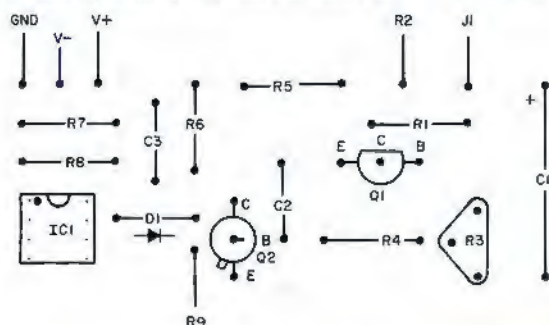

Fig. 12. Use the etching and drilling guide below and component placement at left to make Snare Drum Adapter board.

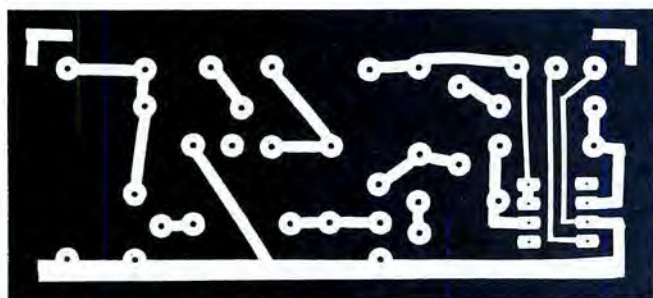

Fig. 13. Simple circuit to trigger Snare.



output (J2) to the Combiner/Power Pack's mixer input. Place the thumbwheel of R3 at the midpoint of its rotation. While striking the Cabonga drum head, adjust the setting of R3 in either direction until you obtain the most pleasing sound. As you strike the head, you will hear the sound of the strike, the tom-tom and the noise simultaneously. The relative loudness of the strike sound as compared to the noise is governed by R3, so you might have to make a compromise adjustment of the trimmer potentiometer. Adjust the output level to obtain a balanced snare sound.

Use the circuit shown in the Fig. 13 to trigger the Snare. It will result in a fair approximation of a cymbal. Then trigger the Snare with the Auto Trigger. For a different effect, prepare a patch cord from a single piece of stranded hookup wire. Solder the hookup wire to the tips of two subminiature phone plugs. Connect the patch cord to the Auto Trigger output and the Snare EXTERNAL TRIGGER input. Turn both Snare controls to maximum. By adjusting the Auto Trigger TEMPO and LEVEL controls, you can create such effects as the sound produced by a biplane.

Using the Cabonga System. The Cabonga and its accessories form an expandable synthesizer system. As with any electronic musical instrument, the best way to realize its full potential is to experiment. Here are some hints. It is always best to turn off the power before making any patch cord changes. As previously mentioned, this prevents inadvertent damage to the power supply diodes. It's the only restriction on use of the system that should be observed. Let your imagination dictate system configurations and patches.

Cabonga accessories are shown here and below. Following are available from JAL Assoc., Box 107, Eatontown, NJ 07724: Combiner/P-P pc board at \$3.50, complete kit, \$27; Snare pc board, \$3.50, complete kit, \$16.95; Auto Trig. pc board, \$1.50, complete kit, \$12.95; Modifier complete kit, \$7.50. All postpaid. NJ residents add 5% sales tax.

A three-head system is shown in Fig. 14. (You may prefer a fivehead system.) Cabonga 1 is set up as a snare, Cabonga 2 as a tom-tom and Cabonga 3 as an automated bass drum, resulting in an electronic drum set. Set the Modifier control to give a crisp tom-tom sound.

The Controller and Power Pak is necessary to connect all the other units together.

As mentioned in Part I of this article, the Cabongas can be interconnected via their EXTERNAL TRIGGER jacks. Tune two Cabongas an octave apart and interconnect them. You will note that the sound produced is much fuller than that from just one. Another possibility using four Cabongas is as follows. Tune two (A and B) as a Conga set and two (C and D) as a pair of Bongos. Interconnect A to

C and B to D. When you play either the Congas or Bongos, you'll hear both pairs simultaneously.

The Auto Trigger can be used in many different ways. Adjust its output frequency for about 2 Hz and use it to trigger the Cabonga. Briskly rotating the Cabonga PITCH control back and forth will produce an effect reminiscent of the "musical percolator" that appeared in television coffee commercials.

By increasing the tempo and rotating the PITCH control from minimum to maximum, you'll hear a sound effect common to science fiction movies. If the tempo is set just right, you will hear an "echo" as the bubbling sound increases in pitch. Stepping up the tempo even more causes the sound to become a continuous oscillation. The Cabonga then acts like a variable bandpass filter (waa waa), and the PITCH control functions as the bandpass frequency selector. You can also trigger the Snare with the Auto Trigger to create such sounds as that from a locomotive, breathing, and others which are difficult to describe!



On the more practical side, you can use a number of Cabongas and Modifiers to make a fairly realistic steel drum set. The Modifier, as previously mentioned, is most useful when synthesizing a Bongo or tom-tom.

Those are some ideas to get you started. As you experiment more and more, you will probably create sounds that no one else has even thought of! ◇

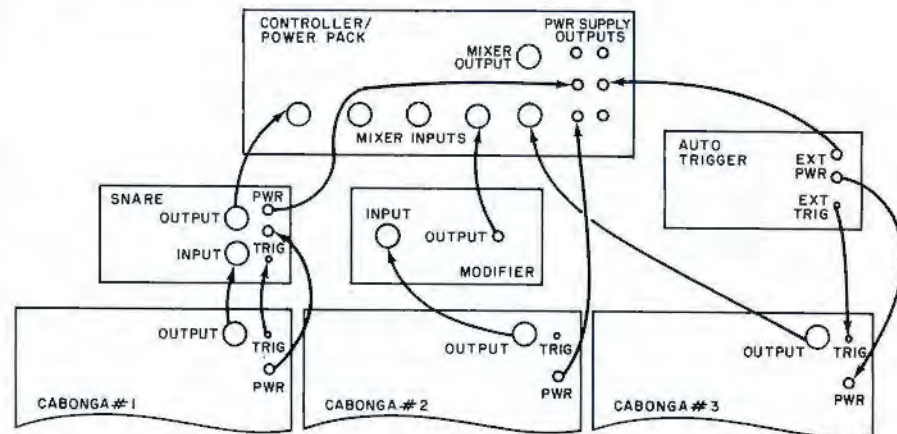

Fig. 14. This interconnection diagram shows how to set up a three-headed Cabonga system.



HOW TO CUSTOM DESIGN PLASTIC CASES FOR PROJECTS

BY JOHN HUFF

An auto-clock case is used to describe cutting, bending, joining, etc.

YOUR electronic projects deserve to be housed in attractive and reasonably priced "custom designed" cases. As a modern hobbyist, you don't have to make do with utility boxes that do not complement your projects. Instead, you can design your own inexpensive and attractive plastic cases, thanks to the ready availability of acrylic plastic sheets and tubes.

Acrylic plastic is easier to work with than wood—and with the same tools used in woodworking. It can be cut, filed, sanded, glued, and even bent to permanently conform to a desired shape. Available under such brand names as Plexiglas, Lucite, and Safe-t Vue, it comes in crystal clear, color-tinted transparent, translucent, and opaque sheets in 1/16", 1/8", and 1/4" (1.6, 3.2, and 6.4 mm) thicknesses.

This article describes how to work with acrylic plastic to custom design and fabricate cases for your electronic projects. To illustrate the step-by-step procedure to use, we also include a digital Kar Klok project to assemble (see box). The Kar Klok is built around National Semiconductor's new MA1003 clock module, a printed circuit assembly containing a four-digit 0.3" (7.6-mm) high fluorescent display, time base, clock chip, and all necessary driving circuitry.

Working With Acrylic. Just about any brand of acrylic plastic can be used by the electronics hobbyist because all

have the same basic physical properties. However, some types of acrylic are easier to work with than are others. Most acrylic pieces made by the cast method can be cemented together with a solvent that actually dissolves the mating surfaces and forms a monolithic weld joint in minutes. More difficult to work with are the acrylics made by a continuous conveyor-belt process, which require a

thickened type of cement (airplane dope) that takes an hour or more to set. Needless to say, cast acrylic, such as Plexiglas G, is your best first choice. Ask for Plexiglas G (or similar cast-type acrylic) at your local hardware or hobby/craft store.

Acrylic sheets come with a special protective paper on both surfaces to prevent scratches. This paper makes an ex-

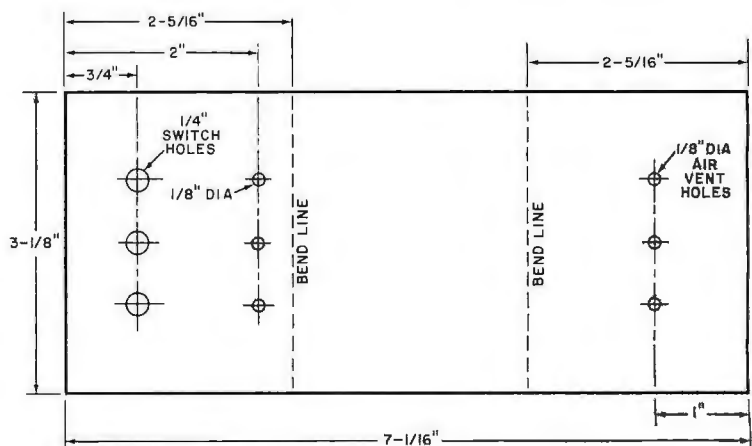
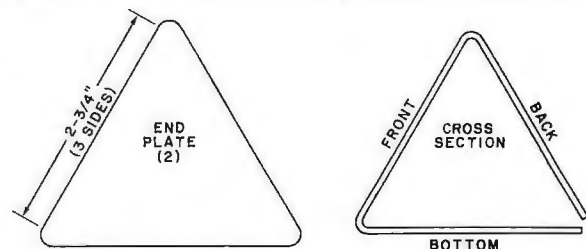

Fig. 1. Fabrication details for the Kar Klok case.



ALL PIECES—1/16" ACRYLIC PLASTIC

cellent surface for marking cutting lines and the centers of holes to be drilled.

The plastic can be cut with a saw or a special scribing tool. You can use a jigsaw, hacksaw, coping saw, or saber saw for cutting. However, scribing is easier if all you have to do is cut straight lines. Curved lines and circles still require cutting with a saw.

The fabrication details for the Kar Klok (see box) case are shown in Fig. 1. Mark all necessary lines and hole centers on the protective paper on the acrylic sheet.

The scribing tool, which sells for about \$2.00 wherever the plastic is sold, looks like a miniature harpoon. In use, the sharp point of the tool is guided along the cut line with moderate downward pressure, using a straight edge, as shown in Fig. 2. Once the line is scribed, the plastic is placed over the edge of a table, scribed line up and in direct alignment with the edge of the table, and struck sharply on the side overhanging the table. The snapping action yields a very straight, clean edge. The snapped edges must then be lightly smoothed with fine sandpaper before being cemented. Edges that are not to be cemented can be buffed to a crystal sheen with a drill-mounted muslin wheel and a special buffing compound (about \$3.00 for wheel and compound) or with fine steel wool and soap and water.

Cutting holes is done with ordinary drill bits, as shown in Fig. 3. It is important to note that during the drilling operation, the sheet of plastic must be firmly held or clamped to a piece of wood to prevent it from riding up the bit and cracking. Square and rectangular slots can be made by drilling a small hole and cutting with a coping saw.

Since the Kar Klok case pictured in the lead photo and dimensioned in Fig. 1 is triangular in shape, it is necessary to bend the acrylic plastic sheet to conform to this shape. The trick to making accurate bends is to use a bending jig and heat only those portions of the plastic that are to be bent. Do not heat the entire surface of the plastic.

Acrylic plastic bends at about 300° F (about 150° C). It bends best if the protective paper is peeled off before the heat is applied. You can heat the plastic along the bend line in several ways, the easiest of which is to use the specially made strip heater element that sells for about \$8.00 from the same dealers who handle the plastic. This heater element requires a simple wood strip that keeps it about 1/4" (6.4 mm) away from the plastic. Detailed instructions come with the element.



Fig. 2



Fig. 3



Fig. 4

Fig. 2. The acrylic scribing tool, obtainable wherever the plastic is sold, looks like a small harpoon and is used to scribe a line, following a straight edge, where the plastic is to be broken.

Fig. 3 Acrylic is easily drilled by holding the plastic firmly to a wooden base. Here, holes are being drilled for pushbutton switches. Square and rectangular slots can be made by drilling a hole and cutting with a coping saw.

Fig. 4. Acrylic bends at about 300° F. Here strips of wood faced with cloth for protection, are placed on both sides of bend mark and heat is applied by a 1000-watt hair dryer.

Fig. 5. Heat for bending can also be obtained from a 500-watt photoflood bulb.

Fig. 6. Once the plastic has been heated, it can be bent using a jig as shown here. Note that the actual crosssection of the case has been drawn on the bottom of the jig. Jig corners are 4-inch nails.

Fig. 7. Acrylic solvent cement is easily applied and dries in minutes. Here one end of the clock case is being glued to the main frame.

Fig. 8. If preferred, an acrylic cylinder can be used for the body of the clock with square end pieces as shown here.



Fig. 5

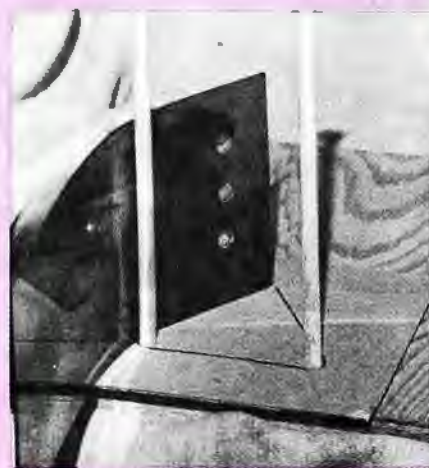
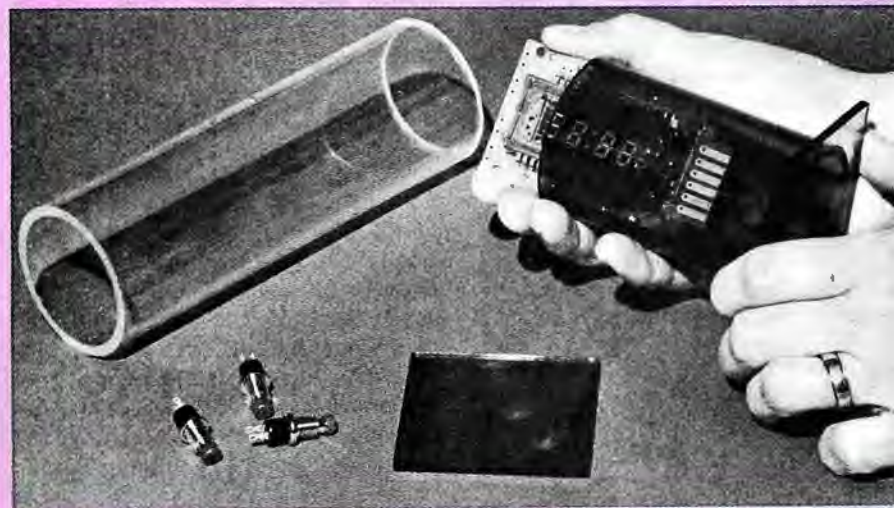

Fig. 6



Fig. 7

Fig. 8



Another bending technique is to place the plastic sheet on a flat surface, place a 1/4" thick strip of wood on both sides of the bend line (face the strips with soft cloth or cotton to prevent them from scratching the plastic), and use a blow-type hair dryer to heat along the line. Details are shown in Fig. 4. The hair dryer must be rated at a minimum of 1000 watts. How well it heats the plastic depends on the chemistry of the particular sheet of acrylic you use. Do not hold the dryer too close to the plastic or the air flow will be restricted and the heat fuse will blow.

Still another approach that works for heating the plastic is to use a 500-watt photoflood lamp. Again, use wood strips to frame the bend line. Hold the plastic about 10" (25.4 cm) away from the lamp as shown in Fig. 5.

Once the plastic has been heated, it can be bent to shape using a bending jig as shown in Fig. 6. Note here that, to get the angles correct during bending, the actual-size crosssection of the body of the clock case is drawn on the base of the jig. A 4" (10.2-cm) long nail is then driven into the indicated corners of the drawing and the plastic is aligned with the drawing and gently bent around the nails. When the bending operation is complete, there will be a small open slot where the ends of the plastic sheet do not quite meet. This slot is used for running the wires between the vehicle's electrical system and the clock module, without drilling holes.

Next, cut the triangular end pieces for the case from the same plastic sheet from which the case body was cut, using Fig. 1 as a guide. After sanding the edges smooth and buffing them, cement one side piece to the case body as shown in Fig. 7. Slip the clock module into the case. Then fasten down the pushbutton switches in their appropriate holes and route the electrical-system hookup wires through the slot in the body of the case. Cement the other side piece to the case.

Decide where in your vehicle you want to mount the Kar Klok and cement Velcro strips to the bottom edges of the case end pieces with the solvent cement and to the dashboard with a silicone adhesive. Finally, route the wires coming from the clock module into your vehicle's electrical system (see box for hookup details). The use of Velcro strips to mount the clock allows you to remove the clock and put it out of sight to reduce the possibility of theft.

A Simpler Case. Perhaps you do not

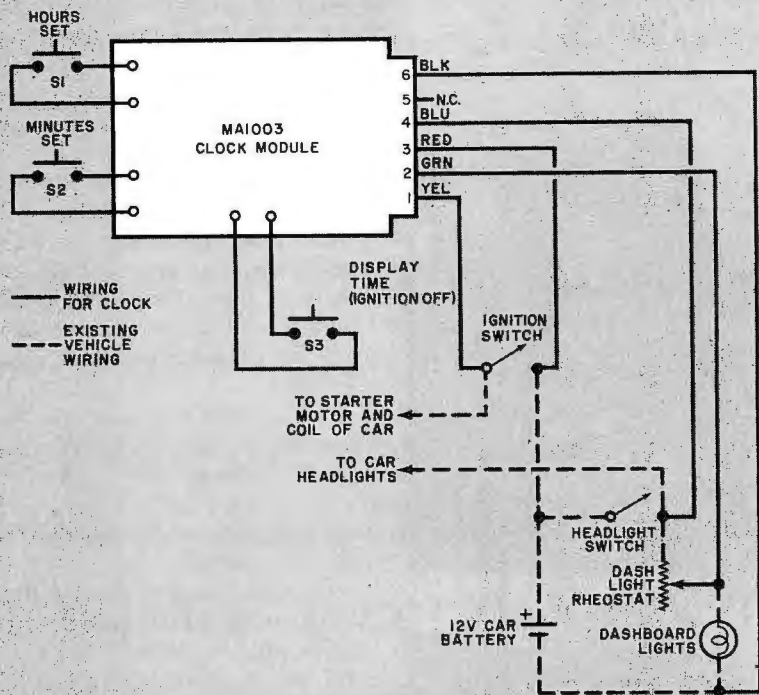

ABOUT THE CLOCK

As shown in the schematic diagram, the Kar Klok is a very simple project to put together. It is built around National Semiconductor's new MA1003 clock module that requires the addition of only three momentary-action pushbutton switches and five wires to be connected into the vehicle's electrical system.

With the Kar Klok wired as shown, the display will be on continuously as long as the vehicle in which it is installed is running. The clock remains powered even with the ignition turned off, but power is removed from the display to conserve battery power. However, even with the ignition off, the time can be displayed on demand simply by pressing switch S3.

Switches S1 and S2 provide the means for setting the hours and minutes for the correct time. These switches are activated only when the ignition is on. With the ignition turned off, the time-setting switches are disabled.

Basically, only three connections need be made from the vehicle's electrical system to the clock module. Constant dc power from the positive battery terminal, with the ignition on and off, is made to pad 3 on the module, while the negative side of the battery, or chassis ground, goes to pad 6. The ignition-controlled display on/off connection goes from the other side of the ignition switch to pad 1.

Optionally, you can add brightness control to the display by connecting a lead from the headlight switch to pad 4 on the module. Now, when the headlights are

turned on, the brightness of the display is reduced by two thirds, which reduces glare under nighttime driving conditions. Additionally, if your car is equipped with a dashboard-light level control (rheostat), a final wire from the wiper lug of the control to pad 2 on the module allows you to control the brightness of the display from full to about one-third brightness. No connections need be made from the vehicle's electrical system to pads 2 and 4 on the module for the clock to operate.

The green vacuum fluorescent display consists of four 0.3" (7.6-mm) digits with a colon between the minutes and hours. The green display allows the use of blue, green, or yellow filters.

The clock module itself is protected against automotive voltage transients and reversals. It is designed to keep time with supply potentials of nominally 12 volts down to approximately 9 volts dc. The clock draws 5 mA when operated with the vehicle's ignition off).

For wiring between the clock module and the vehicle's electrical system, it is best to use 20-gauge stranded hookup wire. You can use 22- or 24-gauge stranded hookup wire between the switches and module. (A kit of parts, including the MA-1003 clock module, three pushbutton switches, and triangular case described elsewhere in this article, is available for \$26.95 from: Digi-Key, Box 677, Thief River Falls, MN 56701. Please ask for the Kar Klok kit. Minnesota residents, please add state sales tax.)

wish to go to the bother of bending a sheet of acrylic plastic to make a case for your Kar Klok. In this event, you can substitute an acrylic cylinder for the body of the clock and use square end pieces (see Fig. 8). Select tubing with a 1 $\frac{3}{4}$ " (44.5-mm) inner diameter and $\frac{1}{8}$ " (3.2-mm) wall thickness and cut it to 3 $\frac{1}{8}$ " (8 cm) in length. The end pieces should form squares that measure 2 $\frac{1}{4}$ " (57.2 mm) on each side from $\frac{1}{8}$ " or $\frac{1}{4}$ " thick acrylic plastic sheet.

Acrylic tubing for craft work is usually crystal clear. However, if you prefer a transparent color tint, solvent-based dyes that simply brush onto the plastic are available. You can use the crystal clear tubing as is with crystal clear or color tinted end pieces to better show off the Kar Klok's "innards."

To locate the holes for the three pushbutton switches, slip the module into the acrylic tube and note and mark where the holes should be drilled. When you drill the holes for the switches, drill a fourth hole of the same diameter for the wires that connect to the vehicle's electrical system to exit the case. Then drill a line of $\frac{1}{8}$ " holes at the top and bottom of the case, spacing them about $\frac{3}{8}$ " (9.5 cm) apart to allow air to cool the clock module when it is installed in the case.

Cement one end piece to the cylindrical body. Slip the clock assembly into the case, fasten down the switches in their appropriate locations, and route the electrical-system hookup wires through the hole drilled for them. Then cement the other end piece to the case. Finally, use Velcro strips to mount the Kar Klok to your dashboard and connect the wires to your car's electrical system as shown in the box.

In Closing. The world of acrylic plastic provides the electronics hobbyist with a practical and inexpensive means for custom designing and fabricating cases for his projects. In this article, we have detailed the basic techniques for working with acrylic plastics. With a little practice and by exercising some imagination, you can be making custom cases for all your projects in short order. For example, you might substitute wood for the end panels of your cases or use a wood base with a brushed aluminum pedestal on which to mount an acrylic-cased project. The combinations of materials and styles are almost limitless.

The Kar Klok project presented here is a practical automotive accessory that is particularly suitable for exercising your imagination in designing custom plastic cases. ◇



Solid State

IC AUDIO PREAMPLIFIERS

By Lou Garner

SEMICONDUCTOR devices have been used in audio amplifiers ever since the transistor first became a practical commercial product. In fact, to a large degree it was the continuing search for improved and more efficient audio amplifiers and switches which led to the invention of the transistor by scientists of the Bell Telephone Laboratories in the late 1940's. The first consumer application of transistors was as audio amplifiers in hearing aids, followed shortly thereafter by their use in the audio sections of AM radio receivers and as preamplifiers for vacuum tube operated audio systems. As time passed, the mass production of junction transistors for the hearing aid industry resulted in a surplus of units which didn't meet the critical requirements of hearing aid designs but which, nonetheless, were excellent amplifiers. These devices were made available to the retail market through local distributors as moderately priced "experimenter's transistors," opening a whole new field for the experimenter and hobbyist.

Originating back in the heydays of vacuum-tube amplifiers, the preamplifier often was an afterthought—that is, an extra retrofitted circuit used to boost relatively weak signals prior to processing by a conventional amplifier. Sometimes the preamp, as it came to be known, was incorporated as part of an external signal source, such as a condenser microphone or magnetic phono pickup. In other cases, the preamp was an add-on circuit mounted directly on the main amplifier chassis and using the same power source. In still other cases, it was a separate piece of self-contained equipment with an integral supply as well as input and output jacks. In those early days, the preamp generally was a single- or dual-stage circuit designed to furnish some frequency compensation as well as modest gain. It seldom was equipped with gain or tone con-

trols, however, for these were found in the main amplifier assembly.

Today's preamp designs range from simple single-purpose configurations to complex circuits with nearly as many controls as an oscilloscope. Depending on equipment performance requirements, the preamp may be used only as a buffer or isolation amplifier. More often, it serves to provide additional gain and impedance matching as well as frequency compensation, equalization, and control. While early solid-state audio preamps usually employed from one to four discrete transistors, current designs commonly feature one or more integrated circuits. General-purpose operational amplifiers are perhaps the most widely used devices as preamps, with FET-input types increasingly popular among design engineers because of their high input impedance characteristics.

Typical IC audio preamp designs are illustrated in Figs. 1 through 4. Abstracted from manufacturers' data sheets, application notes and similar published literature, these circuits all feature standard devices and commercial components and, therefore, are suitable for a variety of experimenter and hobbyist projects. Generally, layout and lead dress are not overly critical as long as good wiring practice is observed. This permits the circuits to be assembled using standard construction techniques, including pc or perf boards, solderless wirewrap, or conventional point-to-point wiring. In general, too, dc circuit power may be obtained either from batteries or well filtered and regulated ac line operated power supplies, at the builder's option. Since the required assembly and wiring time is but a few man-hours for most of the circuits, the designs are excellent for weekend projects.

Selected from data sheets published by the Signetics Corporation (811 East Arques Ave., Sunnyvale, CA 94086), the four simple audio preamp circuits shown in Fig. 1 are based on the NE542 dual low-noise preamp IC. However, the general designs may be used with a variety of amplifier IC's having similar electrical characteristics, including the LM381, LM381A, and LM387, with few, if any, changes in component values. Of course, pin connections vary with different IC's and an adjustment in dc supply voltages may be required for some types to achieve optimum performance. Of the four IC's in-

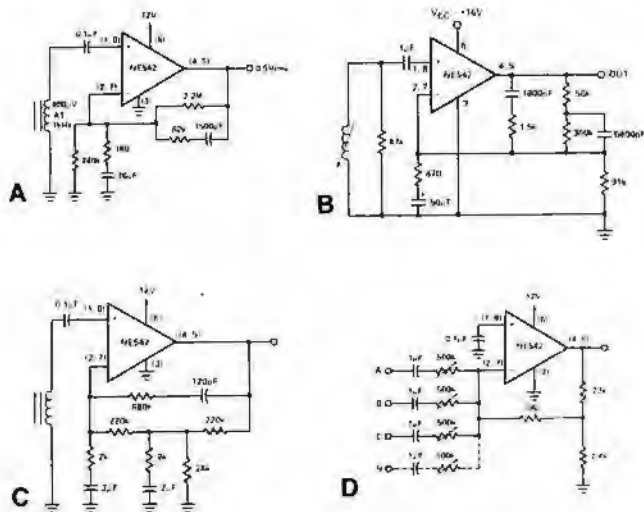

Fig. 1. Audio preamp circuits: (A) tape playback; (B) RIAA phono; (C) NAB tape preamp; (D) mixer.

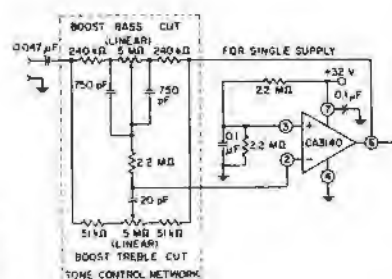

Fig. 2. This Bazardall tone control circuit uses a BIMOS unit.

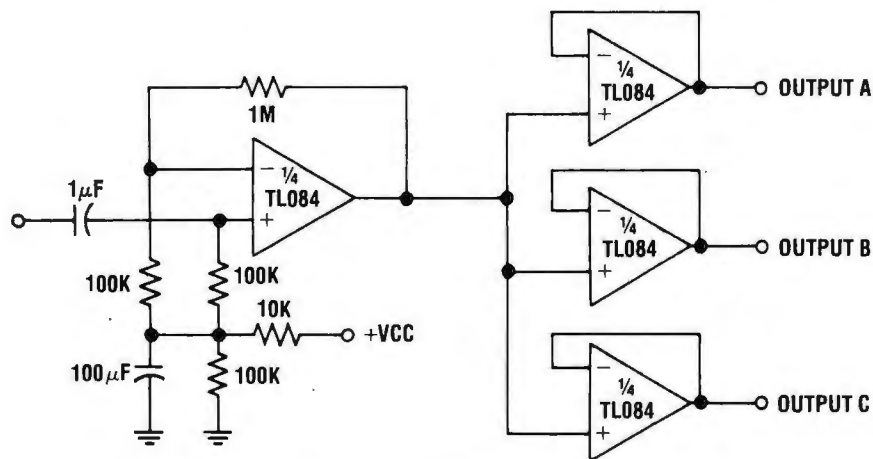

Fig. 3. This audio distribution amplifier circuit features multiple isolated outputs and can be used effectively in electronic musical instruments to achieve special effects.

licated, types NE542 and LM387 are supplied in 8-pin Mini-DIP's, while types LM381 and LM381A are furnished in standard 14-pin DIP's. All contain dual amplifiers, permitting a single device to be used for two-channel (stereo) systems.

A typical magnetic tape playback preamp circuit is illustrated in Fig. 1A. Requiring relatively few components, the circuit will deliver 0.5 V rms output when driven with an 800- μ V input signal (nominally, at 1 kHz) by the pickup coil. A modified preamp design providing RIAA equalization for use with standard magnetic phono cartridges is given in Fig. 1B. Intended primarily for broadcast equipment applications, a two-pole fast turn-on NAB tape preamp circuit is shown in Fig. 1C. Finally, a multiple input audio mixer circuit with independent gain controls is illustrated in Fig. 1D. All four preamp circuits are designed for operation on conventional single-ended dc power supplies.

Featuring a BIMOS device, the Baxandall tone-control circuit shown in Fig. 2 is one of a number of suggested applications described in a 20-page data brochure (File No. 957) published by RCA (Solid State Division, Box 3200, Somerville, NJ 08876) for the CA3140 op amp family. As described in April's column, the CA3140 is a dual-technology unit which combines a high-impedance MOSFET input stage with a bipolar output amplifier in a single op amp. The CA3140 devices are furnished in standard 8-lead TO-5 type metal cases. Using linear potentiometers, the Baxandall circuit, according to RCA, can furnish up to ± 15 dB bass and treble boost or cut at 100 Hz and 10 kHz, respectively, while providing a full peak-to-peak output of up to 25 V to at least 20 kHz. The amplifier's output is only -3 dB down at 70 kHz from its 1-kHz reference

level. With the controls set for a flat frequency response, the circuit offers unity (0 dB) gain. As shown, the circuit is intended for operation on a single-ended dc power supply. It can be modified easily for operation on a dual ± 15 -V dc source, however, simply by removing the offset bias network and returning pin 3 (+input) to circuit ground while connecting pin 4, bypassed to ground with a 0.1- μ F capacitor, to the negative supply terminal rather than to ground; all other circuit connections remain unchanged.

In contrast to the multiple input mixer described earlier (Fig. 1D), the audio distribution amplifier circuit illustrated in Fig. 3 features multiple isolated outputs. It can be used effectively in electronic musical instruments for special effects as well as in PA, music distribution, and intercom systems requiring multiple drives for several power amplifiers to achieve high output levels. It also can be used in light organ, audio control, and test instrument designs. Abstracted from 20-page Bulletin CB-248, published by Texas Instruments, Inc. (P. O. Box 5012, Dallas, TX 75222), the distribution amplifier employs a type TL084 quad operational amplifier. A member of TI's BIFET family, the TL084 comprises four identical JFET input op amps in a single 14-pin DIP. The device can be operated on dc supply voltages of up to ± 18 V, with each amplifier section offering an input impedance of 10^6 megohms, a unity gain bandwidth of 3 MHz, a slew rate of $12\text{V}/\mu\text{s}$, internal compensation, and continuous integral output short-circuit protection. Individual amplifier pin connections are not identified in the schematic diagram because the amplifier sections are interchangeable and the final selection can be made best by the equipment designer to achieve optimum layout and lead

Fig. 4. An audio preamp complete with gain as well as bass and treble tone controls.

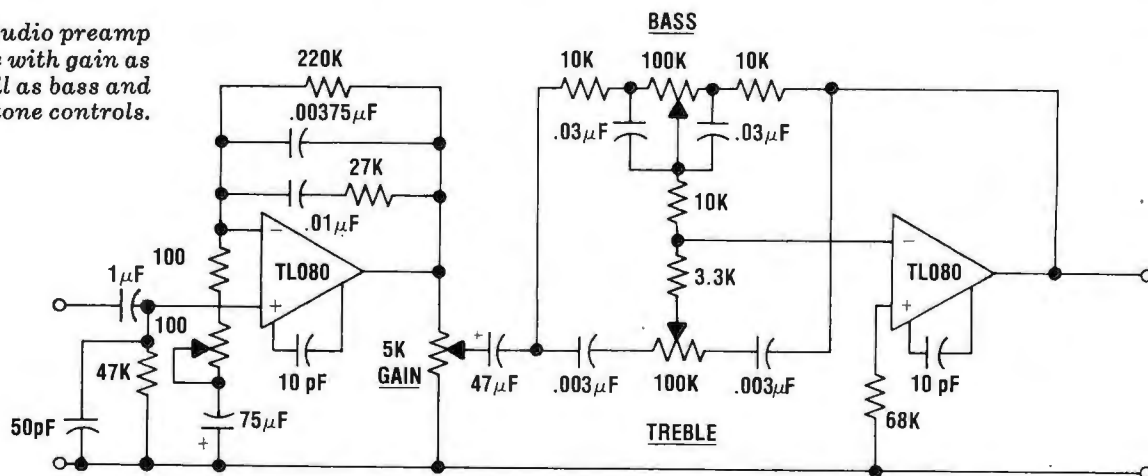

dress. In all cases, however, dc power supply connections are to pins 4 (+) and 11 (-).

Another TI BIFET circuit is given in Fig. 4—an audio preamp complete with gain as well as bass and treble tone controls. Intended for general purpose applications, the preamp can provide more than adequate drive for standard power amplifier designs. The circuit features the TL080, a single JFET input op amp which is offered in both 8-pin MiniDIP and TO-99-L style packages. Except for requiring external compensation (10-pF capacitors), the TL080's electrical characteristics are essentially similar to those of the individual amplifiers in the TL084, discussed earlier. The device's pin assignments are the same as those of such standard op amps as the LM301A, LM308, and μ A748.

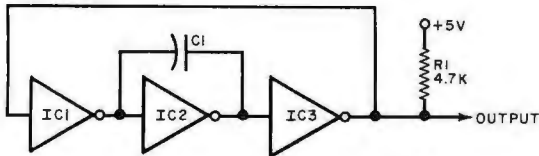

Fig. 5. Square-wave oscillator circuit can deliver signals from 1 Hz to 1 MHz as value of feedback capacitor is varied.

Right On! In last January's annual "predictions" column, you may recall, I predicted a further breakthrough in the pricing of digital electronic watches . . . that commercially available watches would be offered in the "ten-dollar range." Ah so! *Texas Instruments, Inc.*, which originally broke the twenty-five dollar price barrier for digital watches, per an even earlier prediction, *has done it again!* In a recent press release, TI announced a reduction in the suggested retail list price of its model 503 sports/youth watches from \$19.95 to a low \$9.95!

Reader's Circuits. If the bulging mail bag is any indication, many of our readers have been quite busy devising and testing new circuits.

While on the subject of mail—a personal word to those of you who may have written and not received answers to your letters and postcards. The volume of mail generated by a magazine with a readership of 400,000 is simply too much for one guy to acknowledge personally. However, be assured that all letters are read and given full consideration. If you don't receive an answer to your inquiries promptly (or even at all), it isn't due to a lack of interest. It's simply because we don't have time. But please, please keep us posted about your interests and keep sending those interesting circuits.

We have a twenty-year old French-Canadian reader, Guy Isabel (1725, Henri-Bourassa East Blvd., Apt. 25, Montreal, Quebec, H2C 1J8, Canada), to thank for the simple and inexpensive square-wave oscillator circuit illustrated in Fig. 5. It is capable of delivering signals at frequencies ranging from 1 Hz to 1 MHz as the feedback capacitor's value, C_1 , is varied from 300 μ F to 300 pF. The circuit may be used as a "clock" in digital applications, as a simple square-wave generator for test instruments, or as a basic tone source for alarms and electronic musical instruments.

The duty cycle is approximately 50% and is independent of the feedback capacitor's value. The three active devices making up the oscillator, IC_1 , IC_2 , and IC_3 , are three sections of a standard type 7405 TTL open-collector hex inverter. Pull-up resistor R_1 is a half-watt unit, while capacitor C_1 may be a ceramic, plastic-film, paper or electrolytic type, depending on

MAKE GREAT CONNECTIONS!



IC INTERCONNECT ASSEMBLIES
26 Ga. Ribbon Cable

IC SOCKETS
3 Level Wire Wrap Gold

	1-9	10-24	25-100
14pin	.38	.27	.26
16pin	.42	.41	.40
18pin	.73	.65	.59
24pin	1.00	.91	.83
40pin	1.69	1.51	1.37

Low Profile D.I.P., Solder tail, (TIN)

SINGLE END

	6"	12"	18"	24"	36"	48"
14 pin	1.31	1.62	1.77	1.80	2.05	2.26
16 pin	1.64	1.76	1.87	1.99	2.21	2.44
24 pin	2.49	2.69	2.88	3.08	3.48	3.87

DOUBLE END

	14 pin	16 pin	18 pin	24 pin	30 pin	36 pin
14 pin	2.76	3.01	3.13	3.24	3.36	3.58
16 pin	3.01	3.13	3.24	3.36	3.58	3.81
24 pin	4.35	4.75	4.94	5.14	5.54	5.93

Use for mounting diodes, resistors, jumpers, etc.

DUAL IN-LINE PLUGS

	1-24	25-49	1-24	25-99
8 pin	.46	.39	.10	.09
14 pin	.48	.40	.10	.09
16 pin	.56	.47	.10	.09
24 pin	.79	.72	.15	.13
40 pin	\$1.23	\$1.08	.25	.22

COVERS

S-100 BUS CONNECTORS 2 x 50 x .125"
WIRE WRAP TERMINATIONS \$3.75
SOLDER TAIL TERMINATIONS \$3.75
4 S-100 CONNECTORS - ANY MIX - \$14.00

YES! WE HAVE



WIRE-WRAPPING TOOLS

Hobby-Wrap-30 & 30M

REGULAR WRAP

MODIFIED WRAP

NEW

Free 50' wire with either tool

Only \$34.95

Batteries not included.

Replacement Bit BT-30...\$2.95

Regular Wrap	WSU-30	\$5.95
Modified Wrap	WSU-30M	\$6.95

TRI-tek, Inc.
6522 R NORTH 43RD AVENUE,
GLENDALE, ARIZONA 85301

Minimum Order: USA, \$10
Foreign, \$15 in US Funds.
Surface Shipping Prepaid.
Add 50¢ insurance

SEND FOR FREE CATALOG

CIRCLE NO. 60 ON FREE INFORMATION CARD

PRINTED CIRCUIT KITS MAKE CARDS QUICKLY



- ONLY Vector kits contain:
- Positive photo-resist coated AND uncoated copper laminate—no messy photo-reversal—no spraying, dipping, or baking.
 - 4 types of art aids: rub transfers, ink, tape, cut and peel—use 1 or all.
 - 1:1 circuit art rub transfers—IC sets, pads, lines, connectors, symbols, letters, and numbers.
 - Everything included—just add water and sunlamp or bright sunshine.
 - Liquid etchant and developer—no dry chemical mixing problems.
 - AND
 - Process choices—make circuit on copper and etch for 1 card. Make circuit on film, expose, develop and etch for 1 or many cards.

ART AIDS + mylar film + sunlamp cards + developer & etchant = 1 or many PC's

+ card + etchant = 1PC

32XA-1 kit makes 7 PC cards, \$28.00, 32X-1 starter kit makes 2 cards, \$11.50

Vector Electronic Co., 12460 Gladstone Av., Sylmar, CA 91342

510177

CIRCLE NO. 61 ON FREE INFORMATION CARD

The better the training the better you'll

Send for
FREE
illustrated
career
guide

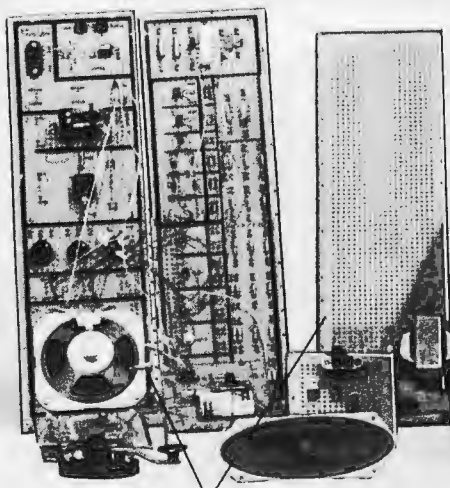
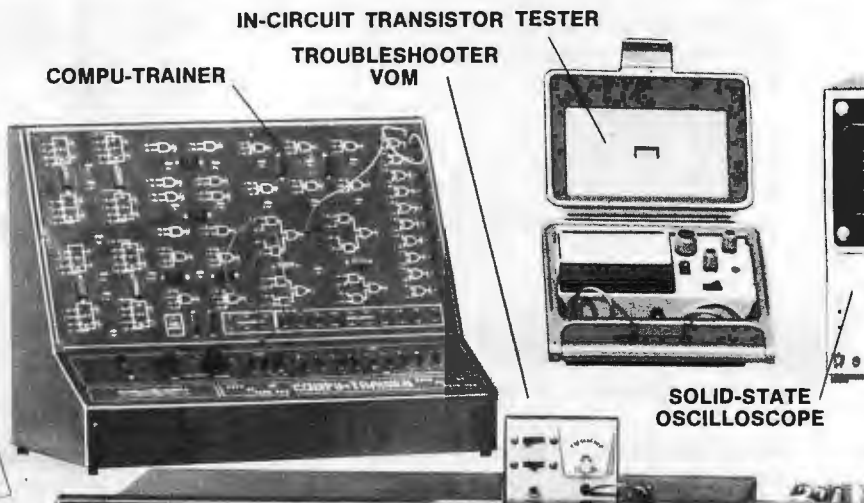
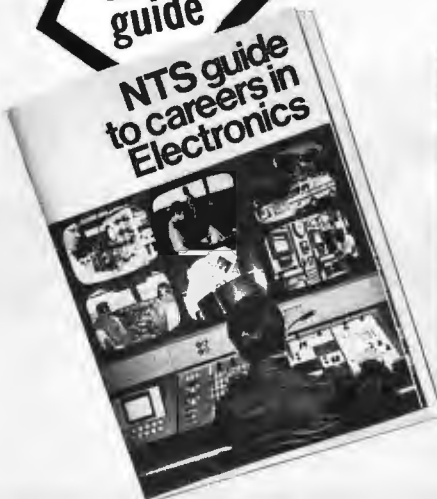

As an NTS student you'll acquire the know-how that comes with first-hand training on NTS professional equipment. **Equipment you'll build and keep.** Our courses include equipment like the **NTS/Heath GR-2001 computerized color TV (25" diagonal)** with varactor diode tuning and digital read-out channel selection; (optional programming capability and digital clock avail.).

Also pictured above are other units — 5" solid state oscilloscope, vector monitor scope, solid-state stereo AM-FM receiver with twin speakers, digital multi-meter, and more. It's the kind of better equipment that gets you better equipped for the electronics industry.

This electronic gear is not only designed for training; it's field-type — like you'll meet on the job, or when you're making service calls. And with NTS easy-to-read, profusely illustrated lessons you learn the theory behind these tools of the trade.

Choose from 12 NTS courses covering a wide range of fields in electronics, each complete with equipment, lessons, and manuals to make your training more practical and interesting.

Compare our training; compare our lower tuition. We employ no salesmen, pay no commissions. You receive all home-study information by mail only. All Kits, lessons, and experiments are described in full color. Most liberal refund policy and cancella-

and the equipment be equipped.

**COMPARE OUR
KITS AND LESSONS.
COMPARE OUR
TUITION.**



HIGH FIDELITY
SPEAKERS

SOLID-STATE STEREO
AM/FM/MULTIPLEX
RECEIVER

COLOR BAR/DOT
GENERATOR

TUBE & TRANSISTOR TESTER

FET-VOM

AM/FM/SW PORTABLE
SOLID-STATE RECEIVER

VECTOR MONITOR
SCOPE

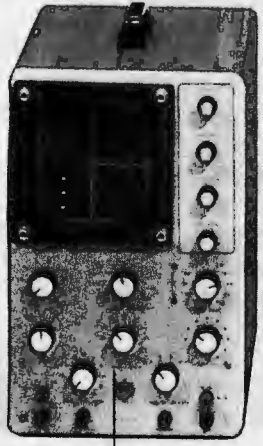

5" OSCILLOSCOPE

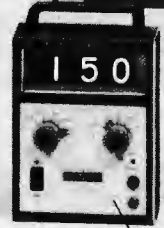

DIGITAL
MULTIMETER



SOLID-STATE 2-METER FM
TRANSCEIVER & POWER SUPPLY



SOLID-STATE
POCKET RADIO

SIGNAL
GENERATOR

tion privileges spelled out. Make your own comparisons, your own decision. Mail card today, or clip coupon if card is missing.

NO OBLIGATION. NO SALESMAN WILL CALL
APPROVED FOR VETERAN TRAINING
Get facts on new 2-year extension

NATIONAL TECHNICAL SCHOOLS

TECHNICAL-TRADE TRAINING SINCE 1905
Resident and Home-Study Schools
4000 So. Figueroa St., Los Angeles, Calif. 90037

NATIONAL TECHNICAL SCHOOLS Dept. 205-097
4000 South Figueroa St., Los Angeles, Calif. 90037
Please send FREE Color Catalog and Sample Lesson.
NO OBLIGATION. NO SALESMAN WILL CALL.

<input type="checkbox"/> Color TV Servicing	<input type="checkbox"/> Electronics Technology
<input type="checkbox"/> B & W TV and Radio Servicing	<input type="checkbox"/> Computer Electronics
<input type="checkbox"/> Electronic Communications	<input type="checkbox"/> Basic Electronics
<input type="checkbox"/> FCC License Course	<input type="checkbox"/> Audio Electronics Servicing

NAME _____ AGE _____
ADDRESS _____ APT # _____
CITY _____ STATE _____
Please fill in Zip Code for fast service _____
 Check if interested in G.I. Bill information.
 Check if interested ONLY in classroom training in Los Angeles.

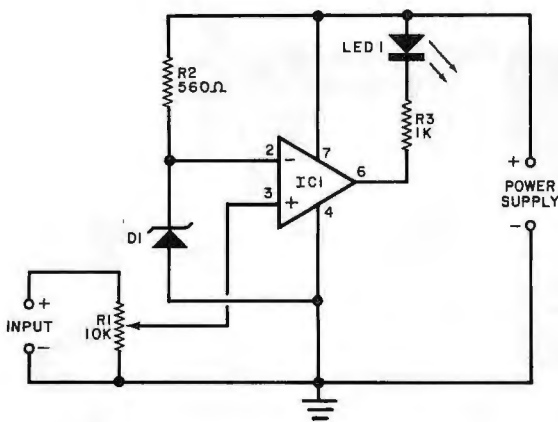

Fig. 6. This dc low-voltage monitoring circuit uses a standard op amp IC as a voltage comparator and to drive the LED output indicator.

value. With neither parts placement nor wiring arrangement critical, the circuit can be assembled in a small metal or plastic case with an integral dc power source as a self-contained instrument or incorporated as part of a more complex piece of equipment, at the individual builder's option.

Ted Reiter (1442 Brook Drive, Titusville, FL 32780), a frequent contributor to these pages, suggests that his dc low-voltage monitoring circuit might be of value to other experimenters and hobbyists. Ted's circuit, Fig. 6, uses a standard op amp, IC1, as a voltage comparator and output indicator

driver. In operation, a portion of the monitored voltage, determined by R1's adjustment, is compared to a fixed voltage obtained from a zener reference network, R2-D1, by IC1. As long as the monitored voltage remains at or above its present monitor point (determined by R1's setting), the output indicator, LED1, remains dark. If the voltage drops below this level, however, the indicator is activated.

The circuit can be set to operate within millivolts of a chosen setpoint level. Standard components are used in the design: IC1 is a type 741 op amp, R1 a conventional potentiometer, R2 and R3 one-quarter or one-half watt resistors, D1 a 3.3-volt zener, and LED1 a familiar red LED. A 12-volt dc power supply is suitable for monitoring input voltages of up to 12 volts, but a 15-volt power supply should be used for higher levels (up to 13.8 V). Since the circuit is essentially a dc amplifier, neither layout nor lead dress are critical.

Seeking a simple combination clock and single-pulse signal source for his digital experiments, Charles D. Baker (1141-18 Minto Ave., Kenora P9N 3K1, Ontario, Canada), devised the circuit in Fig. 7. Intended for operation on a standard TTL 5-volt dc source, the instrument can be used as a conventional clock, a two-phase clock, or a manually operated single-pulse generator.

The instrument's single active device is a standard TTL hex inverter, IC1. Three of the inverter sections are coupled together as a ring oscillator, with feedback capacitor C1 determining the frequency of operation (or clock rate). Shunt resistor R2 biases one inverter section into its active region to insure oscillation. Two of the sections are interconnected as a modified one-shot, delivering a negative-going output pulse, while the remaining section serves as a conventional inverter/buffer to deliver positive-going pulses.

The instrument's mode of operation is determined by function switch S1. When S1 is in its PULSE position, output pulses are delivered each time pushbutton switch S2 is depressed, discharging C2 through R4, and delivering a step signal through series isolating resistor R1. Between pulses, C2 is recharged through R5. When S1 is in its CLOCK position, the ring oscillator drives the one-shot through R1, and a continuous series of positive- and negative-going pulses is developed at a rate determined by C1's value.

Readily available components are used in the circuit. The hex inverter is a standard 7404. Capacitor C1's value and type are determined by the clock rate needed; and C2 is a

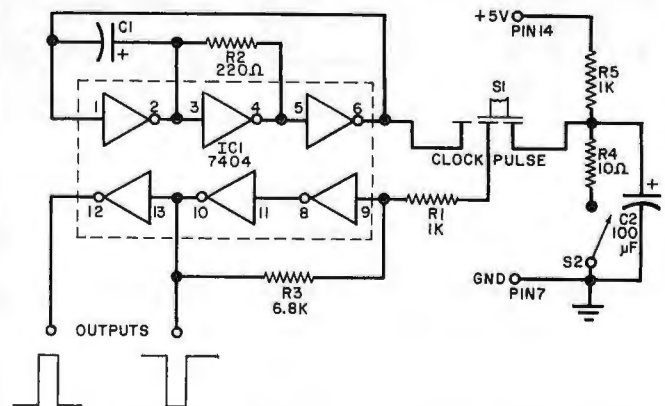

Fig. 7. Simple circuit using standard TTL hex inverter can be used as a conventional clock, two-phase clock, or single-pulse generator.

computer depot[®] inc.
(Credit Cards Accepted)

3515 W. 70TH ST. • MPLS., MN 55435 • (612) 927-5601

SPECIALS

PARTS					
7405	\$.15	7476	\$.30	74123	\$.60
7410	.15	7492	.35	74145	.50
7427	.20	7493	.35	74150	1.00
7442	.40	7496	.50	74151	.60
7446	.60	74121	.30		

SYSTEMS

IMSAI 8080 Assembled Systems with 22 Slot Mother Board		
SAVE \$143.00		ONLY \$850.00
IMSAI 8080 Kit Form same as above		
SAVE \$ 51.00		ONLY \$700.00
EDGE CONNECTORS \$5.00 Ea.		
S-100 Type 6 for \$ 25.00		SAVE \$ 12.00
TARBELL TAPE INTERFACE KIT		
SAVE \$ 10.00		ONLY \$110.00
OLIVER PAPER TAPE READERS		
SAVE		ONLY \$ 69.95

BOOKS
Take 10% Off

T.V. TYPEWRITER COOKBOOK By Don Lancaster	..	\$ 9.95
ACTIVE FILTER COOKBOOK By Don Lancaster	\$14.95
BASIC BASIC By James S. Coan	\$ 7.95

BUG BOOKS

I + II Both for	..	\$17.00	V	..	\$9.95
IIA	5.00	VI	9.95
III	15.00			

TRANSISTOR TRANSISTOR LOGIC

BASIC Albrecht	\$ 4.95
FAIRCHILD MOS DATA BOOK	\$ 2.95
FAIRCHILD LINEAR TC	\$ 3.49
FAIRCHILD L.P. SCHOTTKY + MACRO LOGIC TTL	\$ 2.95
BASIC FOR BEGINNERS	\$ 7.95

ACCESSORIES

E + L INSTRUMENTS				
SK10 Bread Board Socket	..	REG. \$16.50	..	\$15.00
FAIRCHILD TECHNOLOGY KIT				
Automobile Clock Kit			\$40.00
AP PRODUCTS				
IC Test Clip 14 pin	REG. \$ 4.50	NOW \$ 4.00	
HUNTER TOOLS				
Continuity Tester	REG. \$ 3.49	NOW \$ 3.00	

100- μ F, 6-volt electrolytic. Function switch *S1* is a spdt toggle, slide, or lever switch, while *S2* is a spst, momentary contact, NO pushbutton switch.

At the builder's option, the instrument may be housed in a small metal box, a plastic case, or in a probe body. If assembled in a box or case where there is ample space, the builder may wish to include several different values for *C1*, selectable by means of a multi-position rotary switch, to provide a choice of clock rates. Typical values may range from a fraction of 1 μ F to as high as several thousand μ F. According to Charles, the ring oscillator can be operated at rates from 1 Hz to 1 MHz, depending on *C1*'s value.

Device/Product News. A new series of high-voltage, high-current, silicon npn transistors, types RCA9113, RCA9113A, and RCA9113B, has been announced by RCA's Solid State Division (Box 3200, Somerville, NJ 08876). Designed for use in off-line switch-mode power supplies, inverters, converters, pulse-width-modulated regulators, and motor controls, the new transistors feature high-voltage capability, fast switching speeds, and low saturation voltages, together with high SOA ratings for both forward- and reverse-bias conditions. With a peak collector current rating of 22 A and a maximum power dissipation of 175 W (at 25°C), the new transistors are supplied in standard TO-3 packages.

Motorola Semiconductor Products, Inc. (Box 20912, Phoenix, AZ 85036) has announced some new devices of potential interest to hobbyists and experimenters, including an extremely stable 2.5-V reference source and a monolithic automotive electronic ignition control IC.

Designed for critical instrumentation and D-A converter

applications, the new voltage-reference source, type MC1403/1503, features a maximum output voltage variation of only 1% (± 25 mV) and a typical temperature coefficient of 10 ppm/°C. It also features a line regulation of 3 mV (max) at input voltages from 4.5 to 15 V or 4.5 mV (max) from 15 to 40 V, together with a load regulation of 10 mV (max) at output currents from 1 to 11 mA.

Intended for circuits utilizing a flux-averaging sensor instead of conventional ignition "points" and condensers, the ignition control IC, type MC3333, is designed to drive a Darling-ton power transistor which supplies the current required by a high-energy ignition coil. Housed in a 14-pin DIP, the MC-3333 can operate at battery voltages from 4 to 24 volts.

Fairchild's Optoelectronics Division (4001 Miranda Ave., Palo Alto, CA 94303) has plunged into the hobbyist market with the introduction of a series of electronic construction kits. Designated as *Solid State Technology Kits™*, the new line includes an alarm clock-calendar (Model 0100), a wall clock (Model 0101), and an automotive digital clock. All of the kits feature LED displays. Future products planned for the line include additional clocks, a DVM and a frequency counter.

Meanwhile, another Fairchild division (Components Group, 464 Ellis Street, Mountain View, CA 94042) has announced a new 2-A monolithic voltage regulator designed primarily for use in power supplies for home-base CB radio equipment. The new device, type μ A78CB, features a fixed output voltage of 13.8 volts, internal thermal overload protection, short-circuit limiting, a peak current capability of better than 4 A, and an output voltage tolerance of 5% over the 0° to 125°C temperature range. Available in both TO-3 and TO-220 packages, the new regulator can dissipate up to 20 watts. \diamond

STAY TURNED ON with your low power friends from CIS

Autoranging DMM \$ 99.95
Frequency Counter \$119.95
Logic Probe \$ 34.95

Liquid crystal displays, plus CMOS designed testers offer you long life from a single 9 volt battery.

AUTORANGER™ DMM. Fast responding 3.5 digit liquid crystal display with full automatic operation. Autoranging up to 1000 volts and 2000 K Ω . Automatic zeroing. Automatic polarity sensing. Protected to 600 vdc, 10 Meg Input. Resolution 1 mv. Accuracy DCV 0.5% reading - 1 digit. All for \$99.95.

30 MHZ FREQUENCY COUNTER. Liquid crystal 6 digit display allows 8 digit Resolution when switching the range to an overflow condition. 200 mv rms sensitivity and input of 10 K Ω minimum. RCA phono connection. \$119.95.

PROBIT™ LOGIC PROBE. Tests TTL/CMOS pulses-down to 35 NS and frequencies up to 40 MHz. Uses 7 segment LED display — "H", "L", "dot" for pulses. Flexible, detachable tip plus "Micro-Hooks" for power. Includes pocket carrying case. \$34.95.

FREE 15 DAY TRIAL. Be convinced or get your money back. Full 90 day warranty. Each tester shipped complete with battery, schematic, assembly drawing, parts lists.

For More Convenience, Call Now With Your Order
TOLL FREE: 1-800-527-4634
(Texas Residents 1-214-234-4173)



Yes, Send _____ DMM Autoranger™ @ \$99.95
Send _____ Frequency Counters @ \$119.95
Include _____ DMM/FC Carry Cases @ \$3.95
Send _____ Logic Probes @ \$34.95
Add Shipping \$2.00 each
(Texas Residents add 5% sales tax)

Control & Information
Systems, Inc.
30 Spring Valley Village
Richardson, Texas 75080

M/C _____ BAC _____
Check or MO enclosed.

Name _____
Street _____
City _____
State _____

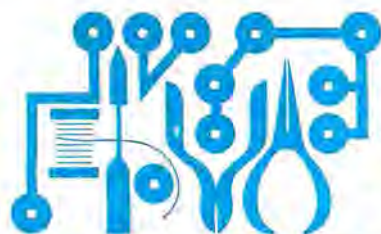

Experimenter's Corner

By Forrest M. Mims

LASER DIODES

IN OCTOBER the semiconductor laser diode will celebrate its fifteenth birthday! Even in this era of complex integrated circuits, the laser diode remains one of the most remarkable electronic components yet invented.

In some ways the laser diode closely resembles its first cousin, the light emitting diode (LED). For example, both diodes produce infrared or visible light when electrons recombine with holes at a forward-biased pn junction.

and communications applications.

The laser diode is nothing more than a carefully made LED with an ultra-flat junction and two tiny mirrors. The mirrors face one another and produce the internal feedback which leads to *stimulated emission of radiation*, the process responsible for laser action. Stimulated emission occurs naturally when a light photon emitted by an excited electron strikes a second excited electron and forces it to recombine with a hole. The

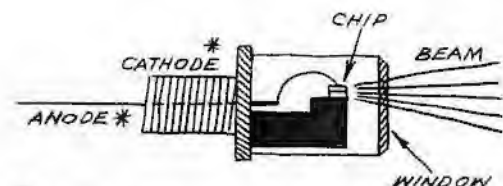

Fig. 1. How a typical laser diode works.

* USUAL POLARITY. REFER TO INFORMATION SUPPLIED WITH YOUR LASER

The electrons are excited to a higher than normal energy level, enabling them to cross the potential barrier formed by the junction. When they fall into holes after crossing the junction, they give up their excess energy in the form of radiated heat and light. The better the diode is, the more light than heat it produces.

This method of light generation, is called *spontaneous emission*, as it's pretty much a random process. Electrons and holes recombine whenever the opportunity presents itself, and the result is a chaotic jumble of light waves. Fortunately, the relatively constant energy levels the electrons can occupy before crossing the junction limits the energy each electron can absorb. This restricts the radiated light to a reasonably narrow band of wavelengths (100-150 nanometers). Light is emitted at a *much* faster rate (within a few tens of nanoseconds) than that from most other sources. That's why LED's and laser diodes are ideal for detection, ranging,

result is *two* photons having almost identical frequency and traveling in perfect phase with one another. As you can see, stimulated emission is a type of amplification. Normally it occurs only rarely, but the two feedback mirrors of a laser cause stimulated photons to be reflected back and forth within the laser material and the result is a cascade of oscillating photons—or laser light.

Most laser diodes are made by producing precise, sandwich-like junctions in wafers of gallium arsenide (GaAs) or other efficient light-producing semiconductors. The wafers are then cleaved into thin bars, which are sawed into individual laser chips several mils on a side (about the size of the dot on this letter "i"). The cleaving process gives each chip two perfectly parallel facets which serve as the mirrors. Individual chips are usually installed in a protective package with a plastic (OK) or glass (much better) window and a miniature, built-in heat sink (Fig. 1).

Driving Laser Diodes. Both LED's and laser diodes will produce recombination radiation when driven at very low levels of forward current. Lasers, however, will not lase until the forward current exceeds a level called the *threshold* (J_{th}). Above J_{th} , the optical power from the laser increases linearly with current. Many lasers will emit several watts or more when pulsed with 10- or 20-ampere pulses.

You may have read about the new generation of laser diodes which can be operated *continuously* without having to be cooled to the temperature of liquid nitrogen. Primarily designed for high-bandwidth communications through glass fibers, these lasers are a delight to use, but are temperature-sensitive and limited to several milliwatts of output power. They are not yet available at hobbyist prices.

Single heterostructure (SH) lasers, the kind you can buy at bargain prices from some of the suppliers who advertise in POPULAR ELECTRONICS, have a J_{th} of 5-10 amperes. Apply this much current to a SH laser diode and the chip will literally explode! The only safe way to drive an SH laser without cooling it with liquid nitrogen is to use current pulses no more than 200 nanoseconds wide.

The avalanche transistor circuit shown in Fig. 2 offers an excellent way to generate high-current pulses only 50-75 nano-seconds wide. Different transistors avalanche at different voltages, so you'll have to select a specific transistor for your particular laser. Briefly, you should *NOT* connect a laser to the circuit until you have selected and verified the operation of Q1. Remember—laser diodes don't like too much

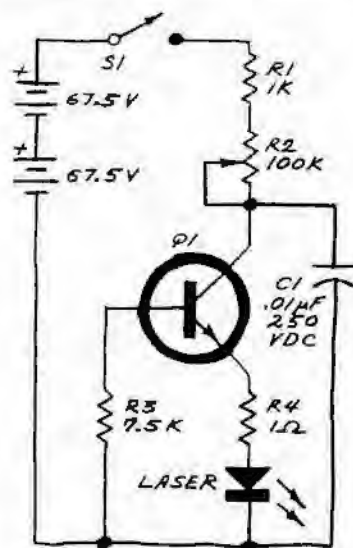

Fig. 2. Avalanche transistor circuit.

drive current! A good rule of thumb is to limit the maximum current to 2.5-3 times the threshold current. Both values are usually supplied with the laser.

Select Q1 by connecting a short copper wire in place of the laser and a fast oscilloscope (at least 15 MHz) across current monitor R4. This resistor must be carbon composition, NOT wire-wound. Use ten 10-ohm carbon resistors in parallel if you can't find a suitable 1-ohm component. Keep all leads in the current discharge path (Q1, C1, R4, and the LASER) as short as possible. The height of the pulses on the scope screen in volts will equal their peak current in amperes. Many, but not all, transistors will oscillate in this circuit. You should have good results with most common npn silicon switching transistors such as 2N914, 2N2222, 2N3643, 2N4400, 2N5188, HEP50, etc.

After the driver circuit is working and Q1 is selected and in the circuit, you can install the laser. Pay attention to its polarity! Don't expect a spectacular red beam. Although the beam is truly impressive to see, it's invisible. To verify its presence, you'll need a photodetector sensitive to the 900-nanometer infrared radiation. Silicon photodiodes driving fast amplifiers work best. Phototransistors and silicon solar cells are marginal detectors because they have very slow response times. Photoresistors simply will not work.

To see the beam you'll need an infrared image converter such as a snooper-scope or silicon vidicon TV camera. The cheapest way to see the beam is to order a plastic, phosphor-coated infrared viewing card from Kodak Special Products Sales, Rochester, NY 14650. The viewing card costs about \$30—but that's a bargain compared to the cost of an image converter.

With the help of an image converter or viewing card you can quickly squeeze the 20- x 40-degree beam from the laser into a pencil-thin beam as narrow as that emitted by the popular helium-neon laser. All you need is a convex f1 lens. A good source for lenses and other optics is the Edmund Scientific Co., Edscorp Bldg., Barrington, NJ 08007.

Safety Considerations. Fortunately, the beam emitted by most laser diodes is reasonably safe because of its low average power. Nevertheless, as with any bright light source, you should avoid viewing the beam directly. You should also avoid pointing the beam at other persons or toward reflective surfaces. ◇

The Affordable Programmable

Never Before A Fully Programmable Calculator Available To The Scientific Community At Such A Low Cost!



by Mail Order
\$59⁹⁵

CALL TOLL FREE
800-621-8318
24 HOURS - 7 DAYS

SUMMARY OF SPECIFICATIONS

- 12 DIGIT RED L.E.D. DISPLAY entries or results in 3 modes, scientific, fixed point or engineering
- PROGRAMMABLE—72 Keystroke program storage
- TRIG FUNCTIONS—Calculates in radians or degrees or grads
- HYPERBOLIC FUNCTIONS
- Ln, log, e^x, 10^x
- POWERS Y^x, Roots: √Y
- FUNCTIONS OF X—1/x, √X
- LINEAR REGRESSION: TREND ANALYSIS: SLOPE AND INTERCEPT
- STATISTICAL: Σ+, Σ-, averages, standard deviation, variance, permutations, combinations
- PERCENTAGE CALCULATION—add on/discount/yield/Δ percentage
- AND CHANGE SIGN KEY
- 10 MEMORIES—7 functions—M+, M-, MR, Mx, M+, STORE, 9M
- DEGREES/DEGREE, MINUTE, SECONDS CONVERSION
- RADIAN/DEGREE CONVERSION
- POLAR/RECTANGULAR CONVERSION
- 8 METRIC CONVERSIONS
- SPHERICAL/CARTESIAN CONVERSIONS

The Commodore PR (Personal Resource) 100—Allows You To Personally Program According To Your Own Problem-Solving Needs!

WHY A PROGRAMMABLE?

The Commodore PR-100 Programmable Calculator introduces a new, innovative dimension in highly sophisticated mathematical and scientific problem-solving. It decentralizes and personalizes the decision-making power of the computer, bringing to you what was never before available in a programmable calculator with such features, yet at an amazingly affordable price.

Method of Entry: The Commodore PR-100 is designed for "Think and Touch" operation utilizing an algebraic mode of entry. You can enter equations which have up to 4 levels of parenthesis. Add to these features the 10 memory registers, and you can work the most complicated mathematical, scientific, engineering, business, statistical and combinational functions. Furthermore, you can also perform unit conversions: metric to English and English to metric.

Keyboard: The keyboard consists of 40 keys and 2 switches. 35 keys are for number and function entry. 10 of these keys are dual function (shifted keys).

SPECIALIZED FUNCTIONS:

Most of the important functions found on large scale computer systems are finally now available to you on the ultimate hand-held programmable calculator: iterative and recursive problem solving techniques; looping; conditional and unconditional branching.

ADVANTAGES OF THIS PROGRAMMABLE:

Consider for a moment the advantages of the Commodore PR-100. In terms of increased productivity you can now achieve the capability of: optimizing mathematical and scientific models; making trend and risk analyses; projecting and forecasting more accurately; performing statistical reductions; automating time-consuming "number-crunching."

The PR-100 is also a pre-programmed calculator that can achieve a multitude of functions: Basic +, -, x, ÷ and = functions; clear entry or the entire calculation; Hyperbolic functions include: sinh, cosh, arc cosh and arc tan; Trigonometric functions include: sin x, cos x, tan x, arc sin x, arc cos x, and arc tan x. Calculates in radians, degrees or gradians. Enter x 0° to 360° (0 to 2π) or multiples of 360° (2π). Natural Log (Ln x), Common Log (log x), Exponential (e^x), Antilog (10^x); Algebraic Functions include: x, x², 1/x. Powers: (Y^x); π (pi). Change Sign (+/-); x ↔ y exchange function; Parenthesis () enter equations that contain up to 4 levels of parenthesis without using temporary or intermediate storage.

Memory Functions: The PR-100 has 10 separate memory registers. For each memory there are 7 operations that can be performed: memory storage and clear, recall, addition, subtraction, multiplication, division and performs the desired functions on each memory.

NO LANGUAGE TO LEARN

Truly this programmable calculator is a powerful personal scientific and mathematical computing resource. And you don't need to know programming to make it work for you. There is no special language to learn. The entry system is so easy and flexible to use that you can apply it quickly to your own personal problem-solving techniques and style.

Special Functions of the PR-100: To allow you greater flexibility in programming, there are 3 special functions: 1. HALT—The program will halt and allow the user to read or enter data. 2. GOTO—Allows branching from one section of a program to another. 3. SKIP—Allows conditional flow of a program on an intermediate result; that is—the program goes one way if an answer is negative and another way is positive.

Loading, Editing and Modifying Programs: You can single step through a program to check it out, backstep through a program, easily read entered steps and modify a single step of a program.

Now personal programming is here. A step-function increase in capability over sophisticated slide-rule calculators. Capability you won't fully discover until you own a PR-100 yourself. Fill out the coupon below or call our toll free number for your two week trial.

The Commodore PR-100 is powered by rechargeable NiCad batteries and is furnished with an AC adapter/charger, leatherette carrying case and full instruction booklet. One year manufacturer's warranty. Dimensions: 3 1/4" x 6 1/2" x 1 1/8" Weight: 4 oz.

Compute With It For Two Weeks—No Obligation

Please send _____ Commodore PR-100 Calculator(s) at the introductory price of only \$59.95 (plus \$3.95 shipping and insurance) each. If not completely satisfied, I can return it within two weeks for a prompt refund.

Instead, I/we would like to take advantage of your quantity price offering of \$54.95 (plus \$3.95 shipping and insurance) each. OFFER GOOD ONLY ON QUANTITY ORDERS OF 6 UNITS OR MORE! You can save \$30.00!

Check or M.O. Enclosed (Ill. residents add 5% sales tax)
 Please charge my credit card checked below:
 American Express BankAmericard Carte Blanche
 Diners Club Master Charge

Credit Card # _____

Master Charge Bank # _____ Exp. Date _____

Name _____

Address _____

City _____ State _____ Zip _____

Signature _____ PE-9/77



Send Coupon To
Contemporary Marketing, Inc.
790 Maple Lane, Bensenville, Ill. 60106

Call Toll Free: 800-323-2272, Ill. call: 312-595-0461



By John McVeigh

MULTIPLEXED LED DISPLAYS

Q. In the Solid State Column on p.73 of the August 1976 issue, I saw the schematic for a stopwatch with a 6-digit display. Each segment's like digits (a through g) are connected in parallel, but none of the common cathodes of each display is grounded. Can you explain how the circuit works?—Santiago M. Quijano U., Bogota, Columbia.

A. This is an example of a multiplexed display (see diagram). When a particular SEGMENT ENABLE switch is closed, the anodes of all like segment diodes—say, segment *a* in digits 1 and 2, represented as 1*a* and 2*a*—are connected through a current-limiting resistor to the positive supply. However, unless the DIGIT ENABLE switches are closed, the cathodes are left floating above ground and no current can flow through the diodes. Thus the LED segments remain dark.

Now, if DIGIT ENABLE switch 1 is closed but switch 2 left open and SEGMENT ENABLE switches *a* through *f* are closed, digit 1 will form a "0." Opening DIGIT ENABLE switch 1, closing switch 2 and closing SEGMENT ENABLE switch *g* will cause digit 1 to go dark and cause digit 2 to form an "8." If this process is repeated very quickly, the two digits will appear to form "08" without any display flicker.

This is the basic principle of operation in a multiplexed LED display. Gates and

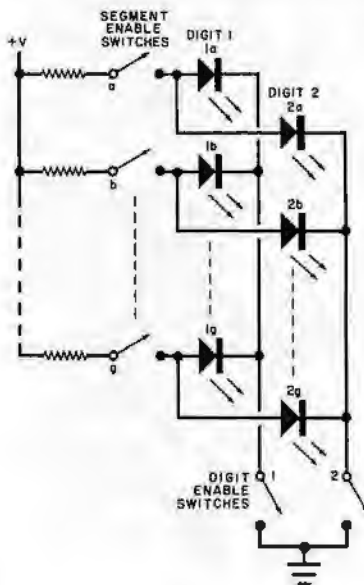

counters take the place of the mechanical switches, with their outputs either sourcing or blocking (segment enable outputs) current or sinking or blocking (digit enable outputs) current. A high-speed clock provides the necessary time reference. A large-scale integration chip (LSI) such as the Intersil ICM7205 contains all multiplex circuitry "on board." That's why the common cathodes are not shown grounded in the stopwatch schematic. The major advantage of multiplexed over direct-drive LED displays is reduced current demand—an important consideration in battery-powered equipment.

CAR CLOCK POWER SUPPLY

Q. I plan to build a digital clock/timer using a clock chip and a crystal-controlled time base. Do you have a circuit to reduce the car's 12-volt power source to +5-V dc with adequate regulation for the IC's?—Tom Ritch, Austin, TX.

A. You can use an LM309K IC regulator to step the 12 volts down to 5 volts regulated, as shown in the figure. Be sure to adequately heat sink the IC. Capacitors are used on both sides of the regulator to keep noise off the line, thus improving the stability of the regulator.

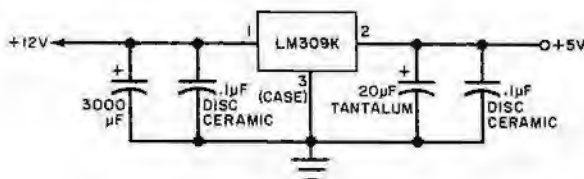

RESISTOR QUIZ

I would like to thank all the readers who have written in response to the Resistor Quiz in the July issue. Although some wrote suggesting answers such as 0 ohm, 1/4 ohm, 1/2 ohm, and 3/4 ohm, most arrived at the correct answer of 1/2 ohm. As you will recall, the problem involved finding the effective resistance between points A and B in the infinite matrix of 1-ohm resistors. Of those who reported the correct answer, some used a "shotgun" approach by having a computer solve the problem for a very large but finite matrix. Others suggested the following, elegant solution.

Connect a one-ampere current source between node A and infinity so that 1 ampere flows into node A. By symmetry, the current will split into four 1/4-ampere components, each of which will flow through one of the four resistors. Then

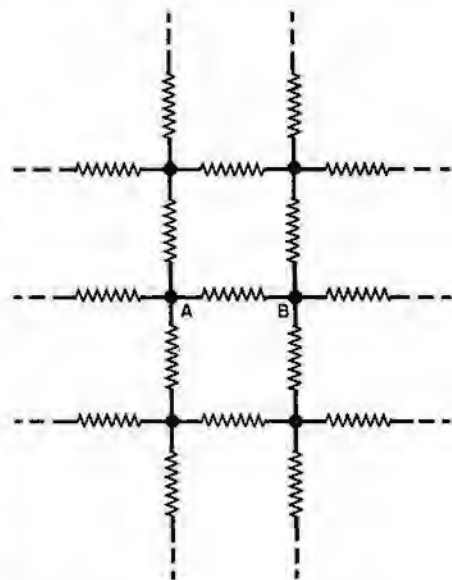

remove the current source and connect it between node B and infinity so that 1 ampere flows from node B. Again, the symmetry of the lattice dictates that 1/4 ampere will flow into node B from each of the four resistors connected to it.

The superposition theorem allows us to sum the resulting currents from both configurations. Accordingly, the current through the resistor connected directly between A and B is 1/4 + 1/4 or 1/2 ampere. By Ohm's law, the voltage across the resistor, E_{AB} , is 1/2 ampere times 1 ohm, or 1/2 volt. Ohm's law also tells us that the effective resistance between A and B is E_{AB} divided by I_T , the total current in the matrix. In this case, I_T is one ampere. Thus, R_{AB} , the effective resistance between A and B, is 1/2 volt divided by 1 ampere, or 1/2 ohm.



Product Test Reports

GENERAL ELECTRIC MODEL 3-5825

AM/SSB CB TRANSCEIVER

Features high average modulation and good noise suppression.



GENERAL ELECTRIC's Model 3-5825 AM/SSB transceiver is designed to provide total communication capability on the Citizens Band. It operates on all 40 channels and employs a digital frequency synthesis system and the now customary seven-segment LED channel display. Special features to be found in this transceiver include internal burn-out circuit protection, an antenna-failure indicator (AWI), and a quick-release mobile-mounting setup.

The transceiver also has the following complement of controls and features: RF GAIN, SQUELCH, CLARIFIER, and VOLUME controls; illuminated S/r-f meter; switchable anl/noise blanker; AM/LSB/USB mode selector; transmitter-on LED and modulation peak indicator; automatic level control (alc) and automatic modulation control (amc); HI/LO TONE switch; detachable dynamic microphone; PA operation; jacks for external speakers; bottom-facing speaker; operation from a 12-volt dc negative- or positive-ground power system; reverse-polarity protection; line filter; and electronic switching and voltage regulation.

The transceiver measures 10 5/8"D × 7 1/2"W × 2 1/2"H (27 × 19.1 × 6.4 cm). \$329.95.

Technical Details. On SSB, the receiver employs single conversion to a 10,695-kHz i-f and uses a crystal filter for selectivity and sideband selection.

Three 10,695-kHz i-f stages, two of which are direct coupled, precede the SSB product detector, while carrier injection is provided by a 10,695-kHz crystal oscillator (bfo). A second conversion to 455 kHz is employed for AM, which uses a ceramic filter for selectivity.

A diode-protected transistor stage precedes the first mixer. The second mixer, used for AM, is of the balanced-diode type. Three 455-kHz i-f stages precede the AM diode envelope detector and agc, following which is the anl that can be switched in and out simultaneously with the noise blanker. The latter employs an r-f amplifier, detector, and pulse amplifier that cause the output of the first mixer to be interrupted (gated) by the noise pulses.

The audio section, including the power-output amplifier, is incorporated into a single integrated circuit. The squelch system is a three-stage amplified system that is activated by the agc.

A phase-locked-loop (PLL) scheme is used for frequency control. It contains the usual 10,240-kHz crystal oscillator, from which the standard reference is derived. This oscillator is also used for the second conversion to 455 kHz for AM reception.

The voltage-controlled oscillator (vco) at the first mixer functions at a frequency 10,695 kHz higher than the CB signal. Its comparison signal is obtained through a down mixer and a 10,052.5-

kHz crystal oscillator and dividing setup that is controlled by the channel selector switch. This signal is applied to an IC phase comparator, along with the standard reference. The LED display consists of the usual decoder/driver circuitry.

On transmit in the AM mode, a 10,695-kHz crystal signal from the bfo is difference-mixed with the vco signal to provide the on-channel carrier. The mixer is followed by a two-stage r-f preamplifier, driver, and final power amplifier. The latter two stages are collector-modulated as usual from the audio section in the receiver, which contains automatic modulation control (amc). A multi-section output network provides impedance matching to 50-ohm loads and attenuation of harmonics.

An Antenna Warning Indicator (AWI) comes on if a short or open circuit or other malfunction in the antenna system causes a high SWR to be detected by a sensing element in the transmitter. This indicator immediately apprises the user of a problem. It functions only on AM. If the malfunction is not noticed immediately, the manual states that built-in circuit protection will permit the transmitter to be operated for up to five minutes before damage occurs.

The usual type of SSB transmitting system is used in this transceiver. It consists of a balanced modulator and crystal sideband filter, followed by the transmitter mixer, where the signal is combined with the 10,695-kHz crystal signal for USB use. This crystal signal is shifted to 10,692 kHz, along with a +3000-Hz change in the vco to set up the initial signal at the proper side of the filter for LSB use.

Laboratory Tests. The receiver's sensitivity measured 0.8 μ V for 10 dB (S + N)/N with 30% modulation at 1000 Hz on AM with a nominal 0.5- μ V signal at 6 dB (S + N)/N. In either case, it produced a maximum sine-wave audio output of 3.25 watts at less than 2% THD with a 1000-Hz test signal into 8 ohms. SSB sensitivity was nominally 0.18 and 0.1 μ V for 10 and 6 dB S/N.

Operating from the standard test source of 13.8 volts dc, the transmitter carrier output on AM was 3.75 watts. Up to 100% modulation was possible, and at microphone levels 25 dB more than needed for 50% modulation, the THD with a 1000-Hz signal was less than 2% (10% with a 400-Hz signal). Adjacent-channel splatter with 1000-Hz or voice signals was at least 60 dB down and no overmodulation was observed. The 6-dB audio response was 500 to 2400

Hz, and transmitter frequency tolerance was within ± 2 Hz of -83 Hz.

The r-f power output on SSB was 9 watts PEP using test tones and 12.75 watts PEP during voice operation. The unwanted-sideband and carrier suppression were 55 dB on USB and 60 dB on LSB. The audio response was 300 to 2800 on LSB and 380 to 3100 Hz on USB. Third-order distortion products were 29 dB below two test tones (35 dB below PEP) at 10 watts PEP, while at 12 watts PEP, they were 23 dB below test tones (29 dB below PEP). Above 10 watts PEP, some flattopping was noted, accounting for the deterioration we observed at 12 watts PEP.

The range of the squelch threshold was 0.5 to 550 μ V. The agc held the audio output level to within 8 dB on AM and 13 dB on SSB with an r-f input change of 20 dB at 1 to 10 μ V. It held to 15-dB on AM and 20 dB on SSB with an 80 dB change at 1 to 10,000 μ V. The S meter registered S9 with a nominal 50- μ V input signal.

Image rejection was 65 dB (primary) and 60 dB (secondary). I-f and other unwanted spurious-signal rejection measured greater than 80 and 60 dB, respectively. AM adjacent-channel rejection and desensitization was 58 dB mini-

mum. Unwanted sideband suppression was at least 60 dB at 1000 Hz. The 6-dB audio response was 575 to 1600 Hz on AM and 600 to 2000 Hz on SSB (the clarifier control works only on SSB receive), with the upper end extending 300 to 400 Hz higher with the tone control set to HI.

User Comments. As our measurements indicate, receiver sensitivity, selectivity, and unwanted-signal responses, plus the use of the r-f gain control, provided good reception under adverse conditions. The ANL/NB combination enhanced receiving performance, with our lab tests showing that the original S/N versus sensitivity was maintained in the presence of impulse noise 100 dB above 1 μ V/MHz bandwidth. Vehicle tests were also excellent.

We obtained good quality and high audio output power even with weak r-f signal levels. Use of the tone control let us set up the sound to suit our own taste. In this respect, the HI tone position provided us with the best intelligibility. On the other hand, the LO position helped to minimize noise.

The transmitter performed nicely, providing high average modulation levels without overmodulation or adverse splatter. The excellent unwanted-side-

band suppression on SSB made dual-channel operation (simultaneous use of one frequency with two separate conversations, one on LSB and the other on USB) possible without interference between the two.

The transceiver is enclosed in a well-shielded case. The rotary controls are clearly identified and convenient to use. The mode and channel selector knobs have grip bars for easy operation. We particularly like the mode switch setup at the top of the panel, with the center position for AM and the LSB and USB positions to the left and right.

Another nicety is that the clarifier control has ± 1 to ± 5 calibration points, with a detent at the center position. This makes for quick retuning.

The edgewise meter is somewhat easier to read than is usually the case. Miniature toggles are used for switching some functions, such as the tone control (which has fixed HI and LO settings).

Aside from good overall performance and convenient handling, the transceiver offers the mobile user the advantages of SSB for enhanced CB communication. Of course, the inclusion of AM operation allows the user to communicate where the "other" station is not equipped for SSB.

CIRCLE NO. 103 ON FREE INFORMATION CARD

ARIES SYSTEM 300 ELECTRONIC MUSIC SYNTHESIZER

Has five-octave keyboard and 12 functional modules.



THE ELECTRONIC music synthesizer has added a whole new dimension to modern music. The basic characteristic that sets it apart from other musical instruments is flexibility. A synthesizer can produce almost as many different sounds as the player can imagine. That's why electronic music comprising many synthesizer tracks is so dramatic, and why many rock bands now use the synthesizer as a primary keyboard instrument.

The Aries System 300 is a two-voice, modular electronic music synthesizer. It has a five-octave keyboard with key-

board interface and 12 functional modules: two envelope generators; voltage-controlled amplifier (vca); two voltage-controlled oscillators (vco's); voltage-controlled filter (vcf); dual low-frequency oscillator/lag/inverter; sample-and-hold/clock/noise generator; balanced modulator; dual mixer; power supply; and an audio output/power control module. Cases, keyboard, and modules are available separately (see box). The keyboard in its case measures 43"L x 10"D x 4"H (110 x 25.4 x 10.2 cm) and the synthesizer cabinet measures 34½"L x 10"H x 10"D (88 x 25.4 x 25.4 cm).

General Description. At the heart of the System 300 synthesizer is the AR-317 voltage-controlled oscillator (vco) module. It produces and simultaneously provides four waveforms at amplitudes of 10 volts peak-to-peak. The ± 5 -volt sine, sawtooth, and triangle waves are centered on a 0-volt reference, while the variable-width pulse output oscillates between 0 and 10 volts.

Exponential circuitry provides 1-volt/octave (1/12-volt/semitone) control over a very wide range. Two potentiometers and a RANGE switch permit manual control from 0.03 to 30 Hz and from 16 to 16,000 Hz. External control voltages can determine the output frequency over a 0.002-to-50,000-Hz range. Four control inputs, one with a level control, are provided. The control inputs are summed so that each +1-volt input doubles and each -1-volt input halves the output frequency. Inputs are also provided for pulse-width modulation and frequency syncing with an external square-wave or pulse generator.

The basic waveform produced by this

module is the triangle. Its frequency is determined by an exponential current source varied by the control inputs. The source provides charging current for timing capacitors selected by the RANGE switch. A loop composed of two operational transconductance amplifiers, a complementary pair of bipolar transistors, and a JFET generate the triangle waveform.

The triangle wave is buffered and presented at the appropriate output jack. It also drives an open-loop op amp and a waveform converter circuit, which results in variable-width (5% to 95%) pulse and sinusoidal outputs. The sawtooth is generated by a separate loop driven by a secondary output of the exponential current source. This sawtooth circuit is pulse synchronized to the main oscillator loop.

The AR-312 envelope generator produces a 0-to-10-volt signal that is normally used as a control input for a vca or voltage-controlled filter (vcf). The ATTACK, DECAY, SUSTAIN, and RELEASE controls shape the output waveform. When a positive gate signal is applied to the input, the envelope generator can accept trigger pulses. Upon receipt of a trigger pulse, the generator's output in-

creases exponentially from 0 to 10 volts, at a rate determined by the setting of the ATTACK control. The attack time is variable from 2 ms to 4 s. A level detector conducts when the output reaches 10 volts, causing the main timing capacitor to discharge at a rate determined by the setting of the DECAY control. The output voltage decays exponentially until it equals a threshold selected by the SUSTAIN control and remains at this level until the gate signal is removed. When this occurs, the output exponentially decays to 0 volt at a rate determined by the setting of the RELEASE control.

Four outputs (wired in parallel) and two gate and trigger inputs are provided. Pressing a MANUAL GATE switch activates and triggers the envelope generator. When the button is released, the output signal decays to ground. This module also includes a four-jack, front-panel patch point.

Dynamic control of an audio signal is performed by the AR-316 vca, which is designed around a CA3080 operational transconductance amplifier. One of two op amps sums four control inputs (one with an attenuator); the other serves as an output gain stage. Setting the MODE switch to LIN causes the vca's gain to be

determined by the ratio (control voltage)/10. In the EXP position, the gain is determined by the formula $\text{gain (dB)} = 10(V - 10)$, where V is the control voltage in volts. This allows a 10-dB/volt control.

Four audio inputs, two of which are connected by level controls, can be applied and summed by the CA3080. An INITIAL GAIN control acts as a front-panel master gain control. Depending on its setting and the magnitude of the control inputs, the gain will vary from -100 to 0 dB. The vca can handle audio inputs up to ± 10 volts peak and control inputs up to +10 volts maximum.

Control over the tonal characteristics of synthesizer waveforms (and those of other electrical musical instruments) is furnished by the AR-327 multimode vcf. Audio input signals are summed by an op amp mixer and passed through one or more active filters. Control inputs are mixed by another op amp, whose output drives an exponential generator module. The module controls op amps that set the frequency response of the active filters. Low-pass, high-pass, band-pass, and peak/notch outputs are available simultaneously. (The notch or peak mode is switch selectable.) Response is 12

Listen to what the world is saying. . .

THE YAESU FRG-7 MARK II. . .

ACCLAIMED THE FINEST ALL-BAND RECEIVER IN ITS PRICE CLASS. . .AND MORE!



Professional critics have been loud in their acclaim for the YAESU FRG-7 solid state synthesized 500 kHz to 29.9 MHz all band receiver. Triple-conversion, the AC, 12V DC, or flashlight battery operated receiver provides exceptional sensitivity, dial accuracy and rock-like stability of reception. Mate it with the YAESU QTR-24 world time clock and you'll know the exact time, night or day anywhere! Try it at your YAESU dealer or write for full information. . .NOW! (UL approved)



QTR-24
World Clock

**Dealer
Inquiries
Welcomed**

YAESU
The radio.



Yaesu Electronics Corp., 15954 Downey Ave., Paramount, CA 90723 ■ (213) 633-4007
Yaesu Electronics Corp., Eastern Service Ctr., 613 Redna Ter., Cincinnati, OH 45215

dB/octave, and Q is adjustable from 0.5 to 512 by means of a RESONANCE control. One audio and one control input are connected to front-panel attenuators.

Exponential control, an important vco feature, is also provided. The cut-off frequency of the filter increases one octave for each +1-volt increase of the control input and decreases one octave for each -1-volt increase. A FREQ control, together with any control inputs, determines the cutoff frequency over a 16-to-16,000-Hz range.

Three modules contain independent circuits that perform separate functions. The AR-324 module has two low-frequency oscillator's (lfo's) that simultaneously provide ± 5 -volt triangle, 0-to-10-volt sawtooth, and 0-to-10-volt square-wave outputs over a frequency range of 0.3 to 30 Hz. The oscillators can be synchronized to an external pulse or square-wave generator by means of a SYNC input. As in the vco, the sawtooth is generated independently. Differentiated pulses from the square-wave circuit control the discharge of the capacitor across which the sawtooth is developed. Thus, the sawtooth is synchronized to the other waveforms.

The lag circuit in this module is essentially a low-pass filter. A potentiometer determines the time constant (1 ms to 1 s) of an RC circuit. The output of the lag is buffered by a unity-gain voltage follower. Also included in the module is a variable-gain inverter. Inputs are coupled to a standard op-amp inverter through a variable attenuator. The maximum voltage gain is -1. Both the lag and inverter can handle peak signals of ± 10 volts.

The second multifunction module is the AR-318 sample-and-hold/clock/noise generator. When a positive-going pulse is applied to the trigger input of the sample-and-hold circuit, a FET switch turns on and allows a capacitor to charge up to half the instantaneous signal voltage. (The input is passed through a 2:1 attenuator.) The switch then turns off to prevent the capacitor from further charging or discharging.

A FET op amp output buffer multiplies the capacitor voltage by two and presents it at the sample-and-hold output. When a positive signal of at least 2 volts is applied to the GATE input, the FET switch is kept on continuously. In this "track-and-hold" mode, the input follows the output exactly. If the gate signal is removed, the output remains at the instantaneous signal voltage at the time of removal. The circuit can also be activated by a MANUAL TRIGGER switch.

The clock is a voltage-controlled, low-frequency oscillator with 0-to-10-volt sawtooth, square-wave, and trigger (narrow pulse) outputs. The frequency range is 0.3 to 30 Hz. Inputs are provided for frequency modulation and syncing to an external pulse or square-wave source. A switch allows either the clock or an external source to provide trigger and gate signals for the sample-and-hold circuit.

The third function of this module is to provide three noise signals. White noise is developed by amplifying and filtering the output voltage from a reverse-biased transistor junction. Pink noise is obtained by passing the white noise through a -3-dB/octave low-pass active filter. The pink noise is rectified, filtered, and amplified to create a slowly varying random waveform. The random and pink-noise outputs are 4 volts rms, with equal energy per cycle between 0.4 and 7 Hz and equal energy per octave between 16 and 16,000 Hz, respectively. The 7-volt rms white-noise signal has equal energy per cycle between 16 and 16,000 Hz.

The AR-315 module contains a balanced modulator and two general-purpose attenuators. The balanced modulator has X and Y inputs. Signals applied to these inputs are fed to a four-quadrant multiplier IC whose output drives an op amp in the differential mode. When the circuit is properly trimmed, the output voltage is $XY/10$, where X and Y are the input signal levels in volts. If either or both inputs is zero, the output is zero. The levels can be independently controlled for each input. The two attenuators in the module can be used at any point in a synthesizer patch.

Signal summing is performed by the AR-323 dual mixer. Each mixer has four inputs, two of which have polarity selection switches and level controls. This allows both addition and subtraction of audio signals, envelopes, etc. Outputs are provided for the A and B mixer separately, as well as combined A + B and A - B. These allow the module to be used as a single eight-input mixer. Six op amps are used for signal summing and inverting. Maximum signal levels are ± 10 volts.

The voltages required by the various modules in the system (+5, +15, -15 volts) are supplied by the AR-322 power supply module. IC voltage regulators, large heat sinks, and electrolytic capacitors are used in the module. The three current-limited (1-ampere) output voltages are available at three parallel-wired octal sockets.

The AR-326 output and power control module switches ac from the line to the power supply and contains two independent audio output amplifiers. The amplifiers are each mounted on separate pc cards and consist of an op amp driver and a complementary pair of transistors operating in class AB. The output signals are routed to a headphone jack and two output phono jacks. The module can drive headphones, high-impedance (40 ohms or more) speakers, or power amplifiers. Two four-jack patch points are provided as are jacks at which +10 and -10 volts are available. The power supply's ac line switch and pilot light are mounted on the front panel of the AR-326 module.

All of the modules described so far mount in the AR-310 cabinet. Eleven modules (all but the power supply) have front panels and all of these except the output power and control module plug into 22-pin edge connectors, which bus power from the power supply module.

Patching can be accomplished in one of two ways. First, patch cords terminated with miniature phone plugs can be inserted into front-panel jacks. This allows the user to make hundreds of different patch combinations according to his own ideas of how the synthesizer should be used. Alternatively, all inputs and outputs at the edge connectors can be hard-wire patched, or limited-patch switching can be developed via the edge connectors.

Also included in the System 300 are the AR-311 keyboard, AR-313 keyboard interface, and AR-320 keyboard case. The preassembled keyboard has 60 precision resistors that form a voltage divider. One set of gold-plated key contacts connects a specific tap on the voltage divider to the keyboard voice bus. The voltage on this bus depends on the specific key depressed. The lowest key produces 0 volt and the highest, five octaves away, produces 5 volts. Each ascending key produces an 83.3-mV increase over the key to the left, resulting in 1 volt/octave voicing.

The keyboard voice voltage tracks the lowest key depressed. However, another "auxiliary voice" voltage is developed when two keys are pressed simultaneously. The magnitude of this voltage depends on the keyboard interval created by the two keys. A second set of gold-plated contacts is used to generate gate and trigger signals.

The AR-313 keyboard interface produces four output signals. The GATE signal is at +10 volts and remains on as long as any key is held down. The TRIG-

GER output is a ± 10 -volt, 1-ms pulse that appears each time a key is pressed. The VOICE output is a dc voltage that is proportional to the lowest key held down. It remains at its last level after the key is released.

When the interface is properly tuned and trimmed, the lowest key (C) produces a 0-volt "voice" signal. The C# key produces 83.3 mV, etc. Hence, each octave adds one volt, which raises the output frequency of the vco by one octave. The "aux voice" output appears only when more than one key is pressed at the same time. Its voltage is proportional to the interval between the highest and lowest keys depressed. When one or no key is depressed, this output is 0 volt.

The interface's TUNING control adds or subtracts voltage from the VOICE output over a 1.5-octave range. It has no effect at or near its center position. Glide or slur from one key to the next is provided by the portamento circuit. The PORTAMENTO control determines the glide time that is essentially independent of the keyboard interval in the NORMAL mode. In the LINEAR mode, the glide takes longer for larger intervals. Placing

ARIES SYSTEM 300 ELECTRONIC MUSIC SYNTHESIZER	
AR-311 Keyboard	\$119.00
AR-313 Keyboard Interface	87.00
AR-320 Keyboard Case	48.00
AR-312 Envelope Generator (2, each)	55.00
AR-327 Multimode VCF	149.00
AR-316 VCA	63.00
AR-315 Balanced Modulator and Attenuators	62.00
AR-317 VCO (2, each)	115.00
AR-318 Sample-and-Hold/Clock/ Noise Generator	59.00
AR-323 Dual Mixer	65.00
AR-324 Dual LFO/Lag/Inverter	65.00
AR-322 Power Supply	92.00
AR-326 Output and Power	59.00
AR-310 Synthesizer Cabinet	89.00
System Price (Kit form)	1195.00
System Price (Assembled)	1895.00

the PORTAMENTO switch in the OFF position disables the circuit.

The AUX TRIM and VOICE TRIM are front-panel screwdriver-type controls that are used to set the output intervals to 1 volt/octave. After initial adjustment, they need not be disturbed.

Assembling the Kit. This is a fairly complex kit to assemble. Actually, it is a collection of mini-kits. Each of the modules can be assembled and tested independently. After completing the power supply module, we put together the synthesizer cabinet from precut lumber. Then we installed the power supply and edge connectors to be ready for each of the other modules.

Next, we assembled the keyboard, keyboard interface, and keyboard case. The keyboard case comes precut and drilled, and the keyboard itself is preassembled. The interface circuitry is housed on two printed circuit boards. The interface boards (as well as those in the other modules) are not silk screened with component locations, but assembly was not difficult because larger-than-life parts placement diagrams were provided with the instructions.

wire wrapping center

<p>NEW HOBBY WRAP MODEL BW 630</p> <p>Battery wire wrapping tool</p> <p>\$34.95 <small>ONLY</small> COMPLETE WITH BIT AND SLEEVE</p>	<p>STRIP / WRAP / UNWRAP MODEL WWSU-30</p> <p>\$5.95*</p>	<p>RIBBON CABLE ASSEMBLY</p>	<p>DIP SOCKETS</p>
<p>DIP IC INSERTION TOOL WITH PIN STRAIGHTENER</p> <p>MODEL INS-1416</p> <p>\$3.49*</p>	<p>WIRE DISPENSER MODEL WD-30-B</p> <p>\$3.45*</p>	<p>PRE-CUT PRE-STRIPPED WIRE</p>	<p>WIRE WRAPPING KIT</p> <p>\$15.45*</p>

*MINIMUM ORDER \$25.00, SHIPPING CHARGE \$1.00. N.Y. CITY AND STATE RESIDENTS ADD TAX

OK MACHINE AND TOOL CORPORATION

3455 CONNER STREET, BRONX, NEW YORK, N.Y. 10475 U.S.A.
PHONE (212) 994-6600 TELEX NO. 125091

With two exceptions, each Aries module worked perfectly the first time it was powered. One was due to a wiring error. The other was a result of a marginal circuit's design given tolerance of parts. Trouble was experienced with the dual Ifo's. Correct waveforms were obtained at the square and triangle wave outputs, but a +10-volt level appeared in place of the sawtooth outputs. Aries was contacted for advice by telephone. Following a few suggestions from Jim Bastable (now one of the Aries partners), the beginnings of a sawtooth appeared.

Further experimentation on our and Aries' parts resulted in a solution to the problem, which involved a few changes in component values. Aries has modified the circuit in line with our results, and informed us that although previous module purchasers had not contacted them about the sawtooth, they would all be informed of the change.

We performed the various circuit adjustments with the aid of a multimeter, frequency counter, and oscilloscope. These instruments are not absolutely necessary for making the adjustments, but they do make them easier to perform and yield accurate results. Easy-to-follow trim instructions are provided with each module.

The last part of assembly was to finish the wood that makes up the two cases. This is an option left to the builder's tastes, but it is well worth the effort, since it results in an instrument that looks as good as it sounds. Two coats of stain and then two coats of polyurethane were applied to all exterior surfaces of the keyboard and synthesizer cabinets.

Total assembly time for the System 300 was about 95 hours, not including the three hours or so required for trimming adjustments. We noted during assembly that all components supplied were of high quality. In many cases, components with tolerances closer than specified in the parts lists were supplied.

User Comment. Modern electronic music synthesizers fall into two categories, performance types and studio types. The performance synthesizer is polyphonic, computerized, and looks like and is played in a manner similar to an electronic organ. The studio synthesizer, on the other hand, is usually monophonic or has two- or three-note chord capabilities. Most studio synthesizers are made up of combinations of different modules that are designed to be interconnected as required by jacks and patch cords. With this type of instrument, the musician has a more deliber-

ate, subtle control over each note he generates. He can patch as conditions require. As each note is generated, he can record it and, at the end, perform a mix-down to obtain the final "composition."

The Aries System 300 is decidedly a studio synthesizer. It looks solid and substantial. More importantly, it sounds as good as it looks.

The fact that this is a kit and is modular in design gives the user a wide range of possibilities for designing the instrument to meet his own specialized needs.

We were impressed with the way Aries has covered the classical spectrum of function modules in the System 300. As laid out, the system gives the musician a practically infinite palette. Each of the modules that make up the system performed with clean precision, and we were unable to exhaust the patch combinations possible.

On the negative side, we found the control parameters to be too husky and too responsive. We would have preferred to be able to spread the control over a larger, smoother range. For example, the amplitude of a control signal applied to the vco for vibrato (frequency modulation) had to be cranked down to the very threshold of the input level control to be within acceptable limits. We could have passed the control voltage through one of the two attenuators and thence to the input level control, but that would have been awkward and wasteful.

A similar problem was noted with the noise generator. It would have been preferable if the noise generators had had built-in attenuators because noise is seldom used at full volume. Patching the noise signal from its source to an attenuator and then to another module is a nuisance. In short, the Aries synthesizer is a bit too spunky, and it has too many muscles.

For us, the ultimate test of any synthesizer is in musical composition, using multitrack overdubbing. We usually try to construct a piece in four stages, using simul-sync on a 4-track tape recorder. Using the System 300, we began by patching up an automatic percussion rhythm, using white noise and a sine wave at low audio frequency. The sampler module was used to control the filter's cutoff frequency. (Signals were taken from the filter's bandpass output.) The pulse output of a low-frequency oscillator was used to trigger the envelope generator. The result was a pseudo bass drum and brushed cymbal. The drum, controllable from the keyboard, was played as a bass line rhythm on the

first track of the 4-track tape recorder.

Next, we set up and played a chromatic cymbal on track two to complement the walking bass. Then a voice patch with an envelope and vibrato that approximated the human voice was recorded on track three as a melodic figure manipulated in conventional ballad fashion. Finally, a supporting contrapuntal line was added, using a stringy sound. When we were through, we were pleased with the result. The Aries system had accomplished everything we asked of it.

In sum, the Aries System 300 is for serious music and meticulous recording applications. It was obviously designed by an engineer who takes pride in his craft. The system may be a bit complicated and clumsy to program, but then it is definitely not a toy. However, we learned at press time that another model, using the same internal design, will be available to permit one to override the patch-cord interconnect system at will. This would give the option of using the unit as a highly flexible studio synthesizer or as a "live" performance synthesizer with less control flexibility. So it is possible, you see, to have your cake and eat it, too.

(The User Comments in this report were prepared by Robert A. DeVoe, Professor of Education at Fairleigh Dickinson Univ. in New Jersey. Mr. DeVoe has conducted radio and classroom courses in the Humanities and Electronic Music and is an accomplished composer of electronic music. His work has won the Armstrong award for excellence in FM broadcasting and the John Hay Fellows Award in Humanities. He is also the author of *Electronmusic: A Comprehensive Handbook*, published by Electronic Music Laboratories, Inc., Box H, Vernon, CT 06066.)

CIRCLE NO. 104 ON FREE INFORMATION CARD



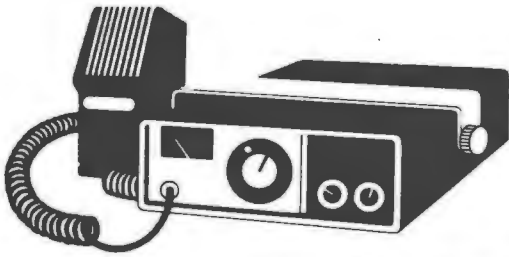

CB Scene

By Ivan Berger

BETTER EMERGENCY SERVICES ARE NEAR

THE ODDS on someone's hearing when you call for help on Channel 9 are going up. The government is raising them. And you can help.

The government's goal is to knit together law-enforcement officials, medical and emergency services, automobile clubs and such volunteer CB monitoring groups as REACT and ALERT into a network which will put every CB-equipped car in the country within reach of fast emergency assistance. To implement that goal, a new program has been set up that's called National Emergency Aid Radio, or NEAR.

Independent efforts at coordinating CB with emergency services have been going on successfully for years, of course. REACT and the other monitor groups, for example, have teams to listen to Channel 9 in systematic shifts, so that there is always someone there to hear and relay calls for help. Several states have equipped their highway patrol cars with CB. Some Smokeys have even equipped their official vehicles at their own expense.

The results have been impressive. Where the police are equipped to hear them, CB'ers now often report to Smokey, telling him of reckless drivers, accidents, traffic jams, hazardous conditions and other emergencies. Such experiences doubtless helped the Department of Transportation's National Highway Traffic Safety Administration (NHTSA) to recognize CB radio communication as "the only existing method convenient to the public at large by which the motorist can enter the response system from his vehicle," and to set up NEAR.

The program will be federally funded, but must be implemented by the individual states. That leaves it up to each

state to decide how it will allocate its NEAR funds: to buy CB equipment for local police and emergency services, to set up public information programs, to train CB monitors in emergency reporting procedures, and to pay the costs of administering NEAR. States may even elect not to participate at all.

Those states which do participate will be assigned easily-recognized call signs for use in legally communicating with other CB operators. These call signs will consist of the letter "K," the state's two-letter abbreviation, and the number 0911—"KNY-0911" for New York, for instance, or "KCA-0911" for California. (Since each state government is a single licensee, all its CB units share a single call sign.)

No money is allocated for direct use by volunteer monitors. However, there are ways that they can benefit indirectly. Local or state governments can set aside space in government facilities for volunteers' use, and may even provide equipment there. But the equipment will remain the government's, not the volunteers'. NEAR funds can also cover expenses directly relating to monitoring activities, such as long-distance telephone calls made in response to emergencies.

Where groups like REACT will benefit directly is in closer contact between government and volunteers. We understand that each state *must* collaborate with volunteer monitors (and with other volunteer groups, such as Civil Defense) in setting up a NEAR Advisory Council and a NEAR plan. Without such collaboration, the state won't qualify for Federal NEAR funds.

The volunteer monitor groups must meet several criteria, though. For instance, they must be primarily devoted to emergency communications monitor-

AVANTI® HIGH PERFORMANCE C.B. ANTENNAS

40 CHANNEL ENGINEERED

ASTRO PLANE™ CB Base Antenna Co-inductive

The omni-directional CB antenna that radiates from the top — for greater range and performance. 4.46 db gain over isotropic — stronger signal, clearer reception. No coils to burn or short. Vertical polarity. Patent #3587109
Model AV-101...price \$39.95
2.8x more power
E.R.P.

Avanti CB base antennas
from \$20.50 to \$404.00



RACER 27™ CB Mobile Antenna Magnetic mount

Easy to mount on roof or trunk for car, van or truck — no holes to drill — fast removal for hide away or car washing. Strong magnet assures position. Mylar pad guards vehicle finish.

Hermi-coil (Hermetically sealed coil) — A special molding process provides a weather-proof coil environment. Helps maintain the characteristic antenna impedance, even in damp or salt water atmosphere. Hermi-coil also helps eliminate internal surface leakage.

Ribbed base — Provides a long leakage path used in high voltage insulators, spark plugs, etc.

Specifications: Electrical 1/4 wave length
● Unity gain ● 27 MHz
● V.S.W.R. — 1.3:1 or better
● Coil — shunt fed hermicoil

MODEL AV-727 Mobile Antenna System with 48" whip, 17' coaxial cable with magnetic mount. 40 channel \$32.95

Avanti makes a complete line of high performance mobile CB antenna systems from \$11.95 to \$72.50



FREE 24 PAGE CATALOG

avanti

Avanti Research & Development, Inc.

Established 1964

340 Stewart Ave., Addison, IL 60101 USA

creators of the
famous



© Copyright 1977.
All rights reserved

CIRCLE NO. 8 ON FREE INFORMATION CARD



**Before
you buy
stereo
headphones,
get
some
good
advice.**

Theirs:

Julian S. Martin
HI-FI STEREO BUYERS' GUIDE, March-April, 1976

"Superb from every viewpoint. An outstanding achievement in headphone design. One of the most comfortable."

The Len Feldman Lab Report
TAPE DECK QUARTERLY, Winter, 1975

"Response of these phones extends uniformly from 20 Hz to over 22,000 Hz with no more than ± 2 dB variation over this entire range...this is nothing short of incredible."

New Equipment Reports
HIGH FIDELITY, January, 1976

"The sound quality the AT-706 presents [to you] is exceptional: very wide range and smooth...Within this excellent operating range the sound is exceedingly clean and open...an extremely fine stereo headset."

If you asked the critics they'd tell you to listen critically to a variety of products before you buy. We agree. Because the more carefully you listen, the more you'll be impressed by the sound of Audio-Technica.

AT-706

Electret Condenser
Stereo Headset \$129.95
Our finest Personal Transducer



audio-technica.

® INNOVATION □ PRECISION □ INTEGRITY

AUDIO-TECHNICA U.S., INC., Dept. 107P, 33 Shiawassee Avenue, Fairlawn, Ohio 44313
Available in Canada from Superior Electronics, Inc.



ing, have demonstrated their capabilities and earned community support, and have state or national affiliations.

Independent monitoring will still be encouraged. NEAR funds spent on public information and education will probably result in more and more CB users' learning what Channel 9 is for and how to use it. This part of the program has already borne some fruit. It's a handy, common-sense book called the *Citizens Band Monitor Guide*. Some of its hints and reminders struck are especially worth noting.

Four C's. The book stresses the four "C's": an effective NEAR monitor should be Calm, Courteous, Correct and Concise. The book gives some specific tips on how to accomplish this:

- "The monitor must remain the link between the need and the help until that help arrives. That includes getting and relaying further information from the caller, and relaying or giving advice on life-saving or other emergency procedures that the caller may be able to handle in the meantime.

- "Keep in mind that most calls for help come from a place of stress. The caller may be excited, shaken, alarmed, frantic and even hostile. Your job is to remain clam and instill calm and confidence in your caller. . . . However, you should *not* tell him to 'calm down.' This will only make him think you don't appreciate the seriousness of the situation."

- The *Guide* gives two pages of suggestions on how to deal with such common and uncommon emergencies as aircraft accidents, fires, lost children, stalled cars and tornados. For each of 26 such incidents, it suggests what information a monitor should elicit from the caller, which government services should be alerted, and what special instructions should be relayed back to the caller. (Oddly, I noticed no sign of another common-sense suggestion: that the phone numbers of all these services should be kept at the monitoring station.)

- 10-codes are listed in large type, for easy reading. But the *Guide* also points out that "You should *never* use 10-codes with parties who would not understand them," though "you should be able to understand them, nevertheless."

- Get the information in a regular sequence. You can't ask everything at once, and you have to ask important things first." The book suggests one possible such sequence: first ask the nature of the problem, then the caller's

location and phone number (if applicable), then the specific location of the incident, the caller's name, and more details of the incident itself.

● "Explain why it will take time to check for information, and that you will call back. A party waiting on a 'dead phone' may become irritable and uncooperative."

● To simplify evaluation of the NEAR program's effectiveness, a monitor logbook designed for input to a computer will be made available. This will be for use only by Monitor Base Stations designated by State CB NEAR Programs. Data to be filled in includes the time delay between occurrence of the incident and notification, nature of the incident, type of response agency notified, and the time the action was completed, as well as identification of the calling source and the monitor unit.

● Monitors should be able to identify an emergency's location even when the caller is a stranger to the area. The *Guide* suggests that monitors equip themselves with road, street and topographical maps and guides.

● Monitors should use words and phrases that are easy to transmit and understand, should avoid local jargon which callers en route through the area might misunderstand, and should speak slowly and clearly.

● For clarity, it's wise to learn the International Phonetic Alphabet (Alpha, Bravo, Charlie, Delta, etc.), but not to overuse it. If reception is clear and the name is common, it's enough to relay it as 'S-M-I-T-H, Smith.' You don't have to slow it down to "Sierra, Mike, India, Tango, Hotel."

A NEAR monitor log has been designed, too, that's divided into sections: (1) identification, (2) incident, (3) location, (4) notification source, (5) action taken. The latter's time is to be expressed in 24-hour clock time. The forms can be produced locally for distribution to monitors. Interestingly, forms can be used for input to a computer so that information can be readily extracted. Number codes are used throughout, even for the type of emergency.

If you'd like to read the whole *Citizens Band Monitor Guide*, it's available for 80¢ a copy (\$1.00 minimum on mail orders) from the Superintendent of Documents, U. S. Government Printing Office, Washington, DC 20402. Order Stock No. 050-003-00235-6.

You can also find out who's working on NEAR in your state by contacting REACT, 111 E. Wacker Dr., Chicago, IL 60601. ◇

FREE

McIntosh CATALOG and FM DIRECTORY

Get all the newest and latest information on the new McIntosh Solid State equipment in the McIntosh catalog. In addition you will receive an FM station directory that covers all of North America.



MX 113

FM/FM STEREO - AM TUNER AND PREAMPLIFIER

SEND TODAY!

McIntosh Laboratory, Inc.
East Side Station P.O. Box 96
Binghamton, N.Y. 13904
Dept. PE

NAME _____
ADDRESS _____
CITY _____ STATE _____ ZIP _____

If you are in a hurry for your catalog please send the coupon to McIntosh.
For non rush service send the *Reader Service Card* to the magazine.

CIRCLE NO. 37 ON FREE INFORMATION CARD

BYTE

The Small Systems Journal

Isn't it time you had your own personal computer?

Read **BYTE**, the leading consumer publication covering the fantastic new field of personal computer applications. Today, large scale integration has made it possible for the individual to enjoy the unique benefits of a general purpose computing system. Now, an entire micro industry markets microcomputer related items, products that range from computer system kits to peripherals, software and literature on the subject. But where should you go for all the details about your personal involvement in computer technology?

Read **BYTE**, the Small Systems Journal devoted exclusively to microcomputer systems. Every issue a monthly compendium of lively articles by professionals, computer scientists, and serious amateurs.

Fill in subscription coupon today, or phone your request directly — call 617/646-4329 and ask for your subscription. Read your first copy of **BYTE**, if it's everything you expected, honor our invoice. If it isn't, write 'CANCEL' across invoice and mail it back. You won't be billed and the first issue is yours.

Allow 6 to 8 weeks for processing.

BYTE

BYTE Subscriptions Dept. 07C
P.O. Box 361
Arlington, Mass. 02174

Please enter my subscription to **BYTE**...

\$12 One Year \$22 Two Years \$32 Three Years
 Bill me Check Enclosed
 Bill BankAmericard Bill Master Charge

Credit Card Number

Credit Card Expiration Date _____

Name (Please Print) _____

Address _____

City _____ State _____ Zip _____

CIRCLE NO. 10 ON FREE INFORMATION CARD

Heathkit®

FALL 1977

New

THE HEATHKIT COMPUTERS

The "total system" computer products for home, hobby, educational and business applications. With powerful software to get you up and running fast, superior documentation and service support, sensational low prices too. They're the ones you've been waiting for! See pages 2-11.



H8 8-Bit Digital Computer, pages 4-5



H9 Video Terminal, page 9



H11 16-Bit Digital Computer, pages 6-7

H10 Paper Tape Reader/Punch, page 8

Plus the world's largest selection of quality easy-to-build electronic kits

Heath-recommended electronic products



Video Recorder, page 59



Telephone Answerer, page 76



Electronic Chess Game, page 77



Indoor Greenhouse, page 78

© 1977 Heath Company
See index on page 2

New Kit Products for FALL



Active Audio Processor, page 39



Low-Priced Oscilloscope, page 68

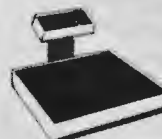

Electronic Digital Scale, page 104



PET Multimeter, page 99

HEATHKIT MAIL ORDER CATALOG 81

"Heath" and "Heathkit" are registered trademarks of Heath Company

Heath Company, Dept. 010-330
Benton Harbor, Michigan 49022

POPULAR ELECTRONICS

FREE!

The NEW Heathkit catalog introducing our complete line of personal computers and many more, exciting, fun-to-build electronic kits

NEW! H8 8-Bit Digital Computer

This 8-bit computer based on the famous 8080A microprocessor features a Heathkit exclusive "intelligent" front panel with octal data entry and control, 9-digit readout, a built-in bootstrap for one-button program loading, and a heavy-duty power supply with enough capacity for plenty of memory and I/O interfaces. It's easier and faster to use than most other personal computers and it's priced low enough for any budget.

NEW! H11 16-Bit Digital Computer

Heath, the world's largest kit manufacturer, and Digital Equipment Corporation, the leader in minicomputer systems, combine to bring you today's most sophisticated personal computer. Features include DEC's 16-bit LSI-11 CPU, 4096 x 16 read/write MOS memory expandable to 20K (up to 32K words total), priority interrupt, DMA operation and more. Complete systems software for fast and efficient operation is included!

NEW! H9 Video Terminal

This full ASCII terminal system features a bright 12" CRT, with both long and short-form displays, all standard serial interfaces, plus a fully wired and tested control board. Has auto-scrolling, cursor with full positioning controls, full-page or line-erase modes, a transmit page function, and a plot mode for simple curves and graphs. The H9 is compact, attractive and easy to build. It's compatible with all Heathkit computers as well as most others through standard interfacing.

NEW! H10 Paper Tape Reader/Punch

Complete mass-storage peripheral using low-cost paper tape. Features a solid-state recorder with stepper motor drive, totally independent punch and reader modes and a copy mode for fast, easy tape duplication. Reads at 50 characters per second, punches at 10 characters per second. For use with Heathkit computers and most others.

Other Heathkit computer products include a cassette recorder/player for mass storage, teleprinter, self-instructional programming courses, a complete library of the latest computer books, plus software, memory expansion cards, I/O cards and lots more — everything you need to make Heath your personal computing headquarters!

NEW! Kit products for fall

An exciting selection of new kits includes an active audio processor to give your present hi-fi system better dynamic range and reduced noise levels, a new medium-power stereo FM-AM receiver, an electronic digital scale that shows you weight in big, bright easy-to-read numbers, and new test instruments including a low-priced precision oscilloscope and an easy-to-use FET multimeter.

NEW! Heath-recommended electronic products

These unique new products are recommended by Heath because of their excellent quality and outstanding value. The Sony Betamax™ videotape recording system using exclusive ultra-compact 2-hour Sony cartridges; an electronic greenhouse with automatic temperature and humidity controls; a microcomputer based electronic chess game; and a sophisticated multi-cartridge microprocessor-based video game. All are high quality, fully assembled, tested and priced low to give you the kind of value you expect from Heath.

PLUS nearly 400 other superb, easy-to-build, money-saving products. You'll find a complete line of digital electronic clocks and weather instruments, plus useful and unique items for your car, home or office.

There are many more exciting products to read about too! Home convenience items like a practical freezer alarm, a touch-control light switch, intercoms and a unique programmable doorbell. Automotive instruments and accessories, marine equipment, model aircraft Radio Control gear, security systems and more. Plus our world-famous Amateur Radio equipment and test and service instruments.

These are among the nearly 400 quality, fun-to-build kits described in this new Heathkit catalog. Kits for every interest. All with the world-famous Heathkit assembly manual — a step-by-step instruction guide that makes kitbuilding easy and leaves nothing to chance. And all backed by our "We won't let you fail" promise. Find out about the satisfaction, savings and FUN of kitbuilding.

**Send for your
FREE copy today!**

HEATH Schlumberger	Heath Company, Dept. 010-330 Benton Harbor, Michigan 49022
Please send me my FREE Heathkit Catalog. I am not on your mailing list.	
Name _____	
Address _____	
City _____	State _____
CL-637	Zip _____

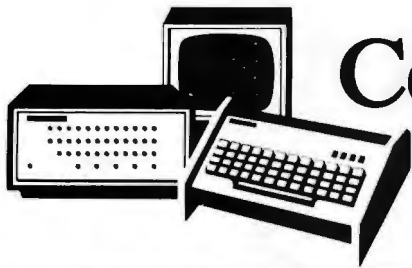

Computer Bits

By Hal Chamberlin

UPDATE ON MICROPROCESSOR DEVELOPMENTS

OVER THE past year, there has been a flood of new microprocessor IC's and related peripheral IC's coming on the market. Many have been rumored in the past but are now finally available. These new IC's are important to casual as well as advanced computer hobbyists because they will show up shortly in new hobbyist-oriented equipment offerings.

One obvious overall trend in microprocessor IC's has been toward true single-chip central processing units or even complete computers. With today's CPU chips, one merely adds memory, address decoding, and bus buffering to have a complete, expandable computer. The newest "computers on a chip" have the CPU, erasable read-only memory, read-write memory, and a couple of input-output ports all in one IC! Although these are not as easily expanded, they are ideal for use in terminals or intelligent game machines.

Another trend is toward I/O systems on a single chip. The TMS5501 IC from Texas Instruments, for example, combines a complete UART with baud-rate generator for serial I/O, a parallel input port, a parallel output port, 5 (count them) interval timers, and a vectored interrupt system into one IC! Another example is the MCS6530 from MOS Technology (now part of Commodore) and Synertek. This IC offers 1k bytes of read-only memory, 64 bytes of read-write memory, two *bidirectional* (programmable for input or output) parallel ports, and a very versatile interval timer. As a matter of fact, two of these are used in the KIM-1 to hold the monitor and provide its extensive I/O capabilities.

Complete peripheral controllers are also appearing in chip form. Most notable is the fact that no fewer than three different floppy-disk controller IC's are now available. Most of them are flexible enough to handle the disk formats in common use by hobbyists as well as the

"standard" and more complex IBM format for which the chips were designed. Another IC that has been announced but is not yet available is a video display chip with *programmable* line length and number of lines. Even the character read-only memory is built-in.

Memory developments certainly have not taken a vacation either. Static 4k memory chips have become cost effective alternatives to the common 1k 2102 chips and are now appearing in 16k-byte memory boards for the hobbyist. Earlier problems with dynamic memory chips have been overcome by correct board design and will be emerging as the price-performance leader in memory for the hobbyist since 4k dynamic memory chips are now selling for as little as \$2.70 in large quantities. Finally, the availability of 16k dynamic memory IC's makes possible the single-board "full gallon" (64k) memory system. In fact, IMSAI has announced a 64k memory board for its systems.

The 8080 Field. Even though the 8080 is the most popular microprocessor chip for hobbyist systems and has also enjoyed considerable success in

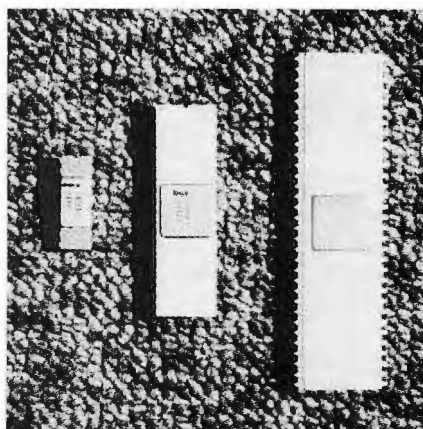

Size of microprocessors grows in proportion to sophistication of internal logic. Left to right, an 8008, 8080, and the latest 16-bit micro, a 9900 IC.

commercial systems, many significant improvements in the family have become available in the last year. Improved versions of the original 8080 that run at higher speeds are now available. The fastest is the 8080A-1 which can run at a clock speed of 3.125 MHz or over 60% faster than the standard 8080. Of course these higher speeds require faster memory to be of any benefit but many of the newer memory boards run fast enough.

To most people however, the most significant development is of course the Z-80. This microprocessor chip was introduced by Zilog, a spinoff company from Intel, the originators of the 8080. The Z-80 is fast; selected versions run at 4-MHz which is twice as fast as the 8080. Additionally, some instructions require fewer clock cycles to execute than the 8080 equivalents. The main attraction of the Z-80 for hobbyists however has been its extended instruction set. Besides all of the 8080 instructions, the Z-80 has many new ones. The most impressive class is the block search and move instructions. A single instruction, after the proper parameters have been loaded into registers, can perform a function that normally requires an entire subroutine. Besides the obvious savings in memory space, the block instructions execute much faster than the subroutine would. Other improvements are indexed addressing modes which simplify some types of programming and a duplicate set of registers which eliminates the need to save registers during interrupt.

One of the newest developments from Intel is designated the "MCS-85" family. Central to this family of chips is the 8085 microprocessor. This chip essentially combines the CPU, clock generator, and system bus controller functions onto one IC. In addition, 4 individually maskable vectored interrupts are included right on the CPU chip thus solving a bad problem with the original 8080. One of the most significant improvements is relaxed bus timing specifications. At equivalent throughput speeds, the 8085 allows memory access to stretch out as long as 1025 ns whereas the 8080 allows only 570 ns thus requiring a memory almost twice as fast. Even when the 8085 is sped up 50% to 3 MHz, the 575 ns allowed for memory access is longer than an 8080 at normal speed thus allowing a faster system without faster memory. Even with all of these improvements, the 8085 will execute all 8080 programs without changes.

Other 8-Bit Processors. Of course

the other microprocessor manufacturers have not twiddled their thumbs over the past year. Motorola has just announced faster versions of its popular 6800. The MC68A00 runs 50% faster at 1.5 MHz and the MC68B00 runs fully twice as fast at 2 MHz. Likewise, the 6502 microprocessor from MOS Technology is available in higher speed versions. The A suffix part is twice as fast at 2 MHz, the B suffix runs at 3 MHz, and the "dash C" part smokes at 4 MHz. Remember when comparing clock speeds that the above chips generally accomplish about as much in one clock cycle as an 8080-type chip does in three clock cycles.

National Semiconductor's SC/MP microprocessor has also been improved. It is now an n-channel MOS chip which means easier interfacing and a single 5-volt power supply. Additionally the speed has been doubled to 4 MHz (which is divided by 4 internally). Even with these improvements, its price remains the same.

The F-8 microprocessor originated by Fairchild normally requires at least two chips to make a complete CPU. However Mostek has recently announced a single chip F-8 that combines memory, an interval timer, and I/O ports all on the same chip.

16-Bit Microprocessors. To many people the ultimate hobby computer simply must have a full 16-bit minicomputer style instruction set. Accordingly, recent developments in 16-bit microprocessors are of great interest. A significant trend with the 16-biters has been to try to get it all on one chip even if it means a larger IC package as shown in the photo.

The PACE was the first single-chip 16-bit microprocessor to be introduced. Although National Semiconductor has not made any significant improvements in the chip itself, the price has improved considerably. From an initial figure of nearly \$200 (in 100 quantity), the price has recently fallen to only \$20.

Speaking of price reductions, the CP1600 processor by General Instruments has been recently repriced at \$8! The architecture is somewhat strange but the price is hard to beat and it is a 16-bit device.

Another 16-bit processor which has been rumored for awhile is now available. It is the 9900 from Texas Instruments. This IC is unique in many respects. Most striking is the 64-pin package which looks more like a small printed circuit board with leads than a ceram-

ic IC. The instruction set in many ways resembles that of a DEC PDP-11, a very popular minicomputer. An interesting design innovation is that the "registers" are not in the CPU but are in regular read-write memory. Another feature is the inclusion of real multiply and divide instructions which take only about 20 microseconds to execute. The standard 9900 requires a 16-bit wide memory but a "soon-to-be-introduced" version (the 9980) can work with an 8-bit data bus and memory while retaining the same extensive 16-bit instruction set. This means that CPU boards using the 9980 might be compatible with the S-100 bus structure. The 9980 will also be packaged in a more conventional 40-lead package.

Bipolar Bit Slices. While not really microprocessor chips, the bipolar bit slices are building blocks that can be used to design custom computers and instruction sets with much less effort and far fewer parts than would be required with standard logic. Since they are made with high-speed Schottky transistors rather than MOS transistors, the speed of a system constructed with bipolar slices is much greater. Major innovations in this area are sharply lower prices and the availability of 4-bit wide units along with a host of support chips. Of significance to the hobbyist is the fact that a couple of hobbyist manufacturers are readying CPU boards made with the bit slices. These will be compatible with the S-100 bus and immediately provide the user with a vastly superior CPU while still using the rest of the existing system. Since the bit slices are *microprogrammed*, it is possible that a standard feature would be an *emulation mode* in which the instruction set of a popular microprocessor such as the 8080 would be recognized as well as the improved instruction set offered with the new CPU.

Bipolar bit slices will probably also show up in specialized floating-point arithmetic units. The purpose of these is to execute the arithmetic operations needed by BASIC language systems much faster than typical software routines do.

If the past is any indication, new microprocessor developments will continue to be made at an ever accelerating pace.

Correction. In last month's column, the price of the Heathkit H9 CRT terminal was given as \$350. It should have been \$530. ◇

Autoranging Frequency Counting to 60 MHz with 1Hz Resolution



B&K-PRECISION MODEL 1801 \$240

- For laboratory, production line or maintenance applications
- Automatic ranging, 20 Hz to 40 MHz is guaranteed...readout to 60 MHz is typical
- TTL circuitry updates the six-digit display five times per second
- Resolution to 1 Hz obtained by suppressing digits above 1 MHz when switching to 1 SEC mode



MHz display of
3.579548 MHz input (AUTO mode)



KHz display of overflow of
3.579548 MHz input (1SEC mode)

- Available for immediate delivery, from local B&K-PRECISION distributors
- 10-day free trial offer

B&K PRECISION
PRODUCTS OF DYNASCAN

6460 West Cortland Avenue
Chicago, Illinois 60635 • 312/889-9087
In Canada: Atlas Electronics, Toronto

Put Professional Knowledge and a
COLLEGE DEGREE
in your Electronics Career through

HOME STUDY

Earn Your DEGREE

by correspondence, while continuing your present job. No commuting to class. Study at your own pace. Learn from complete and explicit lesson materials, with additional assistance from our home-study instructors. Advance as fast as you wish, but take all the time you need to master each topic. Profit from, and enjoy, the advantages of directed but self-paced home study.

The Grantham electronics degree program begins with basics, leads first to the A.S.E.T. degree, and then to the B.S.E.E. degree. Our free bulletin gives complete details of the program itself, the degrees awarded, the requirements for each degree, and how to enroll. Write for *Bulletin E-77*.

Grantham College of Engineering
2000 Stoner Avenue
P. O. Box 25992
Los Angeles, CA 90025

Worldwide Career Training thru Home Study
CIRCLE NO. 29 ON FREE INFORMATION CARD

KIT TOOL

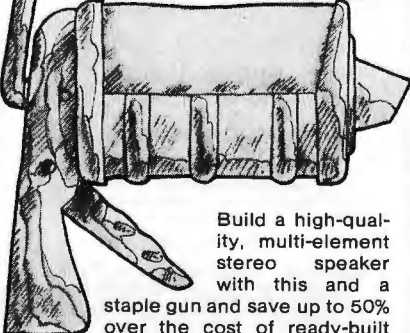

Build a high-quality, multi-element stereo speaker with this and a staple gun and save up to 50% over the cost of ready-built speakers. No cabinetry. No soldering. Just affordable quality with a few hours work. Send for our free 48-page catalog-manual if you think you could handle it.

I can handle it. PE-E
Send me my free 48-page catalog-manual.

NAME _____

ADDRESS _____

CITY _____

STATE _____

ZIP _____

Speakerlab®
Dept. PE-E, 5500 35th NE, Seattle, WA 98105

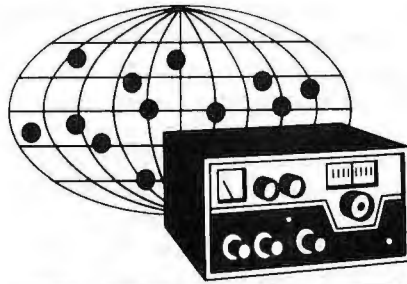

DX Listening

By Glenn Hauser

PUBLICATIONS

AN AMAZING amount of excellent printed material relating to international radio is available, once you know how to get it. Most of it you would never find, no matter how long you looked, even in the largest libraries. It's produced by enthusiastic individuals, with expertise in their specialties, even though they are nonprofessionals. Here's a selection of such publications, and how to get them.

Review of International Broadcasting is a monthly magazine in which listeners exchange views on programming. It fills the vacuum left by most DX clubs, which emphasize picking up stations, rather than listening to their programming—which, after all, is the reason stations broadcast. Sample, 50¢ or 12 issues for \$6.00 from Glenn Hauser, WUOT, University of Tennessee, 245 C&E Bldg., Knoxville, TN 37916.

Down Under DX Survey, a quarterly, mimeographed bulletin, concentrates on Asian stations, with extensive band surveys, special reports, etc. Only active contributors may join the group, but anyone may order individual issues, for 6 IRC's (International Reply Coupons) from Down Under DX Circle, 7 Donald Road, Burwood, Victoria, Australia 3125.

Far Eastern DX Review is a similar bulletin compiled by four Japanese experts (in English), but is monthly and Xeroxed. Samples are 8 IRC's or \$2. A year by air is \$20, or by surface mail, \$15, from Japanese Association of DXers, Box 1766 Tokyo Central, Tokyo 100-91, Japan.

Russian Reporting Guide is a separate JADX publication, available for 4 IRC's from the address above. Claims to be "the most detailed guide for reporting in Russian and for understanding domestic services in the USSR."

USSR High-Frequency Broadcast Newsletter provides otherwise hard-to-get schedules of Soviet transmissions based on monitoring: including educated guesses on the transmitter sites actually used, contradicting official informa-

tion from the USSR itself. Sample for SASE, or 12 issues of the approximately monthly publication for only \$3, from Roger Legge, Box 232, McLean, VA 22101.

World Broadcasting Information is a weekly compilation of schedules, and monitored developments in broadcasting, by and for professionals, but available to individual subscribers. Costs vary around \$60 per year, but a free sample is offered from: Organiser, News & Publications, BBC Monitoring Service, Caversham Park, Reading, England.

DX Information Service Catalog is free from Radio Nederland, Box 222, Hilversum, Holland. Lists free technical courses, antenna booklets, etc.

Mail-a-Prop is a two-page fortnightly summary of propagation condition predictions, compiled by George Jacobs, primarily for amateurs, but also can be applied by listeners to other bands. Sample and rates from Mail-a-Prop, Box 86, Northport, NY 11768.

SPEEDX Utility Guide attempts to do for nonbroadcast listening what the World Radio-TV Handbook does for broadcasting. This year's edition is \$6.95 from SPEEDX, Box E, Elsinore, CA 92330.

Listen to the World on Shortwave—Ask Me! Red and white vinyl bumper stickers are also available from SPEEDX, at 50¢ each.

Handler Enterprises, P.O. Drawer CC, Northfield, IL 60093, offers a free catalog of its reasonably priced station lists, primarily of military and government utility stations, difficult to obtain elsewhere.

GILFER Associates provides a number of books about aspects of DX listening, and a line of equipment. Ask for catalog. GILFER, Box 239, Park Ridge, NJ 07656.

National Radio Club provides extensive reprints of technical and nontechnical articles dealing with mediumwave reception and gear; for a list, send an SASE to NRC Publications Center, Box 401, Gales Ferry, CT 06335.

Worldwide TV-FM DX Association

does the same with articles on vhf/uhf reception and equipment. Ask for a catalog from WTFDA Reprint Service, Box 202, Whiting, IN 46394.

ANARC Directory of DX Club Publications extends even further the list given here. Send a #10 SASE with 24¢ postage to Association of North American Radio Clubs, 557 N. Madison Ave., Pasadena, CA 91101.

EDXC List of 600 DX Publications of the World is available for 5 IRC's from European DX Council, Box 250325, D-4630 Bochum, German Federal Republic.

International Broadcast Institute publishes case studies of broadcasting in different countries, intended for scholars, but may be of interest to the serious DX listener. Ask for a list of publications available, from IBI, Tavistock House East, Tavistock Square, London, WC1H 9LG, England.

Comings & Goings. South Africa's Radio Five, the successor to Mozambique's "LM Radio", planned to come up in August via two new 100-kW short-wave transmitters, probably using 31 or 41m in the daytimes, and 75m at night. Meanwhile, the international service, Radio RSA is overhauling its four 250-kW transmitters and replacing them with three 500-kW senders.

Radio Voice of the Gospel, a Lutheran station in Ethiopia, was nationalized in March, and renamed Radio Voice of Revolutionary Ethiopia. The latest schedule we have shows the only frequencies in use to be 6015 and 7180 kHz, opening at 1300 GMT in Somali, when they should be audible in western North America via long path, but not during the English program at 1630.

Both Vatican Radio in Italy for the Catholics, and HCJB in Ecuador for the Evangelical Protestants, are installing 500-kW transmitters and gigantic rotatable antennas to improve their outreach.

Australia is planning a new domestic shortwave service for its Northern Territory, transmitted both from Darwin, and from Adelaide, South Australia. Also, \$63 million (Australian) has been appropriated to modernize Radio Australia overseas transmitters in Victoria, and further expansion on the west coast is also being considered including between Australia and overseas.

Radio Nacional Brasilia abruptly suspended its international service in mid-June, citing technical reasons. The reasons were really political, however. The Brazilian government couldn't wait until next year when RNB is slated to get five POPULAR ELECTRONICS

The All-American Wide Receiver

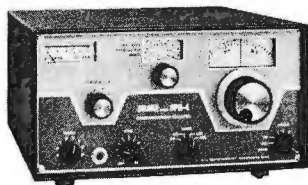

DRAKE SPR-4 Short Wave Receiver

- Direct Frequency Dialing • All Solid State
- Programmable Coverage • FET Circuitry

A general purpose receiver, the SPR-4 may be programmed to suit any interest: SWL, Amateur, Laboratory, Broadcast, Marine Radio, etc. Freq. Coverage: 150-500 KHz plus any (23) 500 KHz ranges, 500 to 30 MHz.

FEATURES: • Linear dial with 1 KHz read-out • 4-pole crystal filter in first IF • 4-pole LC filter in second IF • Three bandwidths: 0.4 KHz, 2.4 KHz, and 4.8 KHz for: CW, SSB, AM • Superior cross-modulation and overload performance • Power: 120 VAC, 220 VAC, or 12 VDC • Crystals supplied for LW, BC and seven SW bands • Built-in speaker • Notch Filter.

ACCESSORIES: 100 KHz calibrator, noise blanker, DC power cord, loop antenna, crystals for other ranges.

For complete details contact:



R. L. DRAKE COMPANY

540 Richard St., Miamisburg, Ohio 45342, Phone: (513) 866-2421 • Telex: 288-017

CIRCLE NO. 18 ON FREE INFORMATION CARD

Try this exciting new hobby!

Build your own electronic concert organ. It's easy. No technical knowledge required. Just follow the clearly pictured instructions of the famous Wersi do-it-yourself system. Choose from seven different models. Send \$2.00 (refundable) with coupon for colorful 104 page catalog.



Wersi Electronics, Inc.
Dept. 42, Box 5318
1720 Hempstead Road
Lancaster, PA 17601

Enclosed is \$2.00 for my copy of your 104 page catalog.

Name _____
Address _____
City _____ State _____ Zip _____

CIRCLE NO. 62 ON FREE INFORMATION CARD

BUILD YOUR OWN

BIG SCREEN COLOR TV!

YOU ASKED FOR IT!

- Sporting Events Are An Experience As Exciting As Being There!
- Movies Are Seen The Way They Were Meant To Be Seen!
- Ping And Other Video Games Are More Exciting Than Ever!
- Can Be Used With Video Tape Playback Equipment!

THE NEW LIFESCREEN II



The SELF-CONTAINED internal projection TV that will utilize any transistor portable TV (12" to 19")... requires only 2 x 4 feet of floor space - fits neatly against any wall... and lends its beauty to the decor of any room.

COMPONENT LIST

- 1 set of LIFESCREEN II Plans
- 1 Portable transistor Color TV (12" to 19")
- 1 LIFESCREEN Lens
- 2 LIFESCREEN Front Surface Mirrors: one 8"x10" and one 14 1/2"x20"
- 1 EXTRON LS 50 Screen, 32"x40"/50" Diag.

WE HAVE RECEIVED THOUSANDS OF INQUIRIES!

YOU REQUESTED PLANS FOR A BIG SCREEN TV THAT WOULD: utilize any portable TV as an image source - require a minimum of floor space - be a beautiful piece of furniture.

NOW - EXTRON IS HAPPY TO ANNOUNCE

THE NEW LIFESCREEN II

The LIFESCREEN was designed for the Do-It-Yourself enthusiast who wishes to have the enjoyment and excitement of a professional Big Screen TV - but refuses to pay the \$1500 to \$4000 that most manufacturers charge for this luxury.

FACTS

The special LIFESCREEN, Lens and Front Surface mirror supplied by Extron are the same type used by major Big Screen TV manufacturers (Sony, Muntz, etc.). THESE PROFESSIONAL COMPONENTS SHOULD NOT BE CONFUSED WITH THE CHEAP PLASTIC MAGNIFYING IMITATIONS NOW FLOODING THE MARKET BECAUSE OF THE POPULARITY OF BIG SCREEN TV.

The EXTRON TV Screen - the same used by the major Big Screen TV manufacturers - is 16 TIMES BRIGHTER than a flat matte surface and 6 TIMES BRIGHTER than most flat beaded movie screens. Its parabolic shape rejects extraneous light, concentrating a highly efficient and directionally selective television image that is exceptionally sharp and colorful.

COMPLETE LIFESCREEN II PACKAGE: \$299

YOU SUPPLY PARTICLEBOARD & FORMICA FINISH TAKES 10 TO 15 HOURS TO BUILD. NO SPECIAL TOOLS OR ELECTRONIC SKILLS REQUIRED. TV not included.

COMPLETE LIFESCREEN I PACKAGE: \$269

THE EVERYTHING GUARANTEE

EXTRON GUARANTEES EVERYTHING: THE PROFESSIONAL QUALITY, ACCURACY OF DESCRIPTION, AVAILABILITY AND PROMPT DELIVERY OF COMPONENTS DESCRIBED IN THIS AD. If, after building your LIFESCREEN PROJECTION SYSTEM, you are not satisfied for any reason, return all components to EXTRON, 8831 Sunset Boulevard, West Hollywood, California for instant refund of the purchase price.

THE ORIGINAL LIFESCREEN I



The INDEPENDENT projection system that can be used with ANY SIZE screen up to 80" Diagonal - one of the many reasons for its tremendous success.

- COMPONENT LIST
- 1 set of LIFESCREEN I Plans
 - 1 Sharp 13" Model 13A21 Color TV or Sony 15" Model KV 1541R Color TV
 - 1 LIFESCREEN Lens
 - 1 EXTRON LS 50 Screen 32"x40"/50" Diagonal

LARGER SCREENS can be ordered through EXTRON (67" or 80" Diag.)

- PLEASE RUSH ME ONE COMPLETE SET OF LIFESCREEN I PLANS @ \$9.00
- PLEASE RUSH ME ONE COMPLETE SET OF LIFESCREEN II PLANS @ \$9.00

PLEASE ALSO SEND ME THE ITEMS CHECKED BELOW:

- LIFESCREEN LENS @ \$150.00
- LIFESCREEN FRONT SURFACE MIRROR, 8" x 10" @ \$20.00
- LIFESCREEN FRONT SURFACE MIRROR, 14 1/2" x 20" @ \$30.00
- EXTRON LS 50 SCREEN 32" x 40"/50" Diagonal @ \$90.00
- COMPLETE LIFESCREEN I PACKAGE @ \$269.00
- COMPLETE LIFESCREEN II PACKAGE @ \$299.00

All Prices F.O.B. factory - Cal. residents add 6% sales tax.

TOTAL: \$ _____

EXTRON LIFESCREEN® PROJECTION SYSTEM
8831 Sunset Boulevard,
West Hollywood, California 90069

Name _____
Address _____
City _____ State _____ Zip _____
CARD NAME _____
CARD NUMBER _____ EXPR. DATE _____

INFO PAK - 50¢

CIRCLE NO. 26 ON FREE INFORMATION CARD



NEW EICO 700 FREQUENCY COUNTER KIT \$69.95

At last! A digital counter every CB'er/Hobbyist can afford. Exclusive transmitter-Keyed "sniffer" circuit activates counter only on transmit, giving accurate readout of channel frequency. Standard coax connectors and mounting brackets make mobile installation a snap. IC Digital circuitry. Freq. range: 5 Hz-27 MHz (all 40 CB channels) Accuracy: ± 1 PPM ± 1 Digit. Readout: Five 0.5" LED Displays; 10 MHz crystal oscillator KHz/MHz Timebase switch; Compact design: 2 $\frac{3}{8}$ "H x 6 $\frac{1}{8}$ "W x 5 $\frac{3}{8}$ "D. **Assembled \$99.95**

FREE '78 EICO CATALOG

Check reader service card or send 75¢ for first class mail. See your local EICO Dealer or call (212) 272-1134, 9:00 a.m.-5:00 p.m. EST. Major credit cards accepted.

EICO-283 Malta St.,
Brooklyn, N.Y. 11207



CIRCLE NO. 20 ON FREE INFORMATION CARD

SAVE!

MONEY • TIME • FREIGHT

QUALITY STEREO EQUIPMENT
AT LOWEST PRICES.

YOUR REQUEST FOR QUOTA-
TION RETURNED SAME DAY.

FACTORY SEALED CARTONS—
GUARANTEED AND INSURED.

SAVE ON NAME BRANDS LIKE:

A.D.C. KLH

A.R. SHURE

DYNACO KOSS

SONY FISHER

PIONEER

AND MORE THAN 50 OTHERS
BUY THE MODERN WAY
BY MAIL—FROM

illinois audio

Department 217S
12 East Delaware
Chicago, Illinois 60611
312-664-0020

CIRCLE NO. 32 ON FREE INFORMATION CARD

new transmitters. It decided instead to take RNB off the air so its one transmitter could be used for domestic broadcasts into Amazonia—where foreign broadcasts have been dominating the airwaves. No date of return was given, and there was a note of sadness in announcer John Morris's voice. We'll certainly miss this friendly, soft-line station.

But another friendly Latin American station made a comeback in June—Radio Clarin, from the Dominican Republic. They've had power supply problems for their 50-kW transmitter on 11700 kHz. Rudy Espinal, host of the English program at 2330 GMT, on his

first day back on the air, intimated that the time would be changed, or there would be an additional broadcast at a more convenient hour for Europe.

BBC's Far Eastern Station is moving from Malaysia across the Straits to Singapore. As the move is in phases, for a time BBC will be broadcasting from both countries, and not telling us which frequency is from which.

WYFR is also moving, from Massachusetts to Florida, near Lake Okeechobee, where there's more room for expansion; they too will be broadcasting from both locations until the move is complete. ◇

ENGLISH-LANGUAGE SHORTWAVE BROADCASTS FOR SEPT. & OCT.

by Richard E. Wood

TO EASTERN NORTH AMERICA

TIME EDT	TIME GMT	STATION	QUAL *	FREQUENCIES MHz
6:28 a.m.-8:00 p.m.	1028-2400	**Montreal, Canada (Northern Service)	G	9.625, 11.72 (includes French, etc.)
7:00-7:25 a.m.	1100-1125	Tirana, Albania	F	9.50, 11.985
7:00-9:00 a.m.	1100-1300	Melbourne, Australia	G	9.58
		London, England	G	5.99 (via Sackville), 6.195 (via Antigua)
7:00-10:00 a.m.	1100-1400	**VOA, Washington, USA	G	5.955, 9.73
8:00-8:30 a.m.	1200-1230	Jerusalem, Israel	G	11.856, 15.23, 15.415, 17.795, 17.815
8:00-8:55 a.m.	1200-1255	Peking, China	F	11.695
8:10-8:30 a.m.	1210-1230	**Santiago, Chile	G	9.566, 11.81, 15.15
8:15-8:30 a.m.	1215-1230	Athens, Greece	P	15.345, 17.83
		HCB, Quito, Ecuador	G	11.745
8:30-9:00 a.m.	1230-1300	Stockholm, Sweden	G	15.305
8:30-9:20 a.m.	1230-1320	Trans-World Radio, Bonaire, N.A.	G	15.255 (Sat., to 1420 Sun.)
8:30-11:30 a.m.	1230-1630	HCB, Quito, Ecuador	G	11.745, 15.115
9:00-9:25 a.m.	1300-1325	Helsinki, Finland	G	15.105
9:00-9:30 a.m.	1300-1330	London, England	G	5.99 (via Sackville), 6.195 (via Antigua), 11.775 (via Antigua, Sat., Sun: from 1200)
9:15-9:45 a.m.	1315-1345	Berne, Switzerland	G	15.14
10:00-10:15 a.m.	1400-1415	**Montreal, Canada	G	15.29, 17.78
10:00-10:30 a.m.	1400-1430	Stockholm, Sweden	G	15.305
11:00 a.m.-12 noon	1500-1600	London, England	G	17.84 (via Ascension), 9.58 (via Sackville Sat., Sun.)
11:15-11:30 a.m.	1515-1530	Athens, Greece	F	11.73, 15.345, 17.83
12 noon-12:15 p.m.	1600-1615	London, England	G	9.58 (via Sackville), 17.84 (via Ascension)
12 noon-12:30 p.m.	1600-1630	Oslo, Norway	F	15.175 (Sun.)
12:04-12:56 p.m.	1604-1656	**Paris, France	G	11.705, 11.89, 11.93, 11.965, 15.20, 15.30, 15.425, 17.72, 17.795 (from Sept. 24-1704-1756)
12:15-1:09 p.m.	1615-1709	London, England	G	9.58 (via Sackville, Sat., Sun. 1745)
12:42-12:50 p.m.	1642-1650	Hilversum, Holland	G	15.19, 17.775, (alt. 17.825, Mon-Fri, via Bonaire)
12:45-1:00 p.m.	1645-1700	**Montreal, Canada	G	15.325, 17.82
1:00-4:00 p.m.	1700-2000	**Kuwait, Kuwait	G	9.555, 12.085 (varies)
2:00-2:30 p.m.	1800-1830	**Montreal, Canada	G	15.25, 17.82
		**Kampala, Uganda	F	15.325 (Tues., Thur., Sat., Sun.)
2:50-4:00 p.m.	1850-2000	**Abidjan, Ivory Coast	G	11.92 (Sun.)
3:00-3:30 p.m.	1900-1930	**Montreal, Canada	G	15.25, 17.82
		**Tehran, Iran	F	9.022 (from Oct. 2000-2030)
3:00-6:00 p.m.	1900-2200	**Jeddah, Saudi Arabia	F	11.855
3:30-4:00 p.m.	1930-2000	**Montreal, Canada	G	11.855, 15.325, 17.735
		**Baghdad, Iraq	F	9.745
4:00-4:30 p.m.	2000-2030	Jerusalem, Israel	G	7.4125, 9.63, 9.815
4:00-5:00 p.m.	2000-2100	Accra, Ghana	F	11.85 (irregular)
4:00-5:20 p.m.	2000-2120	**Hilversum, Holland	G	11.73 (via Talata)
4:30-5:00 p.m.	2030-2100	**Montreal, Canada	G	11.855, 15.325, 17.82
4:50-5:50 p.m.	2050-2150	**Havana, Cuba	G	11.865, 17.75
5:00-5:50 p.m.	2100-2150	**Johannesburg, S. Africa	F	5.98, 7.27, 9.585
5:15-6:00 p.m.	2115-2200	London, England	G	9.58, 11.78

5:30-6:00 p.m.	2130-2250	Hilversum, Holland	G	9,715, 11,73 (exc. Sun.)
5:00-6:15 p.m.	2200-2215	**Belgrade, Yugoslavia	F	6,10, 7,24, 9,62
5:00-6:30 p.m.	2200-2230	Oslo, Norway	F	11,85, 15,175 (Sun.)
5:00-6:45 p.m.	2200-2245	London, England	G	6,175, 9,51 (both via Sackville), 9,58, 11,78
6:00-7:15 p.m.	2200-2315	**Cairo, Egypt	G	9,805
6:00-8:00 p.m.	2200-2400	Montreal, Canada	G	5,96 (Mon.-Fri.)
6:00-8:30 p.m.	2200-0030	Ankara, Turkey	G	9,515, 11,88
6:30-7:00 p.m.	2230-2300	Jerusalem, Israel	G	7,4125, 9,435, 9,63, 9,815, 11,655
		Moscow, U.S.S.R.	G	5,94, 6,125, 7,10, 7,115, 7,205, 7,355, 7,44
6:30-7:20 p.m.	2230-2320	Johannesburg, S. Africa	G	5,98, 9,585, 11,90
6:30-8:30 p.m.	2230-0030	Ankara, Turkey	G	9,515, 11,88
6:45-7:30 p.m.	2245-2330	London, England	G	5,975, 6,175, (via Sackville), 7,325, 9,58
6:50-7:10 p.m.	2250-2310	**Santiago, Chile	F	9,566, 11,81, 15,15
7:00-7:30 p.m.	2300-2330	Stockholm, Sweden	G	6,045, 6,12, 9,695
		London, England	G	5,975, 6,175 (via Sackville), 7,325, 9,58 (via Ascension)
		Vilnius, U.S.S.R.	G	7,15, 7,215, 7,245, 7,29
			G	7,32, 7,40
7:00-7:50 p.m.	2300-2350	**Buenos Aires, Argentina	G	11,71 (Mon.-Fri.)
7:00-9:30 p.m.	2300-0130	Moscow, U.S.S.R.	G	5,94, 6,125, 7,10, 7,115 (via Bulgaria), 7,205, 7,355, 7,44
7:30-7:55 p.m.	2330-2355	Helsinki, Finland	P	11,755
7:30-11:30	2330-0330	London, England	G	5,975, 6,12 (via Sackville), 6,175 (via Antigua), 7,325, 9,51 (via Sackville; from 0030, Greenville), 9,58 (from 0030, via Ascension)
7:45-8:45 p.m.	2345-0045	Tokyo, Japan	F	11,705, 15,30
8:00-8:25 p.m.	0000-0025	Tirana, Albania	G	7,065, 9,75
8:00-8:30 p.m.	0000-0030	Oslo, Norway	F	6,18, 9,645 (Sun.)
8:00-8:55 p.m.	0000-0055	Sofia, Bulgaria	G	9,70 (alternate 9,705, 7,115)
		Peking, China	G	11,675, 11,945, 15,06
8:00-9:00 p.m.	0000-0100	**VDA, Washington, USA	G	6,19, 9,67, 11,83, 11,895
8:00-10:45 p.m.	0000-0245	**Luxembourg	F	6,09
8:00 p.m.-1:06 a.m.	0000-0506	**Montreal, Canada (Northern Service)	F	6,195, 9,625 (includes Eskimo, etc.)
8:15-8:30 p.m.	0015-0030	Athens, Greece	F	9,76, 11,73
8:15-8:45 p.m.	0015-0045	Brussels, Belgium	F	9,225 (varies)
8:40 p.m.-1:00 a.m.	0040-0700	HCJB, Quito, Ecuador	G	6,095, 9,56, 11,915
9:00-9:15 p.m.	0100-0115	Vatican, City	G	5,995, 6,015, 9,605, 11,70
9:00-9:20 p.m.	0100-0120	Rome, Italy	F	6,01, 9,575
9:00-9:30 p.m.	0100-0130	Montreal, Canada	G	9,535
9:00-9:45 p.m.	0100-0145	Berlin, Ger. Dem. Rep.	P	9,73
9:00-9:55 p.m.	0100-0155	Prague, Czechoslovakia	G	5,93, 7,345, 9,54, 9,63, 9,74
9:00-11:00 p.m.	0100-0300	Melbourne, Australia	F	15,32, 17,795
9:00-11:30 p.m.	0100-0330	Havana, Cuba	G	9,685, 11,725
9:00 p.m.-12 mdt.	0100-0400	Madrid, Spain	G	6,065, 11,88 (exc. Sun.)
9:10-9:30 p.m.	0110-0130	**Santiago, Chile	F	9,566, 11,81, 15,15
9:30-9:50 p.m.	0130-0150	Cologne, Ger. Fed. Rep.	G	6,01, 6,04 (via Antigua), 6,075, 6,10 (via Malta), 9,585, 9,605, 11,685 (via Malta)
			G	6,20, 7,30
9:30-9:55 p.m.	0130-0155	Tirana, Albania	G	6,155, 9,77
9:30-10:25 p.m.	0130-0225	Vienna, Austria	P	5,99, 6,18, 9,67, 9,69, 11,775, 11,94
9:30-11:00 p.m.	0130-0300	Bucharest, Rumania	G	5,94, 6,07 (via Sofia), 6,125, 7,105, 7,115 (via Bulgaria), 7,205, 7,355, 7,44
		Moscow, U.S.S.R.	G	5,965, 6,135, 9,725, 11,715
9:45-10:15 p.m.	0145-0215	Berne, Switzerland	F	6,00, 7,215, 9,585, 11,91 (Exc. Sun.)
10:00-10:30 p.m.	0200-0230	Budapest, Hungary	F	6,18, 9,645 (Sun.)
		Oslo, Norway	P	9,605, 9,655
		Montreal, Canada	G	6,095, 6,135, 7,27, 9,675, 11,815, 11,84, 15,12
		Warsaw, Poland	P	11,815, 15,12
10:00-10:55 p.m.	0200-0255	Peking, China	F	9,94, 12,015, 12,055, 15,06
10:00-11:20 p.m.	0200-0320	Hilversum, Holland	G	6,165 (via Bonaire)t
10:00-11:30 p.m.	0200-0330	Cairo, Egypt	G	7,12, 9,475
10:10-10:30 p.m.	0210-0230	**Santiago, Chile	F	9,566, 11,81, 15,15
10:15-10:30 p.m.	0215-0230	Athens, Greece	F	9,76, 11,73
10:30-10:55 p.m.	0230-0255	Tirana, Albania	G	6,20, 7,30
10:30-11:00 p.m.	0230-0300	Stockholm, Sweden	F	6,115, 9,695
10:30-11:15 p.m.	0230-0315	Berlin, Ger. Dem. Rep.	P	9,73
11:00-11:30 p.m.	0300-0330	Budapest, Hungary	F	6,00, 7,215, 9,585, 11,91 (Tue., Fri.)
		Kiev, U.S.S.R.	G	5,98, 7,215, 7,245, 7,39, 7,40, 9,78
		Lisbon, Portugal	F	6,025, 11,935
		Warsaw, Poland	P	6,095, 6,135, 7,27, 9,675, 11,815, 15,12
11:00-11:35 p.m.	0300-0335	Warsaw, Poland	P	6,095, 6,135, 7,27, 9,675, 11,815, 15,12
11:00-11:55 p.m.	0300-0355	Peking, China	G	7,12, 9,78 (both via Tirana)
		Buenos Aires, Argentina	G	9,69 (Mon., Fri.)
		Prague, Czechoslovakia	G	5,93, 7,345, 9,54, 9,63, 9,74
11:00 p.m.-12 mdt.	0300-0400	Moscow, U.S.S.R.	G	5,94, 6,07 (via Sofia), 6,125, 7,115 (via Bulgaria), 7,205, 7,355, 7,44
11:10-11:30 p.m.	0310-0330	**Santiago, Chile	F	9,566, 11,81, 15,15



Includes Functional Tilt Stand!

NEW EICO 270 3½ DIGIT DMM KIT ONLY \$79⁹⁵.

Introductory Offer—FREE AC ADAPTOR

The first and only lab accuracy portable DMM Kit featuring MOS/LSI IC economy and reliability. Measures DC/AC Volts, Kilohms, DC/AC milliamps in 21 ranges. Polarity indicators and overload protection are provided, and 0.5 inch LED displays give easiest-to-read digital readout to 1999. The 270 features a basic 0.5% DC accuracy, 10 Meg-ohm input impedance, low voltage drop in all current ranges and automatically-flashing overrange indicator. **Assembled \$109.95**

FREE '78 EICO CATALOG
Check reader service card or send 75¢ for first class mail. See your local EICO Dealer or call (212) 272-1134, 9:00 a.m.-5:00 p.m. EST. Major credit cards accepted.

EICO—283 Malta St., Brooklyn, N.Y. 11207



CIRCLE NO. 20 ON FREE INFORMATION CARD

FREE catalog

of over **2000** small tools, measuring instruments, and supplies



National Camera, Inc.
25th Anniversary 1952-1977

- ELT. COL. DRILLS
- FILM LOADERS...
- PS. PAGES... GRAVERS
- GRINDERS... HAMMERS...
- INCLINOMETERS... JACKS...
- KNIVES... LATHES... LEATHER...
- ETTES... LOUPES... MINIATURE TOOLS... METRIC TOOLS... MULTI-TESTERS... NEGATIVE FILES...
- NIPPERS... OILERS... PIN VISES...
- PLIERS... PROBES... RIFFLERS...
- SCISSORS... SNARES... SOLDERING SUPPLIES... TEST INSTRUMENTS... TWEEZERS... VIEWERS... VISES... WRENCHES...
- ADH. ABRASIVES... G... BOOKS
- LIMATORS... EPOXIES... CALIPERS...

National Camera
2000 West Union Ave. Dept. 100
Englewood, Colo., U.S.A. 80110

CIRCLE NO. 40 ON FREE INFORMATION CARD

THE PAIA 8700 COMPUTER/CONTROLLER

An exceptional price on an applications oriented 6503 based micro-processor system

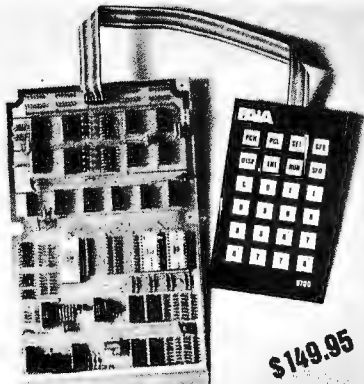

\$149.95

THE IDEAL, LOW COST SOLUTION TO IMPLEMENTING THOSE WILD COMPUTER BASED CONTROL SYSTEMS YOU'VE BEEN DREAMING OF!

PAIA software currently available or under development includes: Music synthesizer interface; Home applications package including: multi-zone fire/burglar alarm, real time clock, energy saving heat/air conditioning control, computer generated 'door-bell'; Model railroad controller and more.....

8700 COMPUTER/CONTROLLER KIT \$149.95
(requires 5v. @ 1. 2A. ; 12v. @ 150 ma.)

Shipped direct from PAIA (add \$3. 00 postage)
Also available at FULL LINE COMPUTER stores

DETAILS IN OUR FREE CATALOG

PAIA • DEPT. 9-P • 1020 W. Wilshire Blvd. •
Oklahoma City, OK 73118
0056 CIRCLE NO. 46 ON FREE INFORMATION CARD

Now! Write and run machine language programs at home plus design circuits using a microprocessor!

microprocessor/ minicomputer

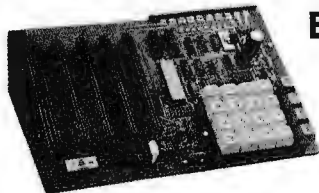

ELF II

\$99.95

SEND TODAY

NETRONICS R&D LTD., Dept. PE97
Phone (203) 354-9375
333 Litchfield Road, New Milford, CT 06776

Yes! I want to run programs at home and have enclosed: \$99.95 plus \$3 p&h for ELF II kit. Featured in POPULAR ELECTRONICS. Including all components plus everything needed to write and run machine language programs plus the new Pixie chip that lets you display video graphics on your TV screen. Designed for engineers, students and hobbyists who need training in computer programming and micro-processor circuit design. Features RCA 1802 COSMAC COS/MOS 8-bit microprocessor addressable to 64k bytes, 256 byte RAM, full hex keyboard, two hex-digit output display, crystal clock for timing applications and double-sided plated-through pc circuit board. Requires 6.3 VAC transformer. Optional 5 card expansion bus (less connectors) for memory expansion, cassette I/O, A to D and D to A converters, PROM and a host of other I/O's. Manual includes instructions for assembly, testing, programming, video graphics and games plus how to receive ELF Users' Club bulletins.

\$149.95 plus \$3 for ELF II wired & tested. (Includes 6.3 VAC power supply and RCA 1802 User's Manual.)

\$5.00 for RCA 1802 User's Manual. Connecticut residents please add sales tax.

NAME _____

ADDRESS _____

CITY _____ STATE _____ ZIP _____

Send me information on your other kits!

11:30-11:55 p.m.	0330-0356	Tisana, Albania	G	6.20, 7.30
		Vienna, Austria	P	6.155, 9.77
11:30 p.m.-12:30 a.m.	0330-0430	London, England	G	5.975, 6.175 (via Antigua)
11:30 p.m.-12:50 a.m.	0330-0450	Havana, Cuba	G	6.585, 11.725, 11.76
12:00 mid.-12:15 p.m.	0400-0415	Budapest, Hungary	F	6.00, 7.215, 9.595, 11.91 (Thurs. Fri.)
12:00 mid.-12:25 a.m.	0400-0425	Bucharest, Rumania	F	5.99, 6.155, 6.19, 9.57, 9.69, 11.775, 11.94
12:00 mid.-12:30 a.m.	0400-0430	Oslo, Norway	F	6.18, 9.645 (Sun.)
12:30-1:00 a.m.	0430-0500	London, England	G	6.175 (via Antigua)
		Tisana, Albania	G	7.30, 9.48
12:50-2:00 a.m.	0450-0600	Havana, Cuba	G	11.725, 11.76
1:00-1:15 a.m.	0500-0515	Jerusalem, Israel	G	5.90, 7.425, 9.63, 9.82, 11.86, 12.045
1:00-1:30 a.m.	0500-0530	Lisbon, Portugal	F	6.025, 11.935
1:00-2:30 a.m.	0500-0630	London, England	G	6.175, 9.51 (both via Antigua)
2:30-3:30 a.m.	0630-0730	London, England	G	6.175 (via Antigua)

TO WESTERN NORTH AMERICA

TIME-PDT	TIME-GMT	STATION	QUAL*	FREQUENCIES, MHz
4:00-4:15 a.m.	1100-1115	Tokyo, Japan	P	5.99
4:00-5:25 a.m.	1100-1225	Trans-World Radio, Bonaire, N.A.	G	11.815
4:00-6:00 a.m.	1100-1300	London, England	G	5.99 (via Sackville), 6.195 (via Antigua)
4:00-7:00 a.m.	1100-1400	**VQA, Washington, USA	G	5.955, 9.73
		**AVEH, Cap-Haitien, Haiti	G	9.77, 11.835
5:00-5:15 a.m.	1200-1215	Tokyo, Japan	P	5.99
5:00-5:30 a.m.	1200-1230	**Tashkent, U.S.S.R.	F	9.60, 11.925
5:10-5:30 a.m.	1210-1230	**Santiago, Chile	F	6.195, 9.566, 11.81
5:15-5:30 a.m.	1215-1230	HCB, Quito, Ecuador	G	11.745
5:15-5:45 a.m.	1215-1245	Copenhagen, Denmark	F	15.165 (Sat.)
5:30-6:20 a.m.	1230-1320	Trans-World Radio Bonaire, N.A.	G	15.255 (Sat.), 1420 Sun.)
5:30-6:30 a.m.	1230-1630	HCB, Quito, Ecuador	G	11.745, 15.115
6:00-6:15 a.m.	1300-1315	Tokyo, Japan	P	5.99
6:00-6:30 a.m.	1300-1330	London, England	G	5.99 (via Sackville), 6.195 (via Antigua), 11.775 (via Antigua, Sat., Sun. from 1200)
6:30-6:50 a.m.	1330-1350	**Santiago, Chile	F	6.195, 9.566, 11.81
6:30-8:00 a.m.	1330-1500	**Delhi, India	F	17.81
7:00-7:30 a.m.	1400-1430	Tokyo, Japan	G	9.505
		**Tashkent, U.S.S.R.	G	9.60, 11.925
		**Hilversum, Holland	G	11.74 (via Talara)?
7:00-8:20 a.m.	1400-1520	Manila, Philippines (VQP)	F	9.58 (Closes 1555 Sun.)
7:00-9:55 a.m.	1400-1655	Tokyo, Japan	G	9.505
8:00-8:15 a.m.	1500-1515	London, England	G	17.84 (via Ascension)
8:00-9:00 a.m.	1500-1600	London, England	G	also 9.58 (via Sackville Sat., Sun.)
9:00-9:15 a.m.	1600-1615	Tokyo, Japan	G	9.505
9:04-9:56 a.m.	1604-1656	**Paris, France	G	9.58, 16.365 (via Sackville), 17.84 (via Ascension)
			G	11.705, 11.89, 11.93, 11.965, 15.20, 15.30, 15.425, 17.72, 17.80, 17.82, 17.85, (after Sept. 24; 1704-1756)
9:15-9:45 a.m.	1615-1645	Copenhagen, Denmark	F	15.165 (Sat.)
9:15-10:09 a.m.	1615-1709	London, England	G	9.58, 16.365
9:42-9:50 a.m.	1642-1650	Hilversum, Holland	G	15.19, 17.775 (all: 17.825; Mon., Fri., via Bonaire)
10:00-10:15 a.m.	1700-1715	Tokyo, Japan	G	9.505
10:00 p.m.-1:00 p.m.	1700-2000	**Kuwait, Kuwait	G	9.555, 12.085 (varies)
10:00-10:45 a.m.	1709-1745	London, England	G	15.365; Sat., Sun. also 9.58 (both via Sackville)
11:00-11:15 a.m.	1800-1815	Tokyo, Japan	G	9.505
11:00-11:30 a.m.	1800-1830	**Kampala, Uganda	F	15.325, (Tues., Thur., Sat., Sun.)
		Oslo, Norway	F	11.85, 15.175 (Sun.)
11:45 a.m.-1:00 p.m.	1845-2000	**Abidjan, Ivory Coast	G	11.92 (Sun.)
12 noon-12:10 p.m.	1900-1910	**Papeete, Tahiti	F	11.825, 15.17 (ext. Sun.)
12:00-12:15 p.m.	1900-1915	Tokyo, Japan	G	15.105
1:00-1:15 p.m.	2000-2015	Tokyo, Japan	G	15.105
1:00-2:20 p.m.	2000-2120	Hilversum, Holland	G	11.73 (via Talara)?
1:15-2:00 p.m.	2015-2100	**Kampala, Uganda	F	9.73 (Sun., Mon., Wed., Fri.)
1:30-1:50 p.m.	2030-2050	**Santiago, Chile	F	9.566, 11.81, 15.15
2:00-2:15 p.m.	2100-2115	Tokyo, Japan	G	15.105
2:00-3:00 p.m.	2100-2200	**Brasilia, Brazil	G	11.78 (alternates 15.245)
12:15-3:00 p.m.	2115-2200	London, England	F	9.58, 11.78
3:00-3:15 p.m.	2200-2215	Tokyo, Japan	G	15.105
3:00-4:30 p.m.	2200-2330	London, England	G	6.175, 9.51 (both via Sackville)
3:00-5:00 p.m.	2200-2400	**VQA, Washington, USA	G	17.82, 17.895, 21.61
		Montreal, Canada	F	5.96 (Mon., Fri.)
3:30-4:00 p.m.	2230-2300	Jerusalem, Israel	G	7.4125, 9.815, 11.655
3:30-4:20 p.m.	2230-2320	Johannesburg, S. Africa	G	5.98, 9.585, 11.90
3:30-6:30 p.m.	2230-0030	Moscow, U.S.S.R.	G	9.635, 12.05, 15.14, 15.18, 15.455, 17.72
3:50-4:10 p.m.	2250-2310	**Santiago, Chile	F	9.566, 11.81, 15.15
4:00-4:30 p.m.	2300-2330	Tokyo, Japan	G	15.105
		Vilnius, U.S.S.R.	G	9.61, 11.89, 15.10
4:30-6:00 p.m.	2330-0100	FEB, Manila, Philippines	F	17.81

4:30-8:30 p.m.	2330-0330	London, England	G	6.12 (via Sackville), 6.175 (via Antigua), 9.51 (via Sackville; from 0030, via Greenville), 9.58 (from 0030, via Ascension)
5:00-5:15 p.m.	0000-0015	Tokyo, Japan	G	15.105
5:00-6:00 p.m.	0000-0100	**VOA, Washington, USA	G	11.83, 11.895, 15.40
5:30-6:00 p.m.	0030-0100	Moscow, U.S.S.R.	G	9.635, 9.78, 12.05, 15.14, 15.18, 15.445
		Kiev, U.S.S.R.	G	9.81, 11.69, 15.10
5:40 p.m.-12 mdt.	0040-0700	H.C.J.B., Quito, Ecuador	G	6.095, 9.56, 11.915
6:00-6:15 p.m.	0100-0115	Tokyo, Japan	G	15.105
6:00-6:30 p.m.	0100-0130	Moscow, U.S.S.R.	G	9.635, 9.78, 12.05, 15.14, 15.455
6:00-7:00 p.m.	0100-0200	Taipei, Taiwan	F	15.425, 17.89
6:00-8:00 p.m.	0100-0300	Melbourne, Australia	G	15.32, 17.795
6:00-9:00 p.m.	0100-0400	Madrid, Spain	G	6.065, 11.88 (exc. Sun.)
6:10-6:30 p.m.	0110-0130	**Santiago, Chile	F	6.195, 9.566, 11.81, 15.15
6:30-7:00 p.m.	0130-0200	Moscow, U.S.S.R.	G	9.635, 9.78, 11.86, 12.05, 15.14, 15.455
6:30-7:30 p.m.	0130-0230	Tokyo, Japan	G	15.195, 15.42, 17.725, 17.825
7:00-8:00 p.m.	0200-0300	Moscow, U.S.S.R.	G	9.635, 9.735, 9.78, 11.86, 12.05, 15.14, 15.455
7:30-8:00 p.m.	0230-0300	Stockholm, Sweden	P	6.115, 9.695
8:00-8:15 p.m.	0300-0315	Tokyo, Japan	G	15.105
8:00-8:30 p.m.	0300-0330	Kiev, U.S.S.R.	G	9.58, 9.635, 9.78, 11.86
		Montreal, Canada	G	5.96, 6.00, 9.605, 9.655
		Moscow, U.S.S.R.	G	9.735, 12.05, 15.455
8:00-8:50 p.m.	0300-0350	Taipei, Taiwan	G	11.825, 15.345, 17.89
8:00-8:55 p.m.	0300-0355	Peking, China	G	7.12 (via Tirana) 9.46, 9.78 (via Tirana), 11.85, 12.055, 15.06, 17.53
8:00-9:20 p.m.	0300-0420	**Johannesburg, S. Africa	F	5.98, 7.27
8:10-8:30 p.m.	0310-0330	**Santiago, Chile	F	6.195, 9.566, 11.81, 15.15
8:20-9:25 p.m.	0320-0425	**TIFC, San Jose, Costa Rica	F	5.055, 6.035, 9.645, (opens 0300 Sat., Sun.)
8:22-8:28 p.m.	0322-0328	Erevan, U.S.S.R.	G	9.54, 11.69, 11.75, 15.14 (Sat./Tue./Wed./Fri.)
8:30-9:15 p.m.	0330-0415	Berlin, Ger. Dem. Rep.	P	5.955, 6.08, 9.73
8:30-9:30 p.m.	0330-0430	Moscow, U.S.S.R.	G	6.03, 6.07, 6.15, 6.185, 7.13, 7.175, 9.58, 9.635, 9.735, 9.78
8:30-10:00 p.m.	0330-0500	London, England	G	6.175 (via Antigua)
9:00-9:15 p.m.	0400-0415	Tokyo, Japan	G	9.505
9:00-9:30 p.m.	0400-0430	Oslo, Norway	F	11.87 (Sun.)
		Budapest, Hungary	F	6.00, 7.215, 9.585, 11.91 (Tue., Fri.)
		Montreal, Canada	G	5.96, 9.655
9:00-9:55 p.m.	0400-0455	Peking, China	G	11.65, 12.055, 15.06, 17.53
9:30-10:00 p.m.	0430-0500	Berne, Switzerland	G	6.045, 9.725
		Vienna, Austria	P	6.015
		Sofia, Bulgaria	G	7.115, (alternate 9.70, 9.53)
9:30 p.m.-12:30 a.m.	0430-0730	Moscow, U.S.S.R.	G	6.03, 6.07, 6.15, 6.185, 7.13, 7.175, 7.29, 9.58, 9.635, 9.735
10:00-10:15 p.m.	0500-0515	Jerusalem, Israel	F	5.90, 7.4125, 9.63, 9.82, 11.96, 12.045
		Tokyo, Japan	G	9.505
10:00-10:30 p.m.	0500-0530	Lisbon, Portugal	F	6.025, 11.935
10:00-11:20 p.m.	0500-0620	Hilversum, Holland	G	6.165, 9.715, (via Bonaire)†
10:00-11:30 p.m.	0500-0630	London, England	G	6.175, 9.51, (both via Antigua)
10:00 p.m.-12 mdt.	0500-0700	**Wellington, New Zealand	G	6.105, 9.54
10:30-10:50 p.m.	0530-0550	Cologne, Ger. Fed. Rep.	G	5.96 (via Antigua)
			G	6.10 (via Malta), 6.185, 9.545, 9.625 (via Montserrat)
11:00-11:15 p.m.	0600-0615	Tokyo, Japan	G	9.505
11:00-11:30 p.m.	0600-0630	Oslo, Norway	P	9.645, 11.87 (Sun.)
11:00 p.m.-12 mdt.	0600-0700	Buenos Aires, Argentina	G	9.69 (Mon., Fri.)
11:25 p.m.-1:55 a.m.	0625-0855	**Kuala Lumpur, Malaysia	G	9.75, 15.29
11:30 p.m.-12:30 a.m.	0630-0730	London, England	G	6.175 (via Antigua)
11:30 p.m.-12:50 a.m.	0630-0750	**Hilversum, Holland	G	9.63 (via Bonaire)†
11:30 p.m.-1:00 a.m.	0630-0800	Havana, Cuba	G	9.525
12:00-12:15 a.m.	0700-0715	Tokyo, Japan	G	9.505
12:00-3:30 a.m.	0700-1030	**Wellington, New Zealand	G	6.105
1:00-1:15 a.m.	0800-0815	Tokyo, Japan	G	9.505
1:00-3:00 a.m.	0800-1000	Manila, Philippines (VDP)	F	11.85
1:00-7:00 a.m.	0800-1400	**Port Moresby, Papua New Guinea	G	4.89
2:00-2:15 a.m.	0900-0915	Tokyo, Japan	G	9.505
2:30-2:50 a.m.	0930-0950	**Santiago, Chile	G	6.195, 9.566, 11.81
3:00-3:30 a.m.	1000-1030	Tokyo, Japan	G	5.99
3:00-3:50 a.m.	1000-1050	Pyongyang, Dem. P. Rep. Korea	G	7.203
3:50-4:10 a.m.	1050-1110	**Santiago, Chile	G	6.195, 9.566, 11.81

*Reception quality, East Coast (West Coast) location: G-good, F-fair, P-poor

**Not intended for North America, but receivable satisfactorily

†As of November, Radio Nederland, Hilversum, will reduce duration of English broadcasts from current 100 minutes to 50 minutes. Some starting times may change.

Days refer to local date in target area.

Use Quick-Wedge to fasten leads, wire in panelights, connect test equipment, install components

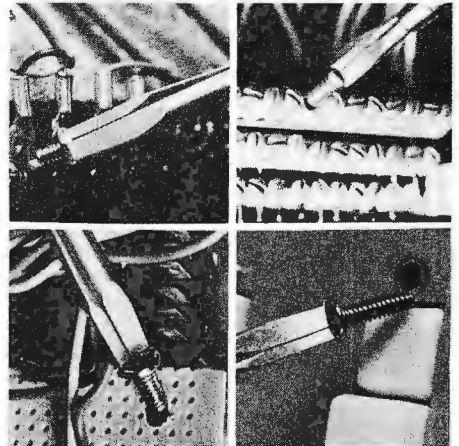

They do all that ordinary screwdrivers do, PLUS they hold and start the screw



QUICK-WEDGE 17 sizes

Screw-holding screwdrivers

Unconditionally guaranteed.

BUY A SET TODAY

See your dealer or write to:

Kedman Company, P.O. Box 25667, Salt Lake City, Utah 84125

CIRCLE NO. 36 ON FREE INFORMATION CARD

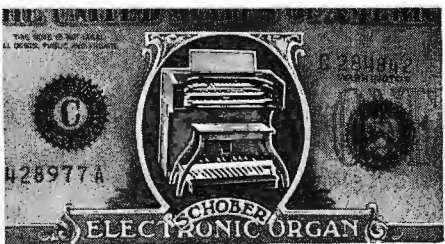

You can build a better organ than you can buy!

A magnificent Schober Electronic Organ

What a marvelous way to put your special talents to work! With our Schober Electronic Organ Kits and your skill, you can build yourself some very special satisfaction, and a lifetime of great music!

Schober Organs are literally far superior to comparably-priced "ready-made" units. You could actually pay twice as much and get no better organ...and miss the fun of assembling it yourself. A PC board at a time, component by component, you'll assemble your own "king of instruments." And when you're done, you'll wish there was more to do. And there is! For then, Schober will help you learn to play, even if you've never played a note before!

Schober Organ Kits range from \$650 to \$2850, and you can purchase in sections to spread costs out...or have two-year time payments.

Just send the coupon for the fascinating Schober color catalog (or enclose \$1 for a record that lets you hear as well as see Schober quality.)

**The Schober Organ Corp., Dept. PE-72
43 West 61st Street, New York, N.Y. 10023**

Please send me Schober Organ Catalog.
 Enclosed please find \$1.00 for 12-inch L.P. record of Schober Organ music.

NAME _____

ADDRESS _____

CITY _____ STATE _____ ZIP _____

CIRCLE NO. 56 ON FREE INFORMATION CARD

PRICE WAR

AMERICA'S #1 VALUE LEADER
STEREO CORPORATION OF AMERICA



AUDIO DISCOUNTING STARTED IN NEW YORK & NOW WITH THE END OF FAIR-TRADE WE ARE SURE THAT NO ONE CAN BEAT OUR PRICES:

- WE DISCOUNT OVER 60 MAJOR BRANDS
- OVER 10 YEARS OF RELIABLE SERVICE IN THE MAIL ORDER FIELD.
- LARGEST INVENTORY/LOWEST PRICES! WE GET THE BEST DEALS FROM THE MANUFACTURERS; YOU GET THE BEST DEAL FROM US. DON'T DELAY!!!

WRITE US NOW FOR LOWEST PRICE QUOTE

WRITE OR CALL For FREE STEREO PRICE CATALOG

SHOP BY PHONE! (212) 253-8888 N.Y. TIME 9-5 MON. THRU SAT. Mastercharge/BankAmericard

STEREO CORPORATION OF AMERICA



P-E 1629 Flatbush Ave., Brooklyn, New York 11210



CIRCLE NO. 67 ON FREE INFORMATION CARD

Operation Assist

If you need information on outdated or rare equipment—a schematic, parts list, etc.—another reader might be able to assist. Simply send a postcard to Operation Assist. POPULAR ELECTRONICS, 1 Park Ave., New York, NY 10016. For those who can help readers, please respond directly to them. They'll appreciate it. (Only those items regarding equipment not available from normal sources are published.)

United States Radio and TV Corp. "Neutrodyne" electric receiver (chassis 41—circa 1920's). Schematic diagram and parts list. John C. Whybrew, Box 387, Upland, IN 46989.

Heathkit Model 05 oscilloscope. Need service manual or any repair information. Andy Foremiak, Box 224, North Tonawanda, NY 14120.

Zenith combination AM, FM100, FM45 and 78 record player (chassis #8C21). Schematics and parts list or service manual. Dennis Main, Rt. 6, Box 218, Muncie, IN 47302.

Paco Model S-50 push-pull oscilloscope. Schematics and/or parts source. G. Denman, Rt. 3 Box 164, Grapeland, TX 75844.

Standard Model SR-500U AM/FM stereo receiver. Need H-203 IC (Sanyo part number LD 3141). William F. Gerdes, 732 Bowen St., Oshkosh, WI. 54901.

Waterman Model S-14-B oscilloscope. Manual or schematic. **Xam Mark 2TA** solid-state stereo amplifier. Output transistor number and/or schematic. John Schmitt, Jr., 16 Carlson Parkway, Cedar Grove, NJ 07009.

Weston Model 802 VU meter. Need source to match replacement in Dumont 137-P mixer. Rich Adams, 2303 Du-laire Rd., Greensboro, NC 27407.

Tektronix Type 315R oscilloscope. Schematic and/or operation manual. Tom Ramos, 2813 15th Ave. So., Minneapolis, MN 55407.

Bradford Model 51847 multiband portable radio. Schematic and/or service manual. Rex Faulkner, 2677 Estelle Ct., Smyrna, GA 30080.

Friden Model 130 calculator, **Triumph Model 850** oscillograph, **Superior Instruments Model TV-50A** "Genometer" signal generator, **Lear vhf-lf** receiver, **LRA-6A** lf receiver and **RT-10E** transmitter, and **Omnirange Model 2214A** converter. Schematics, operation manuals and service information. James Marple, 2801 Sequoia Ln., Arlington, TX 78010.

Trio Model 9R-59D radio. Operation manual needed. Ed Davis, 831 N. Superior Ave., Decatur, GA 30033.

Hallicrafters Model S-22R (U.S. Navy version). Schematic and any other available information. T. Thompson, 330 Sunset Blvd. S.W. #19, Renton, WA 98055.

Hammarlund Model CB-23 transceiver. Schematic and/or service manual. E.R. Stutler, 934 Edison Ave., New Port Richey, FL 33552.

RCA Model WO-56A oscilloscope and **Dumont Type 304A** oscilloscope. Schematic and/or service calibration data. Mr. James A. Fillingham, Rte. 1 Box 380-A, Pelzer, SC 29669.

Philco Model 39-7 radio/phono combination console. Any available information. Don Sherr, 509 Hannes St., Silver Spring, MD 20901.

Nipon Model 141-DA "Basicom" electronic calculator. Schematic needed. Dale Williams, 134 Stage Rd., Newport News, VA 23606.

Bogen Model CHB-100 PA amplifier. Schematic, parts list or manual. Brian Burke, 5737 S. Maryland, Chicago, IL 60637.

Hammarlund Model HQ-100 receiver. Schematic, alignment information or any available data. Jeff Kientz, 15 E. Forest, Columbia, MO 65201.

Sencore "Caddy" bar generator. Owners manual needed. Wilbur Hostetter, 12472 136th St., Largo, FL 33540.

Accurate Instrument Co. Model 157 tube tester. Operating instructions needed. Ralph A. Ladnier, 4026C FCN, McGuire AFB, NJ 08641.

Grundig Model 8034-3435 (chassis #2) stereo record player. Schematic diagram needed. M.A.H. Siddiqi, 2121 N. Western Ave., Chicago, IL 60647

Precise Model 30 oscilloscope. Need operating instructions. Anthony Vilale, 5222 9th Ave., Brooklyn, NY 11220.

Treat yourself to a new direct reading DVM today.



DVM35

POCKET PORTABLE
ANALOG REPLACEMENT
3-digit, 1% DCV
Battery or AC
Only \$134



DVM36

LAB ACCURATE
POCKET PORTABLE
3½ digit, .5% DCV
Battery or AC
Only \$158

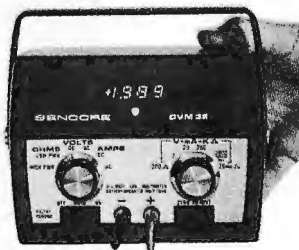

DVM32

BENCH & FIELD MASTER
3½ digit, .5% DCV
Battery or AC
Only \$198

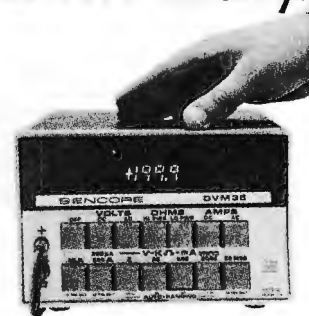

DVM38

"PRIME" STANDARD AT
YOUR FINGERTIPS
3½ digit, .1% DCV
Auto-Ranging
Only \$348

A COMPLETE LINE OF DVMs TO FILL YOUR EVERY NEED OR WANT.

You can be sure more times in more circuits, under more adverse conditions, with greater versatility, accuracy, and meter protection than any other digital multimeters on the market today; and for less money, too. 10 Day Free Trial: Try any of these famous DVMs for 10 days. If the DVMs in use don't prove exactly what we say, return them to your Sencore FLPD Distributor.

SENCORE

Want more information? We would like to tell you all about the Sencore DVMs by sending you a 24-page Sencore News, a six-page brochure, and the name of your nearest Sencore Distributor today... simply write or circle reader's service number.



3200 Sencore Drive, Sioux Falls, SD 57107

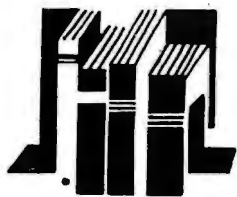

Electronics Library

110 CMOS DIGITAL IC PROJECTS

by R.M. Marston

If the schematics and typeface look a little different, it's because this book was first published in England. After a short introduction to COSMOS, the 110 projects are divided into six chapters of increasing complexity: 15 inverter, gate and logic circuits, 25 multivibrators, 10 dc lamp control, 25 relay switching, 25 sound generator and alarm, and 15 counting and dividing circuits. Nearly every circuit uses the RCA CD4001 quad 2-input NOR gate (same as Motorola MC14001); though the CD4013 dual D-type flip-flop (Motorola MC14013) is used a couple of times.

Published by Hayden Book Co., 50 Essex St., Rochelle Park, NJ 07662. 114 pages. \$4.95 soft cover.

ARRL HAM RADIO OPERATING GUIDE

by the ARRL Headquarters Staff

This operating manual introduces the reader to the many different operating practices and interests within the hobby of amateur radio. It contains ten chapters, entitled: Getting Started; Message Handling—Fun with a Purpose; Contests—a Sure Way to Sharpen Skills; The Basic Intrigue of DX; Logging + QSLing = Awards; Repeaters—All the Ins and Outs; The Flea-Power Challenge; Communicating Visually; Vhf/uhf—Searching for New Horizons; Oscar—the New Frontier. Included are tips on operating frequencies, propagation conditions on each band, power levels, and a helpful appendix.

Published by the American Radio Relay League, 225 Main Street, Newington, CT 06111. 128 pages (8 1/4" x 11"). \$4.00 in the USA and possessions, \$4.50 elsewhere (soft cover).

LIGHT-BEAM COMMUNICATIONS

by Forrest Mims, III

The use of light beams to convey information is covered in this book. The history of the science is traced from primitive signal fires to sophisticated laser-beam communications links. Modern systems are covered by analysis of modulators, transmitters, detectors, transmission lines (fibre optics and waveguides), carrier sources, receivers, and "antennas." Atmospheric absorption is also discussed. The final chapter highlights experimental and operational systems developed since 1960.

Published by Howard W. Sams & Co., 4300 W. 62nd St., Indianapolis, IN 46206. 160 pages. \$4.95 soft cover.

POPULAR ELECTRONICS



Revolutionary! Sound-shaping taping mike.

Never before — a single microphone that gives you the versatility of 16 microphones! Four tiny frequency filter switches built into the new Shure 516EQ E-Qualidyne Microphone let you tailor sound for studio effects in virtually any recording situation: flick a switch to add sizzle

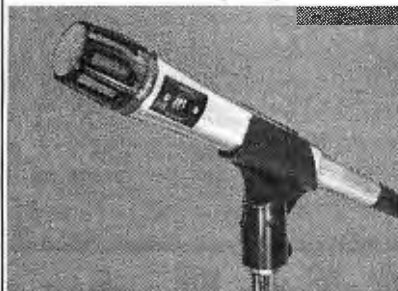

to vocals . . . flick another switch to highlight the sound of a bass drum. You can even compensate for the acoustic response of a room — right from the microphone! In all, the 516EQ creates 16 different response variations that can add a new, professional sound to every tape you make. Available singly or in pairs for stereo recording. Ask to hear a recorded demonstration at your participating Shure dealer.

Shure Brothers Inc.
222 Hartrey Ave., Evanston, IL 60204
In Canada: A. C. Simmonds & Sons Limited



Manufacturers of high fidelity components, microphones, sound systems and related circuitry.

CIRCLE NO. 69 ON FREE INFORMATION CARD

ELECTRONICS MARKET PLACE

REGULAR CLASSIFIED: COMMERCIAL RATE: For firms or individuals offering commercial products or services, \$2.25 per word. Minimum order \$33.75. **EXPAND-AD CLASSIFIED RATE:** \$3.35 per word. Minimum order \$50.25. Frequency discount; 5% for 6 months; 10% for 12 months paid in advance. **READER RATE:** For individuals with a personal item to buy or sell, \$1.35 per word. No minimum! **DISPLAY CLASSIFIED:** 1" by 1 column (2-1/4" wide), \$260.00. 2" by 1 column, \$520.00. 3" by 1 column, \$780.00. Advertiser to supply film positives. For frequency rates, please inquire.

GENERAL INFORMATION: Payment must accompany copy except when ads are placed by accredited advertising agencies. First word in all ads set in caps. All copy subject to publisher's approval. All advertisers using Post Office Boxes in their addresses **MUST** supply publisher with permanent address and telephone number before ad can be run. Advertisements will not be published which advertise or promote the use of devices for the surreptitious interception of communications. Ads are not acknowledged. They will appear in first issue to go to press after closing date. Closing Date; 1st of the 2nd month preceding cover date (for example, March issue closes January 1st. Send order and remittance to **POPULAR ELECTRONICS**, One Park Avenue, New York, New York 10016. Attention: Hal Cymes.

FOR SALE

FREE! Bargain Catalog—I.C.'s, LED's, readouts, fiber optics, calculators parts & kits, semiconductors, parts. Poly Paks, Box 942PE, Lynnfield, Mass. 01940.

GOVERNMENT and industrial surplus receivers, transmitters, snooperscopes, electronic parts, Picture Catalog 25 cents. Meshna, Nahant, Mass. 01908.

LOWEST Prices Electronic Parts. Confidential Catalog Free. KNAPP, 3174 8th Ave. S.W., Largo, Fla. 33540.

ELECTRONIC PARTS, semiconductors, kits. FREE FLYER. Large catalog \$1.00 deposit. BIGELOW ELECTRONICS, Bluffton, Ohio 45817.

RADIO—T.V. Tubes—36 cents each. Send for free catalog. Cornell, 4213 University, San Diego, Calif. 92105.

AMATEUR SCIENTISTS, Electronics Experimenters, Science Fair Students... Construction plans—Complete, including drawings, schematics, parts list with prices and sources... Robot Man — Psychedelic shows — Lasers — Emotion/Lie Detector — Touch Tone Dial — Quadraphonic Adapter — Transistorized Ignition — Burglar Alarm — Sound Meter... over 60 items. Send 50 cents coin (no stamps) for complete catalog. Technical Writers Group, Box 5994, University Station, Raleigh, N.C. 27607.

METERS—Surplus, new, used, panel or portable. Send for list. Hanchelt, Box 5577, Riverside, CA 92507.

MECHANICAL, ELECTRONIC devices catalog 10 cents. Greatest Values — Lowest Prices. Fertik's, 6249 "D", Philadelphia, Pa. 19120.

POLICE/Fire scanners, large stock scanner crystals, antennas. Also CBs. Harvey Park Radio, Box 19224, Denver, CO 80219.

TELETYPE EQUIPMENT for sale for beginners and experienced computer enthusiast. Teletype machines, parts, supplies. Catalogue \$1.00 to: ATLANTIC SALES, 3730 Nautilus Ave., Brooklyn, NY 11224. Tel: (212) 372-0349.

ELECTRONIC Ignition: Capacitor-Discharge, pointless. Auburn Sparkplugs. Wheel Stabilizers. Information 20 cents. Anderson Engineering, Epsom, N.H. 03234.

WHOLESALE C.B., Scanners, Antennas, Catalog 25 cents. Crystals: Special cut, \$4.95, Monitor \$3.95. Send make, model, frequency. G. Enterprises, Box 461P, Clearfield, UT 84015.

COMPUTER HOBBYISTS—classified advertising newsletter. \$3.75/year. Free Sample. ON LINE, 24695 Santa Cruz Hwy., Los Gatos, CA 95030.

SOUND SYNTHESIZER KITS—Surf \$12.95, Wind \$12.95, Wind Chimes \$17.95, Electronic Songbird \$6.95, Musical Accessories, many more. Catalog free. PAIA Electronics, Box J14358, Oklahoma City, OK 73114.

BUGGED??? New locator finds them fast. Write, Clifton, 11500-L N.W. 7th Avenue, Miami, Florida 33168.

YOU WILL SAVE BIG MONEY! Surplus, Clearouts, Bankruptcy, Inventory, Deals. Catalog \$1 (redeemable). ETCOA Electronics, Box 741, Montreal, H3C 2V2. U.S. Inquiries.

HEAR POLICE/FIRE Dispatchers! Catalog shows exclusive directories of "confidential" channels, scanners. Send postage stamp. Communications, Box 56-PE, Commack, N.Y. 11725.

UNSCRAMBLERS: Fits any scanner or monitor, easily adjusts to all scrambled frequencies. Only 4" square \$29.95, fully guaranteed. Dealer inquiries welcomed. PDQ Electronics, Box 841, North Little Rock, Arkansas 72115.

RECONDITIONED Test Equipment. \$0.50 for catalog. Walter's Test Equipment, 2697 Nickel, San Pablo, CA 94806.

CARBON FILM RESISTORS 1/4W, 1/2W - 1.7 cents each. FREE sample / specifications. Other components. COMPONENTS CENTER, Box 134P, New York, N.Y. 10038.

RADAR DETECTOR KIT. Build a long range radar detector with over one mile range. Kit comes with complete documentation and drilled, etched and plated PC board. Only \$4.95. Thousands sold nationally. Satisfaction guaranteed. Same day shipment. J.B. Saunders Company, 3050 Valmont, Boulder, Colorado 80301.

BUILD YOUR OWN SPEAKERS AND SAVE UP TO 50%

Send for our free, fact-packed 44-page catalog/manual and learn how to assemble your own multi-element stereo speakers from scratch or from kits. Our catalog includes chapters on design, construction, x-overs, enclosures, midranges, woofers, tweeters and horns. Write us today!

SPEAKERLAB
Dept. PE-A, 5500 35th N.E.
Seattle, Washington 98105



LINEARS				CMOS				CMOS				CMOS				TEXAS INSTRUMENTS I.C. SOCKETS (Low Profile Solder Tail)				
SH0002CH	LH0002CH	5.40	LM710CH	.55	LM3018H	1.10	CD4000BE	.13	CD4052BE	1.15	74C14/40014PC	.75	Description Unit Price							
SH2001CH		5.55	LM711CH	.55	LM3046N-14	.52	CD4001BE	.16	CD4053BE	.89	74C85/40085PC	1.20								
LM300H		.79	LM715CH	3.85	LM3086	.59	CD4002BE	.16	CD4055BE	1.29	80C97/40097PC	.65	8 Pin DIL (C840802) .15							
LM301AH		.39	LM720CN-14	.79	LM3089	1.98	CD4006BE	.99	CD4060BE	.99	80C98/40098PC	.65	14 Pin DIL (C841402) .18							
LM301AN-8	(Mini Dip)	.29	LM723CH	.48	LM3302N	.65	CD4007BE	.16	CD4066BE	.59	74C160/40160PC	1.50	16 Pin DIL (C841602) .19							
LM302H		2.25	LM723CN-14	.43	LM3401N	.65	CD4008BE	.80	CD4068BE	24	74C161/40161PC	1.50	18 Pin DIL (C841802) .29							
LM304H		.79	LM725CH	2.40	LM3403N	1.20	CD4009BE	.37	CD4069BE	.24	74C162/40162PC	1.50	20 Pin DIL (C842002) .35							
LM305H		.79	LM726CH	6.50	LM3900N	.54	CD4010BE	.37	CD4070BE	.24	74C163/40163PC	1.50	22 Pin DIL (C842202) .34							
LM306H		1.10	LM727CH	11.95	LM4136N	1.20	CD4011BE	.16	CD4071BE	.24	74C174/40174PC	1.40	24 Pin DIL (C842402) .34							
LM307H		.36	LM733CN-14	.95	RC4131N-8	(Mini Dip) .80	CD4012BE	.16	CD4072BE	.29	74C175/40175PC	1.40	28 Pin DIL (C842802) .34							
LM307N-8	(Mini Dip)	.35	LM734CN-14	2.75	RC4151N-8	(Mini Dip) 5.00	CD4013BE	.29	CD4073BE	.29	74C192/40192PC	1.50	40 Pin DIL (C844002) .65							
LM308H		.89	LM739CN-14/LM381	.99	8700CJ	9.65	CD4014BE	.74	CD4075BE	.29	74C193/40193PC	1.50								
LM308N		.79	LM740CH/NE536T	8.95	8701CN	22.85	CD4015BE	.74	CD4076BE	.98	74C194/40194PC	1.40								
LM309H		.79	LM741CH	.37	8702CN	29.50	CD4016BE	.29	CD4078BE	.24	74C195/40195PC	1.40								
LM309K	(T03)	1.45	LM741CN-14	.33	8703CJ	11.10	CD4017BE	.79	CD4081BE	.24										
LM310H		1.25	LM741CN-8	(Mini Dip) .25	8704CJ	13.95	CD4018BE	.79	CD4082BE	.29	SG3501AT	3.60	±5V Dual Tracking Regulator							
LM311H		.79	LM747CN-14	.49	8705CN	29.50	CD4019BE	.38	CD4085BE	.75	SG3524J	7.25	Switching Regulator Converter							
LM312H		1.55	LM747CH	.59	8705CN	29.50	CD4020BE	.84	CD4086BE	.75	SG4501T	1.80	±15V Dual Tracking Regulator							
LM318H		1.25	LM748CN-8	(Mini Dip) .35	8750CJ	11.50	CD4021BE	.89	CD4088BE	1.15	RC4194TK	3.95	Variable Dual Tracking Regulator ±35V ±9.5V							
LM323K		5.60	LM748CH	.36	SN72L044N	2.30	CD4022BE	.89	CD40507BE	.39	RC4195T	2.35	Fixed ±15V Dual Tracking Regulator T05							
LM324N		.79	LM749CN-14	1.25	TL080CP	1.49	CD4023BE	.16	CD4510BE	1.05	RC4195TK	3.15	Fixed ±15V Dual Tracking Regulator T066							
LM339N		.79	LM750CN-14	3.25	TL081CP	.69	CD4024BE	.67	CD4511BE	1.25	78H05KC	6.35	5 Amp 5 Volt Positive Regulator T03							
LM341H		.99	LM776CH	3.25	TL082CP	1.29	CD4025BE	.16	CD4512BE	.69	7800 Series	.99	Positive Voltage Regulators (Plastic) ± amp							
LF355L		1.49	LM777CH	2.00	TL083CN	1.65	CD4026BE	1.39	CD4514BE	2.50	T0-220 / LM340T	1.39	Positive Voltage Regulator 1/2 Amp							
LF356L		1.49	LM791KC	12.75	TL084CN	1.69	CD4027BE	.78	CD4515BE	2.50	T0-5 / LM340H	1.49	Positive Voltage Regulator 1 Amp							
LF357L		1.75	LM796CH/MC1496G	1.10	TL089CL/HA2905	14.50	CD4028BE	.74	CD4516BE	.84	7800 Series	1.49	Positive Voltage Regulator 100 MA							
LM358P		.65	LM1312N-14	1.98	TL182CN/DG182	1.98	CD4029BE	.78	CD4518BE	.84	T0-3 / LM340K	.29	Positive Voltage Regulator 4 Terminal							
LM376N-8	(Mini Dip)	.99	LM1436CH	1.78	TL185CN/DG185	1.98	CD4030BE	.37	CD4519BE	.79	78L00 AWC Series	2.9	Dual In Line Adjustable 4 Terminal Positive Voltage Regulator							
LM393P		.75	LM1437N-14	.45	TL188CN/DG188	1.50	CD4033BE	1.60	CD4520BE	.79	T0-92	1.25	Negative Voltage Regulator 1 Amp							
LM555N-8	(Mini Dip)	.34	LM1458H	.72	TL191CN/DG191	1.98	CD4034BE	2.95	CD4522BE	1.98	7900 Series	1.25	Negative Voltage Regulator 1/2 Amp							
LM556N-14		.75	LM1458N-8	(Mini Dip) .48	TL497CN	1.98	CD4035BE	.98	CD4526BE	1.50	T0-220 / LM320T	1.35	Negative Voltage Regulator 1 Amp							
LM702CH		.69	ULN1488D	1.25	ULN2001AN	1.10	CD4040BE	.99	CD4527BE	1.50	79M00 Series	1.35	Negative Voltage Regulator 20 Amp							
LM706APC		1.75	ULN1489D	1.25	ULN2002AN	1.10	CD4041BE	.67	CD4528BE	1.20	T0-5 / LM320H	1.75	Negative Voltage Regulator 1 Amp							
LM709CN-8	(Mini Dip)	.37	ULN1489AD	1.25	ULN2003AN	1.10	CD4042BE	.58	CD4531BE	1.25	7900 Series	1.75	Negative Voltage Regulator 1 Amp							
LM709CN-14		.28	ULN1495N-14	1.49	ULN2004AN	1.10	CD4043BE	.45	CD4539BE	1.20	T0-3 / LM320K	1.20	Dual In Line Adjustable 4 Terminal Positive Voltage Regulator							
LM709CH		.40	LM1496N-14	.99			CD4044BE	2.45	CD4555BE	.75	78MGT2C	1.20	Dual In Line Adjustable 4 Terminal Positive Voltage Regulator							
							CD4046BE	2.45	CD4556BE	.75	79MGT2C	1.20	Dual In Line Adjustable 4 Terminal Negative Voltage Regulator							
							CD4047BE	2.45	CD4581BE	2.25			78GU1 TO 220 1.45 79GU1 TO 220 1.25 78KC TO 3 1.80 79KC TO 3 2.10							
							CD4049BE	.34	CD4582BE	.95			1 Amp Adjustable Positive Voltage Regulator 1 Amp Adjustable Positive Voltage Regulator 1 Amp Adjustable Positive Voltage Regulator 1 Amp Adjustable Negative Voltage Regulator							
							CD4050BE	.34	CD4585BE	1.80										
							CD4051BE	.89												

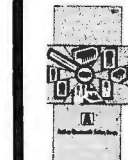

Our new comprehensive 1977 Fall Catalogue, listing complete descriptions, illustrations and special monolithic pricing on over 10,000 items, is now available on request.

Active Electronic Sales Corp.

P.O. BOX 1035 FRAMINGHAM, MASSACHUSETTS 01701
Telephone Orders & Enquiries (617) 879-0077 New Catalogue available on request
NOW IN CANADA 5647 Ferrier st. 44 Fasken Dr Unit 25
Montreal, Quebec Rexdale, Ontario
2 Locations Tel. (514) 735-8429 Tel. (416) 677-4287

7400 TTL

7400	.21	7442	1.08	74121	.55
7401	.21	7448	1.15	74122	.49
7402	.21	7450	.26	74123	1.05
7404	.21	7451	.27	74125	.60
7405	.24	7453	.27	74126	.81
7406	.45	7454	.41	74132	3.00
7407	.45	7460	.22	74141	1.15
7408	.25	7472	.39	74150	1.10
7409	.25	7473	.45	74151	1.25
7410	.20	7474	.45	74153	1.35
7411	.30	7475	.80	74154	1.25
7413	.85	7482	1.75	74155	1.21
7416	.43	7483	1.15	74157	1.30
7417	.43	7485	1.12	74161	1.45
7420	.21	7486	.45	74164	1.65
7422	1.50	7489	2.49	74165	1.65
7423	.43	7490	.69	74166	1.70
7427	.37	7491	1.20	74174	.95
7428	.33	7492	.82	74175	1.95
7430	.26	7493	.82	74180	1.05
7432	.31	7494	.91	74181	3.55
7437	.47	7495	.91	74191	1.50
7438	.40	7496	.91	74195	1.00
7440	.21	74100	1.25	74197	1.00
7441	1.10	74107	.49	74298	1.30

74L SERIES TTL

74L00	.33	74LS04	.45	74LS113	.98
74L10	.33	74LS10	.39	74LS138	1.89
74L30	.33	74LS20	.39	74LS174	2.50
74L42	1.50	74LS51	.39	74LS386	5.50
74L86	6.90	74LS74	.65	74LS153	2.25
74LS00	.39	74LS112	.65	74S387	1.95

74H00 TTL

74H00	.33	74H11	.33	74H53	.39
74H01	.33	74H20	.33	74H55	.39
74H03	.33	74H21	.33	74H73	.59
74H04	.35	74H30	.33	74H74	59
74H10	.33	74H40	.33	74H76	60

ELECTROLYTIC CAPACITORS

2.2MF50	AXIAL LEADS	.15
3.3MF10	AXIAL LEADS	.15
3.3MF10	NO POLARITY	.15
10MF25	AXIAL LEADS	.15
10MF150	AXIAL LEADS	.20
25MF35	AXIAL LEADS	.20
30MF25	AXIAL LEADS	.15
47MF25	RADIAL LEADS	15
47MF50	RADIAL LEADS	20
100MF16	RADIAL LEADS	.15
100MF25	RADIAL LEADS	.20
500MF50	AXIAL LEADS	.60
1000MF35	AXIAL LEADS	.65

CARBON RESISTORS
Minimum 5 Pcs Per Value

QUANTITY		
PRICING	5-25	30-95 100-495
1/4W5%	06	05 04
1/2W5%	08	07 06
STANDARD RESISTANCE VALUES		
OHMS	270	820 4.7K 27K
	330	910 5.1K 33K
	470	1.5K 6.8K 47K
	510	2.2K 7.5K 100K
	560	2.7K 10K 1.0M
	680	3.3K 15K
	750	3.9K 22K

5400 SERIES

5400	1.00	5475	1.50
5404	1.25	5486	1.90
5410	1.00	5493	2.00
5426	1.25	54100	1.80
5473	1.50	54LS04	1.00

C MOS

4001AE	29	4022AE	1.20
4002AE	29	4023AE	.29
4007AE	29	4024AE	1.50
4009AE	58	4025AE	35
4010AE	58	4026AE	1.49
4011AE	59	4028AE	1.60
4012AE	29	4029AE	2.90
4013AE	52	4030AE	6.5
4015AE	1.25	4037AE	4.50
4018AE	65	4040AE	2.40
4019AE	65	4047AE	2.75
4020AE	1.75	4048AE	75
4021AE	1.50	4050AE	75

MOTOROLA CIRCUITS

MC725P	150	MC1804P	98
MC740L	155	MC1806P	98
MC790P	150	MC1810P	98
MC832P	48	MC2053L	45
MC1004L	125	MC3004L	1.32
MC1008L	125	MC3006P	1.44
MC1010L	125	MC3007P	1.32
MC1011L	125	MC3021P	2.15
MC1036L	1250	MC3021P	2.15
MC1037L	1250	MC3060L	2.65
MC1352P	1.05	MC3062L	3.00
MC1406CP	3.95	MC4024P	2.20
MC1468L	2.90	MC14501CP	3.1
MC1469R	2.50	MC14502CP	1.18
MC1510G	8.00	MC14507CP	8.2
MC1514L	4.50	MC14510CP	2.40
MC1520P	1.50	MC14511CP	2.76
MC1558	4.37	MC14512CP	1.92
MC1595L	6.25	MC14519CG	94
MC1596G	3.31	MC14528CP	1.74
MC1723CG	1.25	MC4044P	4.80

POSITIVE VOLTAGE REGULATORS

LM340K-5	1.95
LM340K-6	1.95
LM340K-8	1.95
LM340K-12	1.95
LM340K-15	1.95
LM340K-18	1.95
LM340K-24	1.95
LM340T0-5	1.75
LM340T0-6	1.75
LM340T0-12	1.75
LM340T0-15	1.75
LM340T0-18	1.75
LM340T0-24	1.75

REGULATOR AVAILABLE

JAPANESE CIRCUITS

AN136	2.90	HA1312	4.05	STK056	11.35	TA7201P	6.40
AN203	3.75	HA1322	5.20	STK415	11.50	TA7203P	7.00
AN208	4.75	HA1339	5.20	TA7045M	3.50	TA7204P	6.50
AN210	3.10	LA1201	4.25	TA7054P	3.05	TA7205P	6.50
AN211	3.30	LA1364	4.70	TA7055P	5.50	TA78005M	2.50
AN214	4.90	LA1366	6.00	TA7060P	1.85	TA78005P	1.95
AN217	3.30	LA1367	5.90	TA7061P	2.25	TA78012M	2.50
AN229	6.35	LA3301	4.85	TA7149P	4.00	TA78012P	1.95
AN234	5.75	LA4030	4.85	TA7083P	2.25	TA78015M	2.50
AN239	6.50	LA4031P	3.50	TA7074P	4.90	TA78015P	1.95
AN241	3.20	LA4051P	4.65	TA7075P	4.90	TC9100P	12.00
AN245	6.50	T8A905	3.50	TA7076P	4.55	UPC16C	2.50
AN274	3.95	LD3080	4.00	TA7102P	2.90	UPC20C	5.00
AN277B	3.40	LD3120	3.10	TA7106P	3.25	UPC41C	3.95
AN288	4.00	LD3141	2.40	TA7120P	3.25	UPC85C	3.95
AN328	4.05	M5112	5.40	TA7120P	2.20	UPC554C	3.90
AN343	3.90	M5155PR	4.80	TA7120P-C	2.20	UPC556H2	8.00
BA511	3.50	M5155	2.85	TA7122AP	2.30	UPC566H	2.25
BA521	3.95	SG613	5.40	TA7124P	1.85	UPC575C	4.10
HA1158	6.30	STK011	10.50	TA7146P	1.45	UPC100H12	5.15
HA1159	6.60	STK015	6.50	TA7159P	4.55	UPC1020H	5.50
HA1202	3.10	STK025	12.50	TA7153P	6.90	UPC1025	5.50
HA1306W	5.20	STK032	14.20	TA7200P	6.25		

IC'S ON THE MOVE

BBD BUCKET BRIGADE DEVICE					
MM3001	19.50	MM3002	11.70	MM3003	9.45
HALL IC	DN834	1.25	DN837	1.55	
	DN835	1.35	DN838(NEW)		
SN76001	1.75	SN76002	1.95		
PLL02A	MIDLAND	PHASE LOCK LOOP	12.00		

MICROPROCESSOR CHIPS

I404A	3.25	2102	2.50	MM5013	3.25
C1702A	19.95	C2708	95.00	8008	19.95
2101	6.95	C4702A	19.95	8008A	29.95
MK4200 P-11	4096x1 Bit Dynamic Ram				9.95
C5101-3	1024 Bit (256x4) Static C-Mos Ram				4.50
MC14514	4 Bit Latch + 1 to 16 Line Decoder				4.25

CALL OR WRITE FOR FURTHER INFORMATION, SPEC'S AVAILABLE

HOBBY SPECIALS

YOU TEST 'EM SAVE BIG MONEY

Power Pac	100 Asst (includes Case T03, T066)	\$2.99
Transistor/Diode Pac	100 Asst (includes Case T05, T039, T018, D07, 0041)	\$1.99
I.C. Pac	100 Asst (includes 14 & 16 Pin)	\$3.50
Resistor Pac	50 Asst (Assorted values)	\$1.50
Mos Fet Pac	10 Asst (many top #'s Case T072)	\$0.99
SCR Pac	100 Asst (similar to C103 Series) Case to 92, VR 10-100V, I:400MA, IGT:200MA	\$4.00

ZENER DIODES
1/2 & 1 Watt 10% .30 each UP TO 33V.
GREATER THAN 33V CALL FOR PRICING

PAGE/PATHCOM PART #'S

130079	4.00	IP20-0123	2.75
1300821	.65	IP20-0131	2.50
13-0122	1.75	IP20-0141	3.00
83-0003	2.00	IP20-0142	3.00
83-0007	2.50	IP20-0139	.43
83-0008	2.00	IP20-0155	6.00
83-0015	3.00	IP20-0158	2.50
IP20-0005	3.00	IP20-0161	4.00
IP20-0016	4.00	IP20-0177	2.75
IP20-0034	.85	IP20-0176	2.85
IP20-0037	.85	IP20-0191	.72
IP20-0045	.20		
IP20-0073	2.75		
IP20-0093	2.50		

JAPANESE TRANSISTORS * CB, AUDIO, INDUSTRIAL

2SA52	60	2SC206	1.00	2SC774	1.75	2SC1173	.95	2SD77	1.00
2SA316	.75	2SC240	1.10	2SC775	2.75	2SC1175	.65	2SD81	3.25
2SA473	.75	2SC291	.65	2SC776	3.00	2SC1209	.55	2SD88	1.50
2SA483	1.95	2SC292	3.00	2SC777	4.00	2SC1213	.75	2SD118	3.25
2SA489	.80	2SC320	.75	2SC778	4.00	2SC1226A	1.25	2SD130	1.25
2SA490	.70	2SC352	.75	2SC781	3.00	2SC1237	4.50	2SD141	2.25
2SA505	.70	2SC353	.75	2SC783	1.00	2SC1239	4.00	2SD151	2.25
2SA564	.50	2SC364	1.15	2SC784	.70	2SC1243	1.50	2SD170	2.00
2SA628	.65	2SC372	.70	2SC785	1.00	2SC1293	.85	2SD180	2.75
2SA643	.85	2SC394	.70	2SC789	.95	2SC1306	4.75	2SD201	1.95
2SA647	2.75	2SC458	.70	2SC793	2.50	2SC1307	5.75	2SD218	4.75
2SA673	.85	2SC460	.70	2SC796	3.15	2SC1308	4.75	2SD235	1.00
2SA679	3.75	2SC478	.80	2SC797	2.50	2SC1317	.60	2SD300	2.50
2SA682	.85	2SC481	1.85	2SC798	3.10	2SC1318	.70	2SD313	1.10
2SA699	1.30	2SC482	1.75	2SC799	4.25	2SC1325	4.95	2SD315	.75
2SA699A	1.45	2SC491	2.50	2SC802	3.75	2SC1327	.70	2SD316	2.50
2SA705	.55	2SC495	1.10	2SC803	4.00	2SC1338	1.75	2SD317	.95
2SA715	.85	2SC497	1.60	2SC815	.75	2SC1346	.80	2SD318	1.25
2SA816	.85	2SC502	1.50	2SC828	.75	2SC1347	.80	2SD325	1.25
		2SC515	.80	2SC829	.75	2SC1364	1.50	2SD341	.95
		2SC517	4.25	2SC830	1.60	2SC1377	5.50	2SD350	3.25
		2SC535	.75	2SC838	.70	2SC1383	.75	2SD352	.80
		2SC536	.65	2SC839	.85	2SC1384	.85	2SD380	.70
		2SC537	.70	2SC922	.55	2SC1409	1.25	2SD389	5.75
		2SC563	2.50	2SC929	.70	2SC1410	1.25	2SD390	.75
		2SC607	1.25	2SC930	.65	2SC1447	1.25		
		2SC614	3.80	2SC938	.65	2SC1448	1.25	2SF8	3.00
		2SC615	3.90	2SC943	1.50	2SC14			

Radio Hut

Money back guarantee. NO COD'S. Texas residents add 5% sales tax. Add 5% of order for postage and handling. Orders under \$15.00 add 75 cents. Foreign orders add 10% for postage.

For your convenience, call your BankAmericard or Master Charge orders in on our Toll Free Watts Line: 1-800-527-2304. Texas residents call collect: 1-214-271-8423.



P. O. Box 38323P
Dallas, Texas 75238



Memorex computer boards with IC's, diodes, transistor, etc. 5 Boards containing 100 - 200 IC's
ONLY \$ 4.25

BRIDGE RECTIFIERS

6 Amp	50V	1.10
10 Amp	50V	1.25
25 Amp	50V	1.39

RESISTORS

Over 50,000,000 in stock

*330 ohm	22K ohm
470 ohm	27K ohm
**680 ohm	33K ohm
1K ohm	39K ohm
1.2K ohm	43K ohm
2.2K ohm	47K ohm
3.3K ohm	82K ohm
4.7K ohm	100K ohm
6.8K ohm	150K ohm
10K ohm	220K ohm
20K ohm	

*1/8 W only
**1/2 W only

All resistors are P.C. Lead but are not pull offs.

100 min. order for each value

NO MIX 100/99

MK 5005

4 digit counter/latch decoder; 7 segment output only. 24 pin dip with specs.

\$ 8.00 EACH

UNSCRAMBLER KIT for all Scanners

- Tunes easily
 - Full instructions included
 - Easy to install
 - 3 1/2" x 3 1/2" x 1 1/2"
- Only \$19.95**

PLASMA DISPLAY KIT

Kit Includes: 12 digit display .4" Character Power supply for display above Complete specs for hookup.

Line cord Not Included. **ONLY \$ 3.95**



SPECIAL DEVICES

82S23	2.19
2513	10.00
2102-1	.99
1101A	.75
1103A	1.10
8T13	1.50
8T97	1.25
MM5233	1.50
300KC xtal	1.50

REGULATORS

7805	7818
7806	7824
7808	7905
7812	7912
7815	7915

Your Choice \$.95

READOUTS



FND70 .4"C.C.	.59
FND800 .8"C.C.	1.69
TI 6 digit array C.C.	3/1.00
MAN 8 .3"CA Yellow	.89
LT767 .7" C.C. 4 digit stick	\$ 3.95

WATERGATE SPECIAL

Telephone Relay automatically starts and stops tape recorder. No batteries required. Kit complete with drilled P.C. Board.

Parts and Case **ONLY \$10.95**

VARIABLE POWER SUPPLY KIT NO. 1

- *Continuously variable from 5V to 20V
 - *Excellent regulation up to 500 mil.
 - *4400 Mfd of filtering
 - *Drilled fiberglass PC Board
 - *One hour assembly
 - *Kit includes all components
 - *Case Included
- ONLY \$10.95**

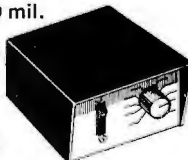

VARIABLE POWER SUPPLY KIT NO. 2

Same as above but with 1 amp output, also with case. **ONLY \$13.95**

CLOCK KIT

Kit includes

- LT701 clock module
- Power Supply
- Punched Case
- 12 hour operation only



Complete except for line cord

ONLY \$ 14.95 LT701E 12 hour clock
LT701G 24 hour clock

BATTERY CLIPS

Standard 9V battery clip with 4-1/2" tinned leads. **25/\$1.00**

TRANSISTORS - DIODES

*MJE1103	3/1.00
MJ3001	1.30
2N2222	6/1.00
2N2369	6/1.00
2N2905	4/1.00
*2N2907	15/1.00
2N3906	6/1.00
2N4400	6/1.00
2N4443 SCR	3/1.00
1N4004	15/1.00
1N4007	10/1.00
1N4148 (1N914)	20/1.00
3N201 VHF Pre amp	.80
D40C1 Power Darl - 8/1.00	.20
EN930	.20
IN746	.25

*House numbered and P.C. Lead

PC BOARDS

4 digit PCB for FND800 or 807	2.50
6 digit PCB for FND800 or 807	3.50
4 digit PCB for DL707	1.50
6 digit PCB for DL707	2.00
4 digit PCB for FND503 or 510	2.00
6 digit PCB for FND503 or 510	3.00
4 digit PCB for DL747	2.50
6 digit PCB for DL747	3.00
4 digit PCB for DL727 or 728	2.00
6 digit PCB for DL727 or 728	3.00
4 digit PCB for FND359 or 70	1.75

NOTE: All PC Boards are multiplexed for adding additional digits.

SOCKETS

14 pin	.22
16 pin	.25
18 pin	.25
24 pin (ww only)	.95
28 pin	.35
40 pin	.50

CMOS SALE

CD4000	.16	CD4011	.16
CD4001	.16	CD4012	.16
CD4002	.16	CD4013	.16
CD4007	.16	CD4014	.16
CD4009	.45	CD4015	.16
CD4010	.45	CD4016	.29
CD4011	.16	CD4017	.80
CD4012	.16	CD4018	.80
CD4013	.16	CD4019	.39
CD4014	.16	CD4020	.85
CD4015	.16	CD4021	.90
CD4016	.29	CD4022	.90
CD4017	.80	CD4024	.70
CD4018	.80	CD4025	.19
CD4019	.39	CD4027	.39
CD4020	.85	CD4028	.75
CD4021	.90	CD4029	.99
CD4022	.90	CD4030	.16
CD4024	.70	CD4034	2.30
CD4025	.19	CD4035	.90
CD4027	.39	CD4036	.90
CD4028	.75	CD4040	1.00
CD4029	.99	CD4041	.69
CD4030	.16	CD4042	.59
CD4034	2.30	CD4043	.60
CD4035	.90	CD4044	.59
CD4036	.90	CD4046	.90
CD4040	1.00	CD4047	.59
CD4041	.69	CD4049	.35
CD4042	.59	CD4050	.35
CD4043	.60	CD4051	.90
CD4044	.59	CD4053	.90
CD4046	.90	CD4056	1.00
CD4047	.59	CD4058	.90
CD4049	.35	CD4060	1.00
CD4050	.35	CD4065	.69
CD4051	.90	CD4069	.30
CD4053	.90	CD4071	.16
CD4056	1.00	CD4076	.99
CD4058	.90	74C04	.29
CD4060	1.00	74C107	.29
CD4065	.69	CD4115	.39
CD4069	.30	CD4507	.40
CD4071	.16	CD4512	.50
CD4076	.99	CD4516	.85
74C04	.29	CD4518	.85
74C107	.29	CD4520	.85
CD4115	.39		
CD4507	.40		
CD4512	.50		
CD4516	.85		
CD4518	.85		
CD4520	.85		

LS

74LS00	.26	74LS145	1.00
74LS02	.26	74LS151	.70
74LS03	.26	74LS153	.70
74LS04	.30	74LS155	.69
74LS05	.32	74LS156	.76
74LS08	.26	74LS157	.95
74LS09	.26	74LS158	.85
74LS10	.26	74LS160	.85
74LS11	.35	74LS161	.85
74LS13	.58	74LS162	.85
74LS14	1.05	74LS163	.85
74LS15	.26	74LS168	.85
74LS20	.24	74LS169	.85
74LS21	.35	74LS170	2.00
74LS22	.35	74LS173	1.10
74LS26	.35	74LS174	1.00
74LS27	.34	74LS175	1.00
74LS30	.34	74LS190	.95
74LS32	.35	74LS191	.95
74LS37	.33	74LS192	.95
74LS38	.38	74LS193	.95
74LS40	.34	74LS194	.95
74LS42	.80	74LS195	.95
74LS51	.26	74LS196	.85
74LS54	.26	74LS197	.85
74LS55	.26	74LS201	.85
74LS73	.75	74LS203	.85
74LS74	.49	74LS207	.85
74LS76	.49	74LS258	.85
74LS86	.45	74LS260	.26
74LS90	.85	74LS266	.26
74LS92	1.00	74LS279	.55
74LS93	1.00	74LS290	.75
74LS109	.49	74LS293	.75
74LS112	.49	74LS295	.95
74LS113	.40	74LS298	.95
74LS114	.40	74LS365	.55
74LS125	.55	74LS366	.55
74LS126	.65	74LS367	.55
74LS132	1.00	74LS368	.55
74LS133	.35	74LS390	1.75
74LS136	.39	74LS393	1.45
74LS138	.85	74LS670	3.25
74LS139	.85		

ORDER BY PHONE. Charge your

order to BankAmericard or Master Charge.

USE OUR TOLL FREE WATTS

1-800-527-2304

60 Hz L(●)(●)K

Crystal Time Base Kit - Kit

enables a MOS clock circuit to operate from a DC power source. Ideal for car, camper, van, boat, etc.

60Hz output with an accuracy of .005% (typ.) Low power consumption 2.5 ma (typ.). Small size will fit most any enclosure. Single MOS IC oscillator/divider chip 5-15 volts DC operation.

ONLY \$ 5.95
2 for \$10.00

NOW! For the Dallas Area Residents.

Come Visit Our Retail Store.
3717 Lincoln Court, Garland, Texas
Tues. - Fri. 10 AM to 6 PM
Sat. 10 AM to 3 PM
CLOSED MONDAY

SPECIAL FIVE ★ STAR EDITION

★ Check the Stars for Special Values ★

Still the Biggest, Brightest, "Bestest" 5" LED, 6 DIGIT AC/DC ALARM CLOCK KIT & ELAPSED TIMER \$19.95 Complete

- PC Board Drilled & Silk Screened (Includes Xtal Time Base Circuitry)
- 5375 Nat. Clock Chip & Fairchild Displays
- Includes EVERY part required for clock and all options except Cabinet and Crystal Time Base components. If desired, see below.
- Brightness Control
- Freeze feat. on every mode
- Field Tested over 1 Yr.
- 24 Hr. Alarm w/snooze
- 0-60 Min. Elapsed Timer
- 12 Hr., 60 Hz oper.

Most Important — Complete Instructions, schematics Pictorials, layouts — everything for trouble free assembly
OPTIONS — XTAL Time Base Components - \$2.95 when purchased w/clock Wood Clock Cabinet (A) — \$4.00

WOODEN CLOCK CABINETS

Includes: Filter & Back
Walnut Grain or
Black Leatherette (A only)
\$5.00 ea.

Dimensions (Inside)
A — 1-13/16"H, 5 1/2"W, 4 3/4"D
B — 1 7/8"H, 4 3/4"W, 4 3/4"D
Extra Filters — Red, Smoke
Blue, Amber, & Green — \$.60

AC/DC - ALARM Clock Kit - 12/24 Hr.

\$7.50 quantities of 1-5 \$6.50 quantities of 6 & up

- Displays Hrs. & Min. - Switch to Min. & Secs. on Command.
 - AM/PM Indication
 - Field Tested for 6 months
- The kit will include a 5316 National Clock Chip, 4 Fluorescent Display tubes, all electronic components, switches, controls & complete instructions, specs, etc. for clock and all optional Features. Other parts required or if desired are as follows:

- PC Board, Drilled — \$3.00
- Xformer (for AC oper.) — \$1.00
- Speaker Alarm Kit — \$2.00
- Plexiglas Case (Kit) — \$2.00 w/purchase of clock

CLOCK CHIPS

MMS314	\$3.50
MMS316	3.50
MMS387 (Hi Cur. 5316)	3.95
MMS375	3.95
CT7001	7.95
CT7010	6.95

IC SOCKETS

8,14,16,18 Pin	5 for 1.00
24 Pin & 28 Pin	3 for 1.00
40 Pin	2 for 1.00

TRANSFORMERS

Plug type-12VAC 250MA	2.50
PC Mnt.-12VAC 250MA	1.50
Bkt Mnt.-SVAC 6 Amp	4.95

DIODES

IN4001-IN4007 Mix	50 for 4.00
IN914 or IN4148	20 for 1.00
2.5 Amp 1000 Volts	5 for 1.00

★ MA1003 MOBIL CLOCK MODULE ★ (National) \$21.95

Flourescent Display gives Color Choice
(Red, Blue, Green or Yellow)
when used w/corresponding Color Filter
Includes — Module, Switches, Filter & Specs

7 SEG LED DISPLAYS

.33" Type 707/MAN-1 14 Pin Dip
Common Anode or Cathode
\$.59 ea. 10 for \$5.00

★ ADJUSTABLE AC VARIABLE VOLTAGE CONTROLLER ★ \$4.95 ea.

110 Volt — 10 Amps

USES — Motor Controller, Dimmers, Any Variable AC Voltage Application

60 HZ. CRYSTAL TIME BASE KIT \$4.95

Use with Digital Clocks
for 12VDC or Portable Operation
KIT INCLUDES:
PC Board, 5369 Divider Chip
3.5795 MHZ XTAL &
All Other Parts
Complete Instructions

★ 6 Digit LED Stop-Watch Kit ★ Split Time \$29.95 complete Taylor Time

FEATURES: Reads minutes, seconds, & 100ths of seconds
6 bright easily readable digits
Needs only 9 volt Xistor battery

KIT INCLUDES: • HAND HELD CASE DESIGNED FOR ABOVE
• Latest Technology Intersil Mos Chip # 7205
• 3.2768 MHZ Crystal • Variable Trimmer Cap
• 2 mini slide & 3 MOM. PB Switches
• 3 pairs (6) digits) Double Digit LED Displays
P.C. BOARD for above and all components

Voltage Regulators

Positive-To 220 Pkg.	Negative-To 220 Pkg.
7805	\$1.00
7806	1.00
7812	1.00
7815	1.00
7824	1.00
LM309K	1.25

LED'S

Jumbo Red LED's	10 for 1.00 100 for 9.00
25 Pk. LED's Asstd. Sizes & Colors	2.50
Bi-Polar LED Red/Green	1.00

Transistors

2N2222A	4/1.00
2N3904 type NPN	8/1.00
2N3906 type PNP	8/1.00
2N3055 (NPN,T0-3)	.75
2N4904 (PNP,T0-3)	.85

Bridges

1 1/2 Amp 200 volt	3/1.00
6 Amp 600 volt	3/2.00
25 Amp 200 volt	3/5.00

Prescalars

95H90	8.95
11C90	14.95

THE BIG ONE .8" LED Alarm Clock Kit

simple construction



\$17.95 Complete

Includes:
Power Supply, Speaker,
IC Socket
PC Board, Clock Chip, Switches
Fairchild .8" Display Module,
xistors, resistors, capacitors,
Complete Instructions

Features:
• Hrs. & Min. Switch to Min. & Sec. on Command
• 12 Hr. - 24 Hr. Alarm
• 10 Min. Snooze
• AM/PM Indicators
• Sleep Output

OPTION — Wood Clock Cabinet (B) — \$4.00 w/purchase of clock

Dual Range DIGITAL Voltmeter Kit \$39.95 Complete 0 to ±.2 Volts DC — 0 to ±2 Volts DC

- Features latest Technology DVM chip set
- Non Critical Comp.
- High Noise Rejection
- Accuracy to within .001

Contains — P.C. Boards; 4-large .50 Fairchild Readouts; Display Drivers; Op-Amps; Inverter; all electronic comp; Switches, Pots; Complete Instructions and Specs; & DVM Chip Set.

Requirements: Power Supply w/+5V, +15V and -15V.
OPTIONS — Set/Precision Resistors for Increasing Voltage Range up to 200 Volts — \$2.95

NOTE — Complete Specs, Schem. etc., for Multi-Meter

The SUPER COMPACT \$13.95 Complete

Includes: All Parts, PC Board
Power Supply & Case
Colors: Black, Silver, or Gold
Size: 4.75" x 1.8" x 1.4"
Material: Extruded Alum.



OPTION — Temperature Ind. Front Panel — \$3.00

Features:
4-large .4" LED Displays
12/24 hour Format

BankAmericard-Master Charge Minimum \$10.00 on Charge Call Your Order In For Immediate Shipment 201-755-0590 Effective after Sept. 11th

Hrs.: Mon. thru Friday - 9:00 A.M. to 6:00 P.M.
Tues. & Thursday - 7:00 P.M. to 10:00 P.M.

Terms & Conditions: Orders must incl. Ck. - No COD's - Add \$1.00 handling for orders under \$25.00 - Outside Cont. USA add Total Postage - 10% Air Mail - N.J. resid. add 5% Tax

6 DIGIT LED MOBILE Clock Kit & Elapsed Timer

.4" Digits 12 or 24 Hr.
Quartz Crystal Controlled
12 Volt DC or AC operation

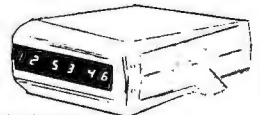

\$27.95 Complete
(less 9V battery)

- Protection from noise & High Impulses
- Display Blanking Capability
- Battery Back-Up Capability
- Size 4" x 1 3/4" x 4 1/2"
- Rugged High Impact ABS
- Recessed Front Switches

OPTION — AC Adaptor \$2.50

HOBB-Y-TRONIX, INC.

351 Rahway Road, Edison, N.J. 08817
Phone: 201-755-0590 — Phone effective 9/12/77



FREE INFORMATION:

Learning more about a product that's advertised or mentioned in an article in this month's issue is as simple as one, two, three. And absolutely free.

1 Print or type your name and address on the attached card. Use only one card per person.

2 Circle the number(s) on the card that correspond to the number(s) at the bottom of the advertisement or article for which you want more information. (Key numbers for advertised products also appear in the Advertisers' Index.)

3 Simply mail the card, and the literature will be mailed to you free of charge from the manufacturer.

FREE INFORMATION:

This address is for our product Free Information Service only. Editorial inquiries should be directed to POPULAR ELECTRONICS, One Park Avenue, New York, N.Y. 10016.

POPULAR ELECTRONICS

USE ONLY ONE CARD PER PERSON

PE9773

NAME _____

ADDRESS _____

CITY _____

STATE _____

ZIP _____

(Zip Code must be included to insure delivery.) (Void after Nov. 30, 1977)

Do you own any of the following?

- a. Digital VOM b. Multimeter c. Function Generator
d. Oscilloscope e. Frequency Counter
f. Transistor Tester g. Microcomputer H. None of the above

Please send me 12 issues of Popular Electronics for \$6.99 and bill me.

1 2 3 4 5 6 7 8 9 10 11 12 13 14 15
16 17 18 19 20 21 22 23 24 25 26 27 28 29 30
31 32 33 34 35 36 37 38 39 40 41 42 43 44 45
46 47 48 49 50 51 52 53 54 55 56 57 58 59 60
61 62 63 64 65 66 67 68 69 70 71 72 73 74 75
76 77 78 79 80 81 82 83 84 85 86 87 88 89 90
91 92 93 94 95 96 97 98 99 100 101 102 103 104 105
106 107 108 109 110 111 112 113 114 115 116 117 118 119 120

POPULAR ELECTRONICS

USE ONLY ONE CARD PER PERSON

PE9772

NAME _____

ADDRESS _____

CITY _____

STATE _____

ZIP _____

(Zip Code must be included to insure delivery.) (Void after Nov. 30, 1977)

Do you own any of the following?

- a. Digital VOM b. Multimeter c. Function Generator
d. Oscilloscope e. Frequency Counter
f. Transistor Tester g. Microcomputer H. None of the above

Please send me 12 issues of Popular Electronics for \$6.99 and bill me.

1 2 3 4 5 6 7 8 9 10 11 12 13 14 15
16 17 18 19 20 21 22 23 24 25 26 27 28 29 30
31 32 33 34 35 36 37 38 39 40 41 42 43 44 45
46 47 48 49 50 51 52 53 54 55 56 57 58 59 60
61 62 63 64 65 66 67 68 69 70 71 72 73 74 75
76 77 78 79 80 81 82 83 84 85 86 87 88 89 90
91 92 93 94 95 96 97 98 99 100 101 102 103 104 105
106 107 108 109 110 111 112 113 114 115 116 117 118 119 120

POPULAR ELECTRONICS

USE ONLY ONE CARD PER PERSON

PE9771

NAME _____

ADDRESS _____

CITY _____

STATE _____

ZIP _____

(Zip Code must be included to insure delivery.) (Void after Nov. 30, 1977)

Do you own any of the following?

- a. Digital VOM b. Multimeter c. Function Generator
d. Oscilloscope e. Frequency Counter
f. Transistor Tester g. Microcomputer H. None of the above

Please send me 12 issues of Popular Electronics for \$6.99 and bill me.

1 2 3 4 5 6 7 8 9 10 11 12 13 14 15
16 17 18 19 20 21 22 23 24 25 26 27 28 29 30
31 32 33 34 35 36 37 38 39 40 41 42 43 44 45
46 47 48 49 50 51 52 53 54 55 56 57 58 59 60
61 62 63 64 65 66 67 68 69 70 71 72 73 74 75
76 77 78 79 80 81 82 83 84 85 86 87 88 89 90
91 92 93 94 95 96 97 98 99 100 101 102 103 104 105
106 107 108 109 110 111 112 113 114 115 116 117 118 119 120

First Class
Permit No. 217
Clinton, Iowa

BUSINESS REPLY MAIL

No postage necessary if mailed in the United States

POSTAGE WILL BE PAID BY

Popular Electronics

P.O. Box 2905
Clinton, Iowa 52732

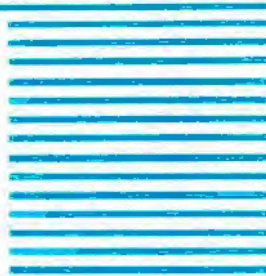

First Class
Permit No. 217
Clinton, Iowa

BUSINESS REPLY MAIL

No postage necessary if mailed in the United States

POSTAGE WILL BE PAID BY

Popular Electronics

P.O. Box 2905
Clinton, Iowa 52732



First Class
Permit No. 217
Clinton, Iowa

BUSINESS REPLY MAIL

No postage necessary if mailed in the United States

POSTAGE WILL BE PAID BY

Popular Electronics

P.O. Box 2905
Clinton, Iowa 52732



Stereo Review is proud
to announce an
important set of
recordings created
to help you expand your
understanding of music.

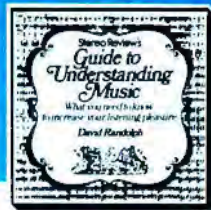

This unique four-disc album is interesting, easy to comprehend, and instructive. It is the first project of its kind to approach the understanding of music through its basic elements: rhythm . . . melody . . . harmony . . . texture.

Written and narrated exclusively for Stereo Review by David Randolph, Music Director of the Masterwork Music and Art Foundation, this fascinating set of stereo records will help you become a more sophisticated, more knowledgeable listener.

In the GUIDE TO UNDERSTANDING MUSIC, David Randolph first discusses, by means of recorded narration, how the composer uses and unifies all the basic musical elements. After each musical point is made in the narration, a musical demonstration of the point under discussion is provided. Thus you become a part of the creative musical process by listening, by understanding, by seeing how music's "raw materials" are employed by composers and performers to attain their highest level of expressivity and communication through musical form.

FOUR LONG-PLAY STEREO RECORDS:

Record I—The Elements of Music. 1. Rhythm, 2. Melody, 3. Harmony, 4. Texture.

Record II—Sense and Sensation in Music. (The Instruments of the Orchestra.) How Music is Unified.

Record III—Form in Music. Words and music.

Record IV—Can Music Tell a Story or Paint a Picture? The Interpretation of Music.

The GUIDE TO UNDERSTANDING MUSIC contains OVER 200 MUSICAL EXAMPLES which have been carefully chosen from among thousands of recordings by major record companies as the best illustrations of musical points made in the recorded narration.

FREE BOOKLET INCLUDED. The accompanying booklet is a valuable complement to the album. It presents David Randolph's straightforward professional approach to music . . . as well as advice on how you can make the best use of the album.

The exclusive four-disc recording is available from Stereo Review. The special low price is just \$21.98, postpaid, for all four 33 1/2 rpm stereo long-play records.

HERE'S HOW TO ORDER

CASH: Mail your order along with your name, address and remittance in the amount of \$21.98. Residents of CA, CO, FL, IL, MI, MO, NY STATE, DC and TX add applicable sales tax.

CHARGE: To your American Express, BankAmericard, Master Charge or Diners Club account! Mail your order, name, address, credit card # and expiration date (Master Charge customers include 4-digit Interbank # above your name). Be sure your signature is on your order. You will be billed at \$21.98.

OUTSIDE U.S.A. ALBUM IS \$26.98.

ORDER FROM: GUM, CONSUMER SERVICE DIVISION, 595 BROADWAY, NEW YORK, N.Y. 10012.

Watch for our supermarket bargains each month!

any way you look at it

POLY PAKS® IS THE WORLD'S LARGEST ELECTRONIC DISCOUNT SUPERMARKET
SEP. 77 POP ELECTRONICS SPECIALS

—FEATURING THE BARGAINS OF THE MONTH!!!—

\$5.50 TV GAME JOY STICK
Includes four 100K pots
For TV & computer games, and quadrophonic balancing. 1/2 x 1 1/2 x 1 1/2". With 1" handle. Wt. 6 oz. Cat. No. 9E3808

RCA High quality "POCKET" VOM
1000 ohms per volt
Model WV-539A. Features 1% precision, movement, diode protected against burnout. Measures DC volts 0-15-150-1000; AC volts 0-15-150-1000; DC current 0-150ma; resistance X1000. Sensitivity 1000 ohms/volt AC-DC. Uses penlite cell, not included. Size 2 3/4 x 3 1/4 x 1 3/4". Wt. 5.2 oz. Cat. No. 9E3921

\$8.88

SPECIAL THIS AD G-E "BLUE" FLUORESCENT READOUTS
Bright blue 7-segment characters, 0.57" high! 1.5V filament, 24V characters. Common cathode. Fits standard 9-pin tube socket. Driven directly by MM5311. Wt. 3 oz. Cat. No. 9R3694

\$1.00 each
MM5316 Clock Chip — \$2.95
Cat. No. 9E1759

6-DIGIT CAR CLOCK KIT
For auto, plane, boat, van, etc. Top quality & accuracy at the lowest price! Displays hours, minutes & seconds in 12 hour format. Controls for fast & slow set. Attractive grey cabinet with chrome trimmed red lens. Only 4 1/2 x 4 1/2 x 1 1/2". Complete "Clock Kit", 12 VDC. Wt. 14 ozs.

\$2200
REG. \$26.88

Cat. No. 9E3852

- Crystal controlled time base!
- Easy to assemble and install!
- Bright RED 0.35" LED digits!

\$12.95 J. C. PENNEY'S 8-Track TAPE TRANSPORT
Excellent replacement of design in your own quality tape system! Automatic or manual track selection with program indicator lights. Player shuts off automatically when tape is removed. Built-in low-distortion preamp and wow free motor. With input & output cables. Requires external power supply. With instruction manual. Size 5 1/2 x 6 3/4 x 2 1/2". Wt. 4 lbs. Cat. No. 9E3010

- 115 VAC fan-cooled motor
- Slides easily into modular cabinet
- Shielded preamp

SPECTROL "SKINNY-TRIMS" 3/8" Sq. POTENTIOMETERS
Choose ANY 3 FOR **\$1.19**
3/8" square. Screwdriver shaft, 20% tolerance, 1/2 watt. Cermet construction, PC leads. Order by Cat. No. and Value.

OHMS	Code
10	1K
20	2K
50	5K
100	10K
200	20K
500	50K
1K	100K
2K	200K
5K	500K
10K	1M
20K	2M
50K	5M
100K	10M
200K	20M
500K	50M
1M	100M
2M	200M
5M	500M
10M	1M
20M	2M
50M	5M
100M	10M
200M	20M
500M	50M
1M	100M
2M	200M
5M	500M
10M	1M
20M	2M
50M	5M
100M	10M
200M	20M
500M	50M
1M	100M
2M	200M
5M	500M
10M	1M
20M	2M
50M	5M
100M	10M
200M	20M
500M	50M
1M	100M
2M	200M
5M	500M
10M	1M
20M	2M
50M	5M
100M	10M
200M	20M
500M	50M
1M	100M
2M	200M
5M	500M
10M	1M
20M	2M
50M	5M
100M	10M
200M	20M
500M	50M
1M	100M
2M	200M
5M	500M
10M	1M
20M	2M
50M	5M
100M	10M
200M	20M
500M	50M
1M	100M
2M	200M
5M	500M
10M	1M
20M	2M
50M	5M
100M	10M
200M	20M
500M	50M
1M	100M
2M	200M
5M	500M
10M	1M
20M	2M
50M	5M
100M	10M
200M	20M
500M	50M
1M	100M
2M	200M
5M	500M
10M	1M
20M	2M
50M	5M
100M	10M
200M	20M
500M	50M
1M	100M
2M	200M
5M	500M
10M	1M
20M	2M
50M	5M
100M	10M
200M	20M
500M	50M
1M	100M
2M	200M
5M	500M
10M	1M
20M	2M
50M	5M
100M	10M
200M	20M
500M	50M
1M	100M
2M	200M
5M	500M
10M	1M
20M	2M
50M	5M
100M	10M
200M	20M
500M	50M
1M	100M
2M	200M
5M	500M
10M	1M
20M	2M
50M	5M
100M	10M
200M	20M
500M	50M
1M	100M
2M	200M
5M	500M
10M	1M
20M	2M
50M	5M
100M	10M
200M	20M
500M	50M
1M	100M
2M	200M
5M	500M
10M	1M
20M	2M
50M	5M
100M	10M
200M	20M
500M	50M
1M	100M
2M	200M
5M	500M
10M	1M
20M	2M
50M	5M
100M	10M
200M	20M
500M	50M
1M	100M
2M	200M
5M	500M
10M	1M
20M	2M
50M	5M
100M	10M
200M	20M
500M	50M
1M	100M
2M	200M
5M	500M
10M	1M
20M	2M
50M	5M
100M	10M
200M	20M
500M	50M
1M	100M
2M	200M
5M	500M
10M	1M
20M	2M
50M	5M
100M	10M
200M	20M
500M	50M
1M	100M
2M	200M
5M	500M
10M	1M
20M	2M
50M	5M
100M	10M
200M	20M
500M	50M
1M	100M
2M	200M
5M	500M
10M	1M
20M	2M
50M	5M
100M	10M
200M	20M
500M	50M
1M	100M
2M	200M
5M	500M
10M	1M
20M	2M
50M	5M
100M	10M
200M	20M
500M	50M
1M	100M
2M	200M
5M	500M
10M	1M
20M	2M
50M	5M
100M	10M
200M	20M
500M	50M
1M	100M
2M	200M
5M	500M
10M	1M
20M	2M
50M	5M
100M	10M
200M	20M
500M	50M
1M	100M
2M	200M
5M	500M
10M	1M
20M	2M
50M	5M
100M	10M
200M	20M
500M	50M
1M	100M
2M	200M
5M	500M
10M	1M
20M	2M
50M	5M
100M	10M
200M	20M
500M	50M
1M	100M
2M	200M
5M	500M
10M	1M
20M	2M
50M	5M
100M	10M
200M	20M
500M	50M
1M	100M
2M	200M
5M	500M
10M	1M
20M	2M
50M	5M
100M	10M
200M	20M
500M	50M
1M	100M
2M	200M
5M	500M
10M	1M
20M	2M
50M	5M
100M	10M
200M	20M
500M	50M
1M	100M
2M	200M
5M	500M
10M	1M
20M	2M
50M	5M
100M	10M
200M	20M
500M	50M
1M	100M
2M	200M
5M	500M
10M	1M
20M	2M
50M	5M
100M	10M
200M	20M
500M	50M
1M	100M
2M	200M
5M	500M
10M	1M
20M	2M
50M	5M
100M	10M
200M	20M
500M	50M
1M	100M
2M	200M
5M	500M
10M	1M
20M	2M
50M	5M
100M	10M
200M	20M
500M	50M
1M	100M
2M	200M
5M	500M
10M	1M
20M	2M
50M	5M
100M	10M
200M	20M
500M	50M
1M	100M
2M	200M
5M	500M
10M	1M
20M	2M
50M	5M
100M	10M
200M	20M
500M	50M
1M	100M
2M	200M
5M	500M
10M	1M
20M	2M
50M	5M
100M	10M
200M	20M
500M	50M
1M	100M
2M	200M
5M	500M
10M	1M
20M	2M
50M	5M
100M	10M
200M	20M
500M	50M
1M	100M
2M	200M
5M	500M
10M	1M
20M	2M
50M	5M
100M	10M
200M	20M
500M	50M
1M	100M
2M	200M
5M	500M
10M	1M
20M	2M
50M	5M
100M	10M
200M	20M
500M	50M
1M	100M
2M	200M
5M	500M
10M	1M
20M	2M
50M	5M
100M	10M
200M	20M
500M	50M
1M	100M
2M	200M
5M	500M
10M	1M
20M	2M
50M	5M
100M	10M
200M	20M
500M	50M
1M	100M
2M	200M
5M	500M
10M	1M
20M	2M
50M	5M
100M	10M
200M	20M
500M	50M
1M	100M
2M	200M
5M	500M
10M	1M
20M	2M
50M	5M
100M	10M
200M	20M
500M	50M
1M	100M
2M	200M
5M	500M
10M	1M
20M	2M
50M	5M
100M	10M
200M	20M
500M	50M
1M	100M
2M	200M
5M	500M
10M	1M
20M	2M
50M	5M
100M	10M
200M	20M
500M	50M
1M	100M
2M	200M
5M	500M
10M	1M
20M	2M
50M	5M
100M	10M
200M	20M
500M	50M
1M	100M
2M	200M
5M	500M
10M	1M
20M	2M
50M	5M
100M	10M
200M	20M
500M	50M
1M	100M
2M	200M
5M	500M
10M	1M
20M	2M
50M	5M
100M	10M
200M	20M
500M	50M
1M	100M
2M	200M
5M	500M
10M	1M
20M	2M
50M	5M
100M	10M
200M	20M
500M	50M
1M	100M
2M	200M
5M	500M
10M	1M
20M	2M
50M	5M
100M	10M
200M	20M
500M	50M
1M	100M
2M	200M
5M	500M
10M	1M
20M	2M
50M	5M
100M	10M
200M	20M
500M	50M
1M	100M
2M	200M
5M	500M
10M	1M
20M	2M
50M	5M
100M	10M
200M	20M
500M	50M
1M	100M
2M	200M
5M	500M
10M	1M
20M	2M
50M	5M
100M	10M
200M	20M
500M	50M
1M	100M
2M	200M
5M	500M
10M	1M
20M	2M
50M	5M
100M	10M
200M	20M
500M	50M
1M	100M
2M	200M
5M	500M
10M	1M
20M	2M
50M	5M
100M	10M
200M	20M
500M	50M
1M	100M
2M	200M
5M	500M
10M	1M
20M	2M
50M	5M
100M	10M
200M	20M
500M	50M
1M	100M
2M	200M
5M	500M
10M	1M
20M	2M
50M	5M
100M	10M
200M	20M

S.D. SALES CO. P.O. BOX 28810 - D DALLAS, TEXAS 75228

★ Imsai - Altair "A" Compatible Kits ★

Z-80 CPU KIT COMPLETE - \$149. kit

Z-80 Chip & Manual \$49.95

Z-80 Manual - \$7.50 Separately

From the same people who brought you the \$89.95 4K RAM KIT. We were not the first to introduce an Imsai/Altair compatible Z-80 Card, but we do feel that ours has the best design and quality for the lowest price!
 The advance features of the Z-80 such as an expanded set of 158 instructions, 8080A software compatibility, and operation from a single 5VDC supply, are all well known. What makes our card different is the extra care we took in the hardware design. The CPU card will always stop on an M1 state. We also generate TRUE SYNC on card, to insure that the rest of your system functions properly. Dynamic memory refresh and NMI are brought out for your use. Believe it or not, not all of our competitors have gone to the extra trouble of doing this.
 As always this kit includes all parts, all sockets, and complete instructions for ease of assembly. Because of our past experience with our 4K kit we suggest that you order early. All orders will be shipped on a strict first come first served basis. Dealers inquiries welcome on this item. Kit includes Zilog Manual and all parts. Kit shipped with 2 MHz crystals.

THE WHOLE WORKS
\$89.95

4K LOW POWER RAM BOARD KIT

Imsai and Altair 8080 plug in compatible. Uses low power static 21L02-1 500 ns. RAM'S. Fully buffered, drastically reduced power consumption, on board regulated, all sockets and parts included. Premium quality plated through PC Board.
For 250 ns RAM's add \$10.00

NEW! DESIGN CONSOLETTA KIT - \$89.95

S.D. Sales announces the inexpensive way to beat the wire wrap jungle. Our latest kit gives you 124 solderless quick connect terminals, enough for eight 16 pin IC's and provides 50 x 8 common buss matrix. Has regulated +5VDC and +/- 15VDC, all at 1 AMP. Voltage regulation at 100%. Also includes a pulse generator variable from 10hz to 50mhz and .01 sec. to 100 nano seconds. Generator output is +5V. In kit form only and includes all parts, sockets; front panel measures 7 1/4" x 8 1/4", and hardware. case not available.

CAR/BOAT KIT
\$34.95

Music to your Ears!

New Item!

MUSICAL HORN

Musical Horn Kit for car, boat, or home. Plays any tune from Mozart to Led Zepplin. Change tunes in seconds; complete solid state electronics. Standard or custom tunes available at \$6.95 each (you supply us with the sheet music - we supply electronics for your favorite tune.) One song supplied with original order. Standard tunes available: DIXIE - EYES OF TEXAS - ON WISCONSIN - YANKEE DOODLE DANDY - NOTRE DAME FIGHT SONG - PINK PANTHER - AGGIE WAR SONG - ANCHORS AWAY - NEVER ON SUNDAY - BRIDGE OVER RIVER OUI - CANDY MAN.

HOME KIT
\$26.90

Home kit includes speaker which operates from your door bell. When door bell is pushed your favorite tune is played. Car/boat kit DOES NOT include speaker. Uses standard Bohm PM speaker. Allow 4 weeks delivery on both kits.

Limited Quantity!
\$9.95 kit

6 DIGIT ALARM CLOCK KIT

We made a fantastic kit even better. Redesigned to take advantage of the latest advances in IC technology. Features: Litronix Dual 1/2" displays, Mostek 50250 super clock chip, single I.C. segment driver, SCR digit drivers. Greatly simplified construction. More reliable and easier to build. Kit includes all necessary parts (except case). For P.C. board add \$3.00; AC XFMR add \$1.50. Do not confuse with Non-Alarm kits sold by our competition! Eliminate the hassle - avoid the 5314!
NEW! WITH JUMBO LED READOUTS!

1000 MFD Filter Caps Rated 35 WVDC Up-right style with PC leads. Most popular value for hobbyists. 4/\$1.00	SLIDE SWITCH Assortment Our best seller. Includes miniature and standard sizes, single and multi-position units. All new. 12/\$1.00	POWER RESISTOR 15 OHM 25W BY CLAROSTAT 75¢ ea.	RESISTOR ASSORTMENT 1/4W 5% & 10% PC leads. A good mix of values! Special! 200/\$2.	P.C. LEAD DIODES 1N4148/1N914 100/\$2. 1N4002 - 1A 100 PIV 40/\$1.	Just received a good mixed lot of National TO-92 plastic transistors. PNP & NPN, even a few FET's. 40-50% yield. Untested Asst. 500/\$3.	DISC CAP ASSORTMENT P.C. Leads. At least 10 different values. Includes .001, .01, .05 plus other standard values. 60/\$1.00
---	---	---	---	---	---	---

AMD-1702A
Huge Factory Purchase
 FACTORY PRIME UNITS! BRAND NEW!
 1.5 Micro-Seconds Access Time.
 10/\$40. \$4.95 ea.

★ *Special!* ★

3.579545 MHz Time Base Crystal \$1.25

28 PIN SOCKETS 3 for \$1.00

11,000 MFD 50WVDC Computer Grade Cap \$3.00 each

39 MFD 16 V Mallory Electrolytic 15 for \$1.00

FACTORY PRIME! 21L02-1

Not only are our RAM'S faster than a speeding bullet but they are now very low power. We are pleased to offer prime new 21L02-1 Low Power and Super Fast RAM'S. Allows you to STRETCH your power supply farther and at the same time keep the wait light off!

500ns 8/\$12.95
 250ns 8/\$15.95

IC'S REMOVED FROM PC BOARDS ALL TESTED; FULL SPEC.

IC's from XEROX

1402 A Shift Regulator - 50c
 MH0025CN - 55c

7400 - 9c
 7402 - 9c
 7404 - 9c
 7406 - 11c
 7407 - 11c
 7410 - 9c
 7416 - 13c
 7420 - 9c

7430 - 9c
 7440 - 9c
 7437 - 10c
 7438 - 10c
 7451 - 9c
 7474 - 16c
 7475 - 24c
 7486 - 16c

7493 - 26c
 74121 - 22c
 74123 - 32c
 74151 - 9c
 74155 - 22c
 74193 - 35c
 8233 - 35c
 Intel - 1302 - 45c

Great Buy!

MOS 6 DIGIT UP/DOWN COUNTER

40 PIN DIP. Everything you ever wanted in a counter chip. Features: Direct LED segment drive, single power supply (12 VDC TYPE), six decades up/down, pre-loadable counter, separate pre-loadable compare register with compare out-put. BCD and seven segment outputs, internal scan oscillator, CMOS compatible, leading zero blanking. 1MHZ. count input frequency.

\$12.95 Exclusive! \$12.95

CALL IN YOUR BANK-AMERICARD OR MASTER CHARGE ORDER IN ON OUR CONTINENTAL UNITED STATES TOLL FREE WATTS LINE:

1-800-527-3460

Texas Residents Call Collect:

214/271-0022

TERMS:

Money Back Guarantee!

NO COD'S. TEXAS RESIDENTS ADD 5% SALES TAX. ADD 5% OF ORDER FOR POSTAGE & HANDLING. ORDERS UNDER \$10.00 ADD 75c. FOREIGN ORDERS - U.S. FUNDS ONLY!

Orders over \$15. - Choose \$1. FREE MERCHANDISE!

GODBOUT

BILL GODBOUT ELECTRONICS
BOX 2355, OAKLAND AIRPORT, CA 94614

TERMS: Prices good through end of magazine cover date. Cal res add tax. BankAmericard®/VISA®/Mastercharge® orders (\$15 min) call (415) 562-0636, 24 hrs. Allow up to 5" shipping (more for power supplies); excess refunded. COB orders OK with street address.

ADD 24K OF MEMORY TO YOUR COMPUTER — \$450

Now you can buy 3 of our popular 8K ECONORAM II™ boards for \$450. Features? All static design (eliminates dynamic timing hassles); tri-state outputs; configured as two separate, independent 4K blocks with individual protect for each block; zero wait states (4 MHz - 800; use 1 wait state, implemented on board); provides vector interrupt if write attempted in protected block. Fully buffered. Fully socketed. True low power.

#SPC-24 Three 8K ECONORAM II kits.....\$450.00
#CK-008 8K ECONORAM II (kit form).....\$163.84
#CK-010 Same but assembled, tested, 1 yr warr.....\$188.50
#CK-007 4K ECONORAM II (kit form).....\$100.00
#CK-009 Same but assembled, tested, 1 yr warr.....\$120.00

FOR MORE DETAILS, COMPONENTS + MUCH MORE...

SEND FOR OUR FLYER

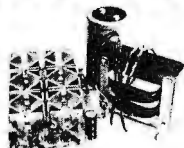

12A at 50% duty cycle.
.05V regulation, current limiting, crowbar over-voltage protection. Easy to build, compact kit.
Excellent for powering ham, CB, and automotive equipment from the AC line. Please include sufficient postage; case & hardware not included.

12V 8A SUPPLY \$39.95

MOTHERBOARDS
10 SLOT \$ 90
18 SLOT \$ 124

Both kits include edge connectors. Active terminations reduce noise, crosstalk, and other bus problems.

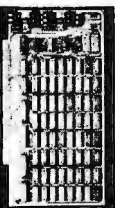

INTERDESIGN 100 PULSE GENERATOR

\$88

Portable, rechargeable, 10% - 90% duty cycle.
.1 Hz to 2 MHz.

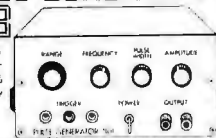

PARTS SPECIALS
#SPC-22 Prime 8080A...\$12.95
#SPC-23 Fast 2708...\$25.00

CIRCLE NO. 28 ON FREE INFORMATION CARD

For faster service

USE ZIP CODE

on all mail

PROMS PROGRAMMED — New low prices — 13 cents stamp brings information. Or send \$1 check for program cards, specs, PROM postage credit. RBH Enterprises, Box 12344, Wichita, KS 67277.

COMBO ORGAN 61 Note C to C includes Synthesizer — Piano Section — 1' 2' 4' 8' 16' Percussion Rotary Sustains — Case Vinyl and Stand. Special \$325.00. Elm Systems, 205 East 17th Street, New York, New York 10003.

SNOOPERSCOPE, see in total darkness with infrared viewing device. Detailed construction plans, \$3.50. Argyre, Box 1570, Laporte, TX 77571.

PC BOARDS from your art. Send SASE for info. Assembly Systems, Box 221, Wadsworth, OH 44281.

8080 OCTAL REFERENCE CARD. Program your 8080 GPU in easy Octal. Complete reference card with op codes, S-100 pin-outs, ASCII. \$1.25 postpaid. ThinkerToys, 1201-10th St., Berkeley, CA 94710.

FREE CATALOG. Solar Cells, Nicads, Kits, Calculators, Digital Watch Modules, Ultrasonics, Strobos, LEDs, Transistors, IC's, Unique Components, Chaney's, Box 27038, Denver, CO 80227.

SEEKING JAPANESE TRANSISTORS FOR CB REPAIR? Request list. Fujii-Svea Enterprises, Dept. P, Box 40325, Cincinnati, OH 45240.

PRINTED CIRCUIT BOARDS from artwork, magazine layouts. Fast service. OMEGA ENTERPRISES, Box 48239, Niles, Ill. 60648.

MICROCOMPUTER SYSTEMS. Troubleshooting Techniques-Digital Gate Decode Chart, both \$5.00. Micro Info Assoc., Box 849, Castroville, Calif. 95012. Calif. residents add 6% tax.

CLASSIFIED ADVERTISING ORDER FORM

1	2	3
4	5	6
7	8	9
10	11	12
13	14	15
16	17	18
19	20	21
22	23	24
25	26	27
28	29	30

Please refer to heading on first page of this section for complete data concerning terms, frequency discounts, closing dates, etc. WORD COUNT: 15 WORD MINIMUM. Include name and address.

Words

\$2.25 (Commercial Rate)
\$1.35 (Reader Rate)
\$3.35 (Expand-Ad Rate)

Payment of \$ enclosed for _____ insertions.
 AmEx BAC MasterCard
 MC Diners

CHARGE for _____ insertions.
You will be billed monthly.
Account # _____

Expiration Date _____
Master Charge Interbank # (4 digits above name) _____

SIGNATURE MUST BE PROVIDED BELOW.

PRINT NAME _____

ADDRESS _____

CITY _____ STATE _____ ZIP _____

SIGNATURE _____ PE-977

Toshiba Transistor Amplifier Module

XM-670

4.99
Reg. 6.99

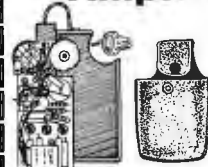

•Experimenters Delight
•100's of Uses •Some Marred & Soiled

BSR

METROTEC

Smoke & Fire

XM-646

Detector

14.99
Reg. 19.99

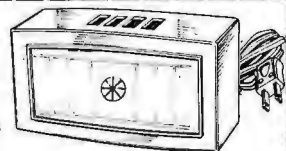

•Protect Your Family From Fire and Killer Gases
•117 VAC Powered

NICKEL CADMIUM "AA" Pen-Lite Cells

\$1 BA-341 Ea.

•1.2 Volt Rechargeable
•For Radios and Calculators Etc.



	Reg.	Now
AM Pushbutton Auto Radio-New, AU-580	10.99	9.99
Sonar 30-50 MHz (3-Ch.) plus AM std. Broadcast Pocket Receiver, RA-577	39.00	29.99
Sonar 150-174 MHz. (3-Ch.) plus AM std. Broadcast Pocket Receiver, RA-422	39.00	29.99
Electronic Camera Shutter Assembly, XM-637	1.49	
Singer 12 Digit MOS Calculator Chip with Data Sheet, XM-635	2.98	2.29
UHF Varactor Tuner, Data Incl., XM-676	1.99	1.49
Electronic "Choo-Choo" Module for Model Railroad, AM-549	1.99	.99
Siphon Pump-6 ft. Squeeze Type, XM-675	.59	.39
6 VDC to 12 VDC Converter, AU-297	16.00	7.00
4 Channel Converter for Car Stereo, HF-216	7.98	2.00
Timing Motor 1 Rev. Every 4 Hours 120 VAC., MO-407	1.69	.99
Telechron Digital Clock Movement, 1/4" Numerals, 117 VAC., 60 Hz. Removed from Equip., SW-853	5.99	4.99
2 1/4" 60 Ohm Speaker, SP-435	1.19	.69
AM-FM-MPX Receiver Chassis, Solid State 11-12 VAC Input. Tape Out Jacks, RA-574	9.99	7.99
Universal AC Adapter, 117 VAC Input, 6-7.5 and 9 VDC Output @ 300 Ma., BA-159	7.00	4.99

FREE CATALOG

Olson electronics

260 S. FORGE ST.
DEPT. 13 AKRON, OHIO 44327

NAME _____
ADDRESS _____
CITY _____ STATE _____
ZIP _____ Send Olson Cat.

ENCLOSE POSTAGE AND SALES TAX

QTY.	STK. #	Description	Price Ea.	Total

CIRCLE NO. 44 ON FREE INFORMATION CARD

SEPTEMBER 1977

MIND-ABSORBING PROJECTS FOR EXPERIMENTERS AND HOBBYISTS

1978 ELECTRONIC
EXPERIMENTER'S
HANDBOOK



ELECTRONIC EXPERIMENTER'S HANDBOOK

Published each year by the editors of Popular Electronics, here's the one publication that helps you get it together... with a score of build-it-yourself projects.

The all-new 1978 edition goes on sale nationally October, 1977

It will again be packed with features and articles and complete lab-tested instructions that are sure to guarantee successful days and months of mind absorbing projects for fun and practicality.

RESERVE
YOUR COPY NOW
AT THE
PRE-PUBLICATION
PRICE OF
ONLY \$1.50

This offer is being made to readers of Popular Electronics only. Regular price is \$1.95; mail order \$2.50. Save money and enjoy the convenience of having the 1978 ELECTRONIC EXPERIMENTER'S HANDBOOK mailed to you from first-off-the-press copies when published. Complete the Reservation Form and return it promptly with your remittance.

PRE-PUBLICATION RESERVATION FORM

Electronics Experimenter's Handbook
Consumer Service Division
595 Broadway, N.Y., N.Y. 10012 PE-977

Enclosed is \$1.50* (outside U.S.A. \$2) for my copy of the 1978 ELECTRONIC EXPERIMENTER'S HANDBOOK to be mailed to me in October, 1977 when published.

Print Name _____
Address _____
City _____
State _____ Zip _____

*Residents of CA, CO, FL, IL, MI, MO, NY STATE, DC and TX add applicable sales tax.

CARTRIVISION OWNERS! Sony Color Tuner/Modulator plugs into Cartrivision. Record off channels not viewed. Record without TV on. Play into any TV without interfacing. \$250.00. (Specify channel 3/4). D.H.V., Inc., Box 12, Langhorne, Pennsylvania 19047.

ALL SOLID STATE DIGITAL OSCILLOSCOPE, digital memory dual trace, 1mV Dc-5MHz, batt. operated, 2X2.5" display pocket-size, complete PLANS, PICTURES, parts list & sources \$15. Pictures-into \$1, SEECOM, Box 1274, Tustin, CA 92680.

ALL TOP QUALITY BRANDS COMPONENTS. No down payment. 36 hour delivery anywhere in U.S. No-Lemon Guarantee. Altec, Bose, Cerwin-Vega, DBX, Infinity, Lux, Micro-Acoustics, OHM, Phase-Linear, others. International Hi-Fi Distributors, Moravia Center Industrial Park, Balto., Maryland 21206. Phone: (301) 488-9600.

FREQUENCY LISTS: Shortwave and VHF-UHF. Military, Aviation, Satellite, Police, more. Sample \$2.00. Catalog 50 cents. HANDLER, Box 253, Deerfield, Illinois 60015.

HARDCOPY: Attachment converts most electric typewriters to microcomputer printout. Free Brochure. Stout Microcomputer, Box 1573, Fremont, CA 94538.

BOOKS AND MAGAZINES

ELECTRONICS DICTIONARY — 688 page industry standard reference filled with 16,000 up-to-date technical definitions and diagrams. Outstanding \$6.95 retail value for \$4.50 wholesale price (postage included). ANRI, P.O. Box 3727, Torrance, CA 90510.

TECHNICAL MANUALS — Ameco, Arrl, Cowan, Giffler, Rider, RCA Radio Callbook, Sams, Tab, T.I. Postage 35 cents bk, ppd. Five. Madison Electronics, 1508 McKinney, Houston, Texas 77002.

FREE book prophat Elijah coming before Christ. Wonderful bible evidence. Megiddo Mission, Dept. 64, 481 Thurston Rd., Rochester, N.Y. 14619.

BURGLAR ALARMS

WHY WORRY about leaving car lights on? EASILY INSTALLED ALARM alerts, with pulsing tone. \$12.95. CFL Enterprises, P.O. Box 415, Export, PA 15632.

NEW SUPER SENSITIVE HOME/AUTO BURGLAR ALARM SYSTEM

Patented Electronic Perimeter Devices Easily Installed by Almost Anyone.

On guard against burglars by means of loud alarm triggered by break-in attempts. Almost uncanny the way it senses danger from unauthorized intruders. Requires NO switches, door cords, shunt locks, for traps or delays. So nearly wireless one small Control with sensors can protect up to 50 GLASS doors, windows, walls, Etc. using one single 28 gauge wire. Great opportunity for persons seeking professional protection at low cost. Send \$1.00 for Full details.

KING RESEARCH LABS, INC.

312/344-7877

801 South 11th Avenue, Maywood, IL 60153

PROTECTION! Build your own fire/burglar alarm. Complete plans. Send \$5.50 to: Triangle, Box 9244, Wichita, KS 67277.

Burglar . Smoke Fire Alarm Catalog

• Billions of dollars lost annually due to lack of protective warning alarms.

FREE CATALOG Shows you how to protect your home, business and person. Wholesale prices. Do-it-yourself. Free engineering service.



Burdex Security Co.

Box 82802 PE-097 Lincoln, Ne. 68501

EDI

VOICE ACTIVATED SOLID STATE SWITCH
Locks on when activated and opens when input is momentary. Instrumented. Features factory adjustment.
Special \$1.88

5CPT OSCILLOSCOPE TUBE
Limited Quantity
• New Dumont 4CPT Scope Tube
• Use in Many Older Test Scope Oscilloscopes
• Stock One Now if Your Oscilloscope is Old
N-189 \$44.00 Value 4.88

24-KEY DESK CALCULATOR KEYBOARD
• Touch tone type contacts • Complete on circuit board • Flare keys and 4 slide switches • 7.5x5.5 x 3.1118 D x 1.314" highest point • 1/16" lowest point • Shipping Wt. 1.1 lb.
E-206 .99

DIGITAL CLOCK MOVEMENT
• Five Digit Numerals 5 1/8" High
• Made by Shurex, Shure, Acco
• 12V AC 60Hz
• Size 4.3" W x 1.1" H x 3.0" D
• Shipping Wt. 1 lb.
Q-47 2.99

4-DIGIT ITT GENERAL CONTROL RESETTABLE COUNTER
• 120-Volt 60-Hz
• Model #CE40AS402
• Minimum Make Time .050 Second, Break Time .050 Second
• Enclosed in Tamperproof Case
• Shipping Wt 1 Lb
N-98 1.99 \$1.30

2" PANEL METER 50-0-50 UA DC MICROAMMETER
• Wide View Panel Meters
• 2-3/8" x 1-13/16" Face
• Mounts in 1 1/2" Hole
F-20 1.99

4-RANGE DIGITAL READOUT INTERVAL TIMER KIT
• 4 time functions: 1-9.9 Sec., 1-99 Sec., 1-9.9 Min., 1-99 Min.
• 1/2" High Nixie Tube Readouts
• For classroom use in both processing & enlarging processes
• As a timer for sport & contest events (stop switch)
• Provides timed 120V AC outlet and S.P. NO contact to trigger buzzer alarm or visual signals
• Full Wiring Instructions included - No Cabinet or Case Available For Timer
E-207 100.00 VALUE Accurate to 1/10 of 1% • 140 for Visual Design SPECIAL 19.99

DYNAMIC DIGITAL TRANSISTOR CHECKER
Tests transistors in circuit or out of circuit. The Dynamic Transistor Checker lets you match transistors in working circuits to improve the operation. It will test Go and No Go at currents from 5ma to 50ma, and will show current gain, electrical open and short circuits. Tests low, medium and high power transistors both PNP and NPN types. Complete with transistor socket test clips and leads. Uses VM2 or C1 1/2V battery. Size of case 6 1/2" x 3 1/2" x 2".
F-14A 9.99

DC POWER SUPPLY
This DC power supply will deliver four ranges of DC voltages: 4.5V, 8V, 9V and 12V. It will supply a fully filtered output of one of these voltages at 150 milliamperes capacity. Can be used for any DC power supply within the voltage range and capacity, such as: operating a small battery radio; operating a small calculator, or powering microcomputer laboratory experiments. Uses standard 117V 60C AC power. Output binding posts accept wire or banana plugs. With 4 1/4" PL cord and plug. Size of case: 5" x 2-5/8" x 1-5/8".
F-145 15.88 Value 5.99

TRANSISTORIZED SIGNAL TRACER
EDI Special!
This transistorized signal tracer can be used by technicians and service men to exactly trace signals of RF and IF and audio circuits from the antenna to the speaker stage by stage. An ideal tool for servicing audio equipment, amplifiers, tuners, receivers, turntables, etc. Has 2" speaker and test leads. Uses N556 9V transistor battery. Size of case: 5" x 2-5/8" x 1-5/8". Leads and Instructions included.
Was 17.88
F-171 7.77

22-RANGE BENCH STYLE MULTI-TESTER WITH DECIBEL SCALE
• Taut Band Suspension Meter
• Extra Wide Two Color Mirrored Scale Assures Accurate Readings
SPECIFICATIONS:
Sensitivity: 30,000 Ohm Volt DC 10,000 Ohm Volt AC, DC Volt: 0.5 2.5 5 15 50 250 500 1,000 2,500 AC Volt: 15 50 150 500 1,000 DC Current: 50ua 5ma 50ma 150ma 500ma 5 Amp Ohm: RX1 RX10K RX10K Decibel: 20 to +60db Size: 4 1/2" x 8 1/2" x 3 1/2"
Was 39.88
F-496 26.88

SEND FOR FREE CATALOG with hundreds of electronic items
Minimum order \$3.00. Add \$2.00 per page shipping and handling charge. No cash orders. No orders shipped outside the U.S. No orders shipped outside the U.S. No orders shipped outside the U.S.
EDI
Dept. PE1, 4900 Elston, Chicago, IL 60630 • Tel: 312-283-4880

CRYSTALS

THESE FREQUENCIES ONLY

Part #	Frequency	Case/Style	Price
CY1A	1.000 MHz	HC33 U	\$5.95
CY2A	2.000 MHz	HC33 U	\$5.95
CY2 01	2.010 MHz	HC33U	\$1.95
CY3A	4.000 MHz	HC18 U	\$4.95
CY7A	5.000 MHz	HC18 U	\$4.95
CY12A	10.000 MHz	HC18 U	\$4.95
CY14A	14.31818 MHz	HC18U	\$4.95
CY19A	18.000 MHz	HC18 U	\$4.95
CY22A	20.000 MHz	HC18 U	\$4.95
CY30B	32.000 MHz	HC18 U	\$4.95

XR-2206KB Kit \$29.95 Special XR-2206KA Kit \$19.95

EXAR TIMERS

Part #	Price	Part #	Price
XR-205	\$8.40	XR-555CP	\$ 3.39
XR-2205CP	\$ 4.49	XR-320P	1.55
XR-2207CP	\$ 9.95	XR-555CP	1.85

MISCELLANEOUS

Part #	Price	Part #	Price
XR-2211CP	\$8.70	XR-2240CP	2.25
XR-4136	99	PHASE LOCKED LOOPS	
XR-1310CP	\$3.20	XR-1466	3.85
XR-1310CP	3.20	XR-1468	3.80
XR-1800P	2.99	XR-1480	4.80
XR-2567	2.99	XR-2208	5.20
		XR-567CT	1.70

CONNECTORS

PRINTED CIRCUIT EDGE-CARD

156 Spacing-Tin-Double Read-Out

Bifurcated Contacts — Fits .054 to .070 P.C. Cards

Part #	Price	Part #	Price
15/30	PINS (Solder Eyelet)	\$1.95	
18/36	PINS (Solder Eyelet)	\$2.49	
22/44	PINS (Solder Eyelet)	\$2.95	
50/100	PINS (Wire Wrap)	\$6.95	
50/100A (.100 Spacing)	PINS (Wire Wrap)	\$6.95	

25 PIN-D SUBMINATURE

Part #	Price	Part #	Price
DB25P	PLUG	\$3.25	
DB25S	SOCKET	\$4.95	

IMS 3 1/2 DIGIT DVM KIT

This D-2 VDC .05 per cent digital voltmeter features the Motorola 3 1/2 digit DVM chip set. It has a 4" LED display and operates from a single -5V power supply. The unit is provided complete with an injection molded black plastic case complete with Bezel. An optional power supply is available which fits into the same case as the D-2 VDC allowing 117 VAC operation.

A. 0-2V DVM with Case \$49.95

B. 5V Power Supply \$14.95

Etching Kits

Part #	Description	Price
32 X A-1	P.C. Etch Materials Kit enough for 5 circuit boards	\$29.95 ea.
27 X A-1	Etched Circuit Kit Complete kit — only add water	\$ 9.95 ea.

Plugboards

Part #	Description	Price
3662	6.5 x 4.5 x 1/16 Epoxy glass P-Pattern-44 P.C. Tabs-spacing 156"	\$ 6.95 ea.
22/44	Mating connector for plugboard — 22 pin double readout	\$ 2.95 ea.
8800V	Universal Microcomputer-Processor plugboard — Epoxy Glass — complete with heatsink and mounting hardware 5 3/16 x 10 x 1/16 copper clad	\$19.95 ea.

1/16 VECTOR BOARD

Part #	Description	Price
PHENOLIC	64P-41 0623XNP	4.50
	169P-4 022XPX	4.50
EPDXY	64P-4 062	4.50
GLASS	84P-4 062	4.50
	169P-4 062	4.50
EPDXY GLASS	169P-4 062	4.50
COPPER CLAD	169P-4 062C1	4.50

SLIT-N-WRAP WIRE WRAP TOOL

Slits and opens insulation exposing bare wire

- No pre-cutting or pre-stripping.
- Comes complete with two - 100 ft spools #28 AWG wire

Model P180 \$24.50

HEXADECIMAL ENCODER 19-KEY PAD

1 - 0

• ABCDEF

• Return Key

• Optional Key (Period)

• — Key

\$10.95 each

63 KEY KEYBOARD

This keyboard features 63 uncoated SPST keys, unattached to any kind of P.C.B. A very solid injection molded plastic 13" x 4 1/2" base suits most applications.

\$24.95

TOOLS

A97MS	Diagonal Cutter - 4" semi-flush cut	\$8.50 ea.
A11DMS	Chain Nose Pliers - 4 3/4" long	7.50 ea.
T-6	Wire Stripper - #16 to #26 gauge	3.75 ea.
55B	Wire Stripper - #10 to #20 gauge	2.50 ea.
CS-8	Cutter-Crimper Tool - 8 3/4" long	8.50 ea.
Nibbling Tool	Cuts, Trims or Notches Metal up to #18 gauge	6.95 ea.
Nibbling Tool Replacement Punch		3.75 ea.

PERMACEL™ P-29 PLUS

Electrical Tape - All Weather

1/4" wide x 95 ft. Black Vinyl

1-9 Rolls \$7.99 each 10-up Rolls \$6.95/10 roll package

MICROPROCESSOR COMPONENTS

Part #	Description	Price	Part #	Description	Price
8080A	CPU	\$19.95	8228	System Controller - Bus Driver	\$10.95
8212	8 Bit Input/Output	4.95	MC6800L	8 Bit MPU	35.00
8214	Priority Interrupt Control	15.95	MC6820L	Periph. Interface Adapter	15.00
8216	Bi-Directional Bus Driver	6.95	MC6801AP1	128 x 8 Static RAM	6.00
8224	Clock Generator/Driver	10.95	MC6830L8	1024 x 8 Bit ROM	18.00
CDP1802	with user manual	39.95	Z80	CPU	49.95

Part #	Description	Price	Part #	Description	Price	
8080	Super 8088	24.95	RAM'S	Static	\$ 1.49	
8080A	Super 8088	19.95	2101	256 x 4	Static	1.49
2650	8 BIT MPU	26.50	2102	1024 x 1	Static	1.75
			2107/4260	4096 x 1	Dynamic	4.95
2504	1024 Dynamic	\$ 3.95	2111	256 x 4	Static	5.95
2518	Hex 32 Bit	7.00	2189	16 x 4	Static	2.49
2519	Hex 40 Bit	4.00	8101	256 x 4	Static	6.95
2524	512 Dynamic	2.49	8111	256 x 4	Static	6.95
2575	1024 Dynamic	6.00	8939	16 x 4	Static	3.49
2527	Dual 256 Bit	3.95	11101	1024 x 1	Static	2.25
2529	Dual 512 Bit	4.00	2420	296 x 1	Static	9.95
2532	Quad 80 Bit	3.95	93421	256 x 1	Static	2.95
2533	1024 Static	Saecon 5.95	MMS202	2K x 1	Dynamic	2 for 1.00
3341	Fifo	6.35	1702A	2048	Fammos	\$ 9.95
74LS670	16 x 4 Reg	3.45	SMTS	2048	Fammos	13.95

SPECIAL REQUESTED ITEMS

Part #	Price	Part #	Price
FDM3817	\$ 5.00	8797	2.00
AY-3-8500-1	\$16.95	33A1	6.95
MC3051P	3.50	CD4051	3.95
MC4016P (74416)	7.50	CD4515	6.50
MC14953	3.50	CD4320	2.70
MC14552	14.50	MC68571	17.50
CD4059	9.95	MC68574	17.50
CD4070	95	MC6575	17.50
MC14009	14.95	MC14419	14.95
MC14410	14.95	ICM7045	24.95

PARATRONICS

Featured on February's Front Cover of Popular Electronics

MODEL 100A

Logic Analyzer Kit \$189.00/Kit

Some applications are:

- Troubleshooting microprocessor address, instruction, and data flow
- Examining contents of ROMS
- Tracing operation of control logic
- Checking counter and shift register operation
- Monitoring I/O sequences
- Verifying proper system operations during testing

Kit includes case, bracket and all components — complete.

Kit: \$49.95

ASSEMBLED: \$59.95

BUGBOOK

Continuing Education Series

BUGBOOK I & II - Basic concepts of TTL Logic — over 90 experiments \$17.00/set

BUGBOOK IIa - Introduces UART — recommended for RTTY enthusiast \$5.00/book

BUGBOOK III - Explores 8080 chip — introduces Mark 80 Microcomputer \$15.00/book

555 TIMER APPLICATIONS SOURCEBOOK WITH EXPERIMENTS — over 100 design techniques \$6.95/book

CMOS-M-DESIGNERS PRIMER AND HANDBOOK a complete CMOS instruction manual \$6.00

CONTINENTAL SPECIALTIES

PROTO BOARD 6

(6" long X 4" wide) \$15.95

Other CS Proto Boards

PB100 - 4.5" x 6"	\$ 19.95
PB101 - 5.8" x 4.5"	29.95
PB102 - 7" x 4.5"	39.95
PB103 - 9" x 6"	59.95
PB104 - 9.5" x 8"	79.95
PB203 - 9.75 x 6 1/2 x 2 1/2	75.00
PB203A - 9.75 x 6 1/2 x 2 1/2	120.00

(includes power supply)

Logic Monitor \$84.95

for TTL, HTL or CMOS Devices

PROTO CLIPS

14 PIN	\$4.50
16 PIN	4.75
24 PIN	8.50

DESIGN MATES

DM1 - Circuit Designer	54.95
DM2 - Function Generator	69.95
DM3 - RC Bridge	59.95

QT PROTO STRIPS

Part #	Description	Price
QT-595	595	2.50
QT-598	598	2.50
QT-478	478	10.00
QT-555	555	8.50
QT-598	598	2.00
QT-185	185	4.75
QT-125	125	3.75
QT-85	85	3.25
QT-75	75	3.00

EXPERIMENTER 300

\$ 9.95

EXPERIMENTER 600

\$19.95

55.00 Minimum Order — U.S. Funds Only

Spec Sheets - 25¢ — Send 35¢ Stamp for 1977A Catalog

California Residents — Add 6% Sales Tax

Dealer Information Available

James ELECTRONICS

1021-A HOWARD AVE., SAN CARLOS, CA. 94070

PHONE ORDERS WELCOME — (415) 592-8097

All Advertiser Prices Good Through September

Timeband Digital Alarm Clocks

A trademark of Farcom Camera and Instrument Corporation

24-hour alarm

Doze Button

100% Solid State

Large Red LED Display (8 high)

AM-PM Indicator

Seconds display at touch of button

Power failure indicator

One year factory warranty

C-500 Ivory Case \$16.95

C-8211 Woodgrain Case \$19.95

Timeband LAMP CLOCK

by FAIRCHILD

24 hour alarm

Doze button

Alarm-on indicator

.8" high Red LED Display

AM/PM Indicator

High intensity lamp

Lamp shuts off when collapsed

Model C-590 (l) \$29.95

DIGITAL AUTO INSTRUMENT

SEVEN DIFFERENT INSTRUMENTS!
MEETS OR EXCEEDS ORIGINAL AUTOMOTIVE SPECS.

Please specify which one of the seven models you want when ordering — these do not all come in one unit. Each model must be bought separately.

1 TACHOMETER
1 0-3000 RPM
4 6 or 8 Cylinders

2 WATER TEMP.
100-250° F

3 FUEL LEVEL
Percentage
Low Fuel indicator

4 SPEEDOMETER
0-99 MPH

5 OIL PRESSURE
0-80 PSI

6 OIL TEMP.
200-350° F

7 BATTERY MONITOR
± 1 Volts From 11-15 VDC

BRIGHT YELLOW ORANGE
3" LED DISPLAY!

Kit includes case, bracket and all components — complete.
Nothing else to buy! 12 Volt NEG GRD.

DIMENSIONS 4 1/2 x 4 x 2

Kit: \$49.95
ASSEMBLED: \$59.95

DIGITAL STOPWATCH

Bright 6 Digit LED Display

Times to 99 minutes 59.99 seconds

Crystal Controlled Time Base

Three Stopwatches in One

Times Single Event — Split & Taylor

Size 4 1/2" x 2 1/4" x 1 3/8" (1 1/2 ounces)

Uses 3 Panicle Cells

Kit — \$39.95

Assembled — \$49.95

Heavy Duty Carry Case \$5.95

Stop Watch Chip Only (7205) \$19.95

QUARTZ DIGITAL AUTO CLOCK OR ELAPSED TIMER!

Elapsed Timer: Hrs, Mins and Secs
12 or 24 Hr Capacity
Simple Reset - Start Pushbutton Control

Complete kit includes mounting bracket, case and all components, nothing else to buy. Features MMS314 chip. Large 4" LED's. Accuracy better than many per cent. Internal battery backup. 12 volt neg-polar operation

Kit: \$29.95
Assembled: \$39.95

CASE ONLY (includes hardware, mounting bracket and bezel) \$6.50

JE700 CLOCK

The JE700 is a low cost digital clock, but is a very high quality unit. The unit features a simulated walnut case with dimensions of 5 x 2 1/2 x 1. It utilizes a MAN72 high brightness readout, and the MMS314 clock chip.

12 or 24 Hour

115 VAC

\$17.95

DIGITAL CLOCK KIT — 3 1/2 INCH DIGITS

4 DIGIT KIT \$48.95

6 DIGIT KIT \$69.95

4 DIGIT ASSEMBLED \$59.95

6 DIGIT ASSEMBLED \$79.95

This clock features big 3 1/2" high digits for viewing in offices, auditoriums, etc. Each digit is formed by 31 bright 0.2" LED's. The clock operates from 117 VAC, has either 12 or 24 hr. operation. The 6 digit version is 27" x 3 1/2" x 1 1/2" and the 4 digit is 18" x 3 1/2" x 1 1/2". Kits come complete with all components, case and transformer.

Specify 12 or 24 Hour When Ordering

JE803 PROBE

The Logic Probe is a unit which is for the most part indispensable in troubleshooting logic families TTL, DTL, RTL, CMOS. It derives the power it needs to operate directly off the circuit under test, drawing a scant 10 mA max. It uses a MAN3 readout to indicate any of the following states: these symbols: H (1), L (LOW), 0 (PULSE), P (The Probe can detect high frequency pulses to 45 MHz. It can't be used at MOS levels or current damage will result.

\$9.95 Per Kit

printed circuit board

T-L 5V 1A Supply

This is a standard TTL power supply using the well known LM309K regulator IC to provide a solid 1 AMP of current at 5 volts. We try to make things easy for you by providing everything you need in one package, including the hardware for only

\$9.95 Per Kit

7400N TTL

SN7400N	.16	SN7459A	.25	SN74154N	1.00
SN7401N	.16	SN7460N	.22	SN74155N	1.00
SN7402N	.21	SN7470N	.45	SN74156N	.99
SN7403N	.16	SN7472N	.39	SN74157N	.99
SN7404N	.18	SN7473N	.37	SN74158N	1.25
SN7405N	.24	SN7474N	.50	SN74161N	.99
SN7406N	.20	SN7475N	.56	SN74162N	.99
SN7407N	.29	SN7476N	.32	SN74163N	1.10
SN7408N	.25	SN7479N	5.00	SN74165N	1.10
SN7409N	.25	SN7480N	.30	SN74166N	1.25
SN7410N	.18	SN7481N	.99	SN74167N	1.25
SN7411N	.30	SN7483N	.70	SN74170N	5.90
SN7412N	.33	SN7485A	.89	SN74172N	8.95
SN7413N	.45	SN7486N	.39	SN74173N	1.50
SN7414N	.70	SN7488N	2.35	SN74174N	2.25
SN7416N	.35	SN7489N	2.49	SN74175N	.99
SN7417N	.35	SN7490N	.45	SN74176N	.90
SN7420N	.21	SN7491N	.75	SN74177N	.90
SN7421N	.33	SN7492N	.49	SN74178N	.90
SN7422N	.49	SN7493N	.45	SN74179N	.99
SN7425N	.37	SN7494N	.79	SN74181N	2.49
SN7425N	.29	SN7495A	.79	SN74182N	.95
SN7426N	.29	SN7496N	.89	SN74184N	1.95
SN7427N	.37	SN7497N	4.00	SN74185N	2.00
SN7428N	.22	SN7498N	1.00	SN74186N	15.00
SN7430N	.26	SN74107N	.39	SN74187N	6.00
SN7432N	.31	SN74121N	.39	SN74188N	3.95
SN7437N	.27	SN74122N	.39	SN74190N	1.19
SN7438N	.27	SN74123N	.60	SN74191N	1.25
SN7439N	.25	SN74124N	.60	SN74192N	2.89
SN7440N	.15	SN74126N	.60	SN74195N	1.25
SN7441N	.89	SN74132N	1.09	SN74194N	1.25
SN7442N	.59	SN74136N	.99	SN74195N	.75
SN7443N	.75	SN74141N	1.15	SN74196N	1.25
SN7444N	.75	SN74142N	4.00	SN74197N	1.79
SN7445N	.75	SN74143N	4.50	SN74198N	1.75
SN7446N	.81	SN74144N	4.50	SN74199N	1.75
SN7447N	.69	SN74145N	1.15	SN74200N	5.59
SN7448N	.79	SN74146N	2.00	SN74201N	6.00
SN7450N	.26	SN74148N	2.00	SN74251N	2.00
SN7451N	.27	SN74151N	1.00	SN74284N	6.00
SN7452N	.27	SN74151N	.79	SN74285N	6.00
SN7454N	.27	SN74157N	.89	SN74367N	7.00

MANY OTHERS AVAILABLE ON REQUEST
20% Discount for 100 Combined 7400's

CD4000	.25	CMOS	74004N	.75	
CD4001	.25	CD4030	74101N	.65	
CD4002	.25	CD4033	74202N	.65	
CD4003	2.80	CD4040	74003N	1.95	
CD4007	.25	CD4042	74422N	2.15	
CD4009	.59	CD4044	74073N	1.50	
CD4010	.59	CD4046	74074N	1.15	
CD4011	.25	CD4047	74093N	3.00	
CD4012	.79	CD4049	74094N	2.00	
CD4013	.47	CD4050	74107N	1.25	
CD4016	.56	CD4051	74051N	2.90	
CD4017	1.35	CD4052	74054	4.00	
CD4018	.55	CD4053	74055	3.25	
CD4020	1.49	CD4066	74160	3.29	
CD4022	1.25	CD4069	74161	3.25	
CD4023	.25	CD4071	74163	3.00	
CD4024	1.50	CD4081	74164	3.25	
CD4025	.25	CD4081	74164	3.25	
CD4026	\$3.95	CD4151	74073N	1.50	
CD4027	.69	MC1566	74093N	3.00	
CD4028	1.65	74000N	MC14014	.50	
CD4029	2.90	74022N	55	MC14016	.65

LINEAR

LM301CN	.60	LM351N	1.65
LM302CN	.60	LM442CN	1.75
LM303CN	.35	79M3	1.15
LM308N	1.00	LM370N	1.15
LM309N	1.00	LM373N	3.25
LM310CN	1.00	LM374N	1.15
LM311N	1.10	LM375N	1.95
LM312N	1.10	LM380CN	1.00
LM313N	1.10	LM381CN	1.00
LM314N	1.10	LM382CN	1.00
LM315N	1.10	LM383CN	1.00
LM316N	1.10	LM384CN	1.00
LM317N	1.10	LM385CN	1.00
LM318N	1.10	LM386CN	1.00
LM319N	1.10	LM387CN	1.00
LM320N	1.10	LM388CN	1.00
LM321N	1.10	LM389CN	1.00
LM322N	1.10	LM390CN	1.00
LM323N	1.10	LM391CN	1.00
LM324N	1.10	LM392CN	1.00
LM325N	1.10	LM393CN	1.00
LM326N	1.10	LM394CN	1.00
LM327N	1.10	LM395CN	1.00
LM328N	1.10	LM396CN	1.00
LM329N	1.10	LM397CN	1.00
LM330N	1.10	LM398CN	1.00
LM331N	1.10	LM399CN	1.00
LM332N	1.10	LM400CN	1.00
LM333N	1.10	LM401CN	1.00
LM334N	1.10	LM402CN	1.00
LM335N	1.10	LM403CN	1.00
LM336N	1.10	LM404CN	1.00
LM337N	1.10	LM405CN	1.00
LM338N	1.10	LM406CN	1.00
LM339N	1.10	LM407CN	1.00
LM340N	1.10	LM408CN	1.00
LM341N	1.10	LM409CN	1.00
LM342N	1.10	LM410CN	1.00
LM343N	1.10	LM411CN	1.00
LM344N	1.10	LM412CN	1.00
LM345N	1.10	LM413CN	1.00
LM346N	1.10	LM414CN	1.00
LM347N	1.10	LM415CN	1.00
LM348N	1.10	LM416CN	1.00
LM349N	1.10	LM417CN	1.00
LM350N	1.10	LM418CN	1.00
LM351CN	.65	LM1310N	2.95

Timeband by FAIRCHILD

— Watches —
Men's & Ladies

- Solid State
- Displays hour, minute, second, month & day
- Free set of replacement batteries
- Choose LED or LCD styles
- One year factory warranty



T249 White w/bracelet \$19.95
T248 Yellow w/bracelet \$22.95
LED



T2625 White w/strap \$29.95
T2624 Yellow w/strap \$34.95
LCD



T237 White w/bracelet \$22.95
T236 Yellow w/bracelet \$25.95
LED



TC437 White w/bracelet \$29.95
TC436 Yellow w/bracelet \$34.95
LCD



T325 White w/strap \$24.95
T324 Yellow w/strap \$27.95
LADIES LED

CHANNEL F

FAIRCHILD VIDEO ENTERTAINMENT SYSTEM

\$159.95

- Freeze Action • Speed Option
- Automatic time and scorekeeping
- Battery-free AC operation
- Dual controls with 8-way action
- Built-in Pro Hockey and Tennis games
- Easy hook-up on any B/W or Color TV
- Factory warranty

Channel F — additional cartridges — \$17.95 ea.

0811 — Tic-Tac-Toe/Shooting Gallery	0815 — Spaceman (2 players)	0813 — Blackjack (1 or 2 players)
0812 — Desert Fox/Shooting Gallery	0816 — Magic Numbers (computer logic)	0814 — Spitfire (1 or 2 players)
		0819 — Drag Strip (1 or 2 players)
		0820 — Maze (2 players)
		0822 — Baseball (2 players)

WIRE WRAP CENTER

HOBBY-WRAP TOOL-BW-630

- Battery Operated (Size C)
- Weighs ONLY 11 Ounces
- Wraps 30 AWG Wire onto Standard DIP Sockets (.025 inch)
- Complete with built-in bit and sleeve

\$34.95 (batteries not included)

WIRE-WRAP KIT — WK-2-W

WRAP • STRIP • UNWRAP

- Tool for 30 AWG Wire
- Roll of 50 Ft. White or Blue 30 AWG Wire
- 50 pcs. each 1", 2", 3" & 4" lengths — pre-stripped wire.

\$11.95

WIRE WRAP TOOL WSU-30

WRAP • STRIP • UNWRAP — \$5.95

WIRE WRAP WIRE — 30 AWG

25 ft. min. \$1.25 50 ft. \$1.95 100 ft. \$2.95 1000 ft. \$15.00
SPECIFY COLOR — White - Yellow - Red - Green - Blue - Black

WIRE DISPENSER — WD-30

50 ft. roll 30 AWG KYNAR wire wrap wire **\$3.45 ea.**

- Cuts wire to desired length
- Strips 1" of insulation Specify — Blue-Yellow-White-Red

HEAT SINKS

205-CB Beryllium Copper w/Black finish for TO-5	690-75A
291-36H Aluminum for TO-220 Transistors & Regulators	\$.25
680-75A Black Anodized Aluminum for TO-3	\$1.60
401-A Black Anodized Aluminum — pre-drilled mounting holes for TO-3	\$1.75

DIP SWITCHES SPST Slide Action

- #206-4 (8 pin dip) 4 switch unit **\$1.75 ea.**
- #206-7 (14 pin dip) 7 switch unit **\$1.95 ea.**
- #206-8 (16 pin dip) 8 switch unit **\$2.25 ea.**

TV GAME CHIP SET — \$14.95

Includes AY-3-8500-1 chip and 2,010 mbit crystal — if purchased separately would cost \$18.95.

DISCRETE LEADS

TYPE	POLARITY	HT	TYPE	POLARITY	HT
MAN 1	Common Anode	270 2 95	MAN 3640	Common Cathode-orange	300 1 75
MAN 2	5 x 7 Dot Matrix	300 4 95	MAN 1710	Common Anode-Red	400 1 95
MAN 3	Common Cathode	125 3 100	DL701	Common Anode-red	300 3 99
MAN 4	Common Cathode	187 1 95	DL704	Common Cathode	300 9 99
MAN 7	Common Anode	300 1 25	DL707	Common Anode	300 9 99
MAN 7G	Common Anode-green	300 1 95	MAN 4740	Common Anode-Red	400 9 99
MAN 52	Common Anode-yellow	300 1 99	DL741	Common Anode	600 1 99
MAN 66	Common Anode-orange	300 3 99	DL 747	Common Anode	600 2 25
MAN 64	Common Anode-red	400 9 99	DL 750	Common Cathode	600 2 49
MAN 74	Common Cathode	300 1 50	DL 338	Common Cathode	110 30
MAN 82	Common Anode-yellow	300 3 99	FND70	Common Cathode	250 75
MAN 84	Common Cathode yellow	300 3 99	FND533	Common Cathode	500 1 00
MAN 3820	Common Anode-orange	300 1 75	FND507	Common Anode	500 1 00

DISPLAY LEADS

TYPE	POLARITY	HT	TYPE	POLARITY	HT
MAN 1	Common Anode	270 2 95	MAN 3640	Common Cathode-orange	300 1 75
MAN 2	5 x 7 Dot Matrix	300 4 95	MAN 1710	Common Anode-Red	400 1 95
MAN 3	Common Cathode	125 3 100	DL701	Common Anode-red	300 3 99
MAN 4	Common Cathode	187 1 95	DL704	Common Cathode	300 9 99
MAN 7	Common Anode	300 1 25	DL707	Common Anode	300 9 99
MAN 7G	Common Anode-green	300 1 95	MAN 4740	Common Anode-Red	400 9 99
MAN 52	Common Anode-yellow	300 1 99	DL741	Common Anode	600 1 99
MAN 66	Common Anode-orange	300 3 99	DL 747	Common Anode	600 2 25
MAN 64	Common Anode-red	400 9 99	DL 750	Common Cathode	600 2 49
MAN 74	Common Cathode	300 1 50	DL 338	Common Cathode	110 30
MAN 82	Common Anode-yellow	300 3 99	FND70	Common Cathode	250 75
MAN 84	Common Cathode yellow	300 3 99	FND533	Common Cathode	500 1 00
MAN 3820	Common Anode-orange	300 1 75	FND507	Common Anode	500 1 00

FCS 8000A — 3 1/2 Digit — 8" Display

NEW! 25 Pin Version with color & amp/m indicator

- Connects almost easily for one with 3817, 3817A or D.
- (3817 available at \$5.00 each.)

FRONT VIEW — FCS8000
\$4.95 EA.
• MAXIMUM FORWARD CURRENT — 25 mA.

HP 5082-7300 Series — Multi-Digit

- 1/2" Ht. • Common Cathode • Dip Package
- 3 to 5 volts @ 5 mils per segment
- 7 segment Monolithic • Red Display

2 Digit	\$.79
3 Digit	.89
4 Digit	1.19
5 Digit	1.99

IC SOLDERTAIL — LOW PROFILE (TIN) SOCKETS

Pin Count	Price	Pin Count	Price
8 pin	\$1.24	24 pin	\$3.38
9 pin	\$1.17	28 pin	\$4.44
12 pin	\$1.21	36 pin	\$6.59
16 pin	\$2.21	40 pin	\$3.62
18 pin	\$2.29	28 pin	\$3.99
22 pin	\$3.37	35 pin	\$3.99
14 pin	\$2.27	25 pin	\$3.99
16 pin	\$2.27	26 pin	\$3.99
18 pin	\$3.37	30 pin	\$3.99
24 pin	\$4.49	42 pin	\$5.99

SOLDERTAIL STANDARD (TIN)

Pin Count	Price	Pin Count	Price
8 pin	\$3.00	24 pin	\$7.00
9 pin	\$3.00	28 pin	\$11.00
12 pin	\$3.37	36 pin	\$17.00
16 pin	\$3.37	40 pin	\$17.00
18 pin	\$4.49	42 pin	\$17.00

SOLDERTAIL STANDARD (GOLD)

Pin Count	Price	Pin Count	Price
8 pin	\$3.00	24 pin	\$7.00
9 pin	\$3.00	28 pin	\$11.00
12 pin	\$3.37	36 pin	\$17.00
16 pin	\$3.37	40 pin	\$17.00
18 pin	\$4.49	42 pin	\$17.00

WIRE WRAP SOCKETS (GOLD) LEVEL #3

Pin Count	Price	Pin Count	Price
8 pin	\$4.45	24 pin	\$10.05
14 pin	\$9.39	28 pin	\$14.00
16 pin	\$9.39	36 pin	\$19.00
18 pin	\$7.86	40 pin	\$19.00

50 PCS. RESISTOR ASSORTMENTS \$1.25 PER ASST.

ASST.	Resistor Values	Price
ASST. 1	10 OHM 12 OHM 15 OHM 18 OHM 22 OHM 27 OHM 33 OHM 39 OHM 47 OHM 56 OHM	1/4 WATT 5% — 50 PCS.
ASST. 2	10 OHM 12 OHM 15 OHM 18 OHM 22 OHM 27 OHM 33 OHM 39 OHM 47 OHM 56 OHM 68 OHM 82 OHM 100 OHM 120 OHM 150 OHM	1/4 WATT 5% — 50 PCS.
ASST. 3	10 OHM 12 OHM 15 OHM 18 OHM 22 OHM 27 OHM 33 OHM 39 OHM 47 OHM 56 OHM 68 OHM 82 OHM 100 OHM 120 OHM 150 OHM 180 OHM 220 OHM 270 OHM 330 OHM 390 OHM	1/4 WATT 5% — 50 PCS.
ASST. 4	10 OHM 12 OHM 15 OHM 18 OHM 22 OHM 27 OHM 33 OHM 39 OHM 47 OHM 56 OHM 68 OHM 82 OHM 100 OHM 120 OHM 150 OHM 180 OHM 220 OHM 270 OHM 330 OHM 390 OHM 470 OHM	1/4 WATT 5% — 50 PCS.
ASST. 5	10 OHM 12 OHM 15 OHM 18 OHM 22 OHM 27 OHM 33 OHM 39 OHM 47 OHM 56 OHM 68 OHM 82 OHM 100 OHM 120 OHM 150 OHM 180 OHM 220 OHM 270 OHM 330 OHM 390 OHM 470 OHM 560 OHM 680 OHM 820 OHM 1K	1/4 WATT 5% — 50 PCS.
ASST. 6	10 OHM 12 OHM 15 OHM 18 OHM 22 OHM 27 OHM 33 OHM 39 OHM 47 OHM 56 OHM 68 OHM 82 OHM 100 OHM 120 OHM 150 OHM 180 OHM 220 OHM 270 OHM 330 OHM 390 OHM 470 OHM 560 OHM 680 OHM 820 OHM 1K 1.2K 1.5K 1.8K 2.2K 2.7	

PLANNING TO MOVE?

Let us know 8 weeks in advance so that you won't miss a single issue of POPULAR ELECTRONICS. Attach old label where indicated and print new address in space provided. Also include your mailing label whenever you write concerning your subscription. It helps us serve you promptly.

Write to: P.O. Box 2774, Boulder, CO 80322 giving the following information:

Change address only Extend my subscription

ENTER NEW SUBSCRIPTION

1 year \$12.00 Payment enclosed (1 extra BONUS issue)
Allow 30-60 days for delivery. Bill me later

AFFIX OLD LABEL →
If you have no label handy, print OLD address here.

Name _____ please print
Address _____
City _____
State _____ Zip _____

NEW ADDRESS HERE 02 10

Name _____ please print
Address _____ Apt. _____
City _____
State _____ Zip _____
Additional postage on foreign orders: add \$3 a year for Canada, \$5 a year for all other countries outside the U.S. and its possessions. Cash only on foreign orders, payable in U.S. currency.

PLANS AND KITS

AMAZING ELECTRONIC PRODUCTS

LASERS SUPER POWERED, RIFLE, PISTOL, POCKET - SEE IN DARK - PYRO-TECHNICAL, DE-BUGGING - UNCRAMBLERS - GIANT TESLA - STUNWAND - TV DISRUPTOR - ENERGY PRODUCING SCIENTIFIC DETECTION, ELECTRIFYING, CHEMICAL, ULTRASONIC, CB, AERO, AUTO AND MECH DEVICES, HUNDREDS MORE - ALL NEW PLUS INFO UNLTD PARTS SERVICE.

INFORMATION unlimited
CATALOG \$1 Box 626 Lode Jeffery PZ • Amherst, N.H. 03031

FREE KIT Catalog contains Test and Experimenter's Equipment, Dage Scientific Instruments, Box 1054P, Livermore, CA 94550.

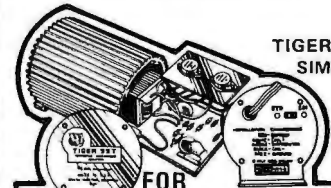

TIGER SST SIMPLI-KIT

FOR THE DO-IT-YOURSELFER

NOW! a high quality CD Electronic Ignition System in kit form.

Contains all components and solder to build complete Solid-State Electronic CD Ignition System for your car. Assembly requires less than 3 hours.

- Increases MPG 15%
- Increases horsepower 15%
- Eliminates 4 of 5 tune-ups
- Instant starting, any weather
- Plugs and Points last 50,000 miles
- Dual system switch

Fits only 12 volt neg. ground... Only \$21.95 postpaid

Tri-Star Corporation
P.O. Box 1727 Grand Junction, Colorado 81501

POCKET COLOR/BAR GENERATOR kit, 16 patterns, \$49.95. Plans, \$4.95. Workshop, Box 393PE, Bethpage, New York 11714.

SCA-ADAPTER kit for FM radio. See Poptronics October 1974. For experienced builders. \$13.50 postpaid. Communications Poly Services, Box 3251C, Westford, Mass. 01886.

SMOKE/GAS ALARM Kit, with plug-in transformer, \$19.95. Romar Systems, 85-76th Street, Brooklyn, New York 11209.

THE "KING OF KITS". Artisan Organ Kits feature all new modular construction, with logic-controlled stops and RAM Preset Memory System. Write for brochure to: AOK Manufacturing, Inc., P.O. Box 445, Kenmore, WA 98028.

FREQUENCY COUNTER: 30/300 MHz, miniportable 2"x4"x4-1/2", 7 digit, .0001% accuracy, internal batteries/external 8-15 vdc. Construction plans, \$5.00 - Complete kit, \$119.95 - Wired and tested, \$149.95. Wilson Products, Box 5516-AI, Walnut Creek, CA 94596.

HIGH FIDELITY

DIAMOND NEEDLES and Stereo Cartridges at Discount prices for Shure, Pickering, Stanton, Empire, Grado and ADC. Send for free catalog. LYLE CARTRIDGES, Dept. P, Box 89, Kensington Station, Brooklyn, New York 11218.

TUBES

RADIO & T.V. Tubes—36 cents each. Send for free Catalog, Cornell, 4213 University, San Diego, Calif. 92105.

TUBES receiving, factory boxed, low prices, free price list. Translateronic, Inc., 1385 39th Street, Brooklyn, N.Y. 11218A, Telephone: 212-633-2800.

TUBES: "Oldies". Latest. Supplies, components, schematics. Catalog Free (stamp appreciated). Steinmetz, 7519-PE Maplewood, Hammond, Ind. 46324.

HYPNOTISM

SLEEP learning. Hypnotic method. 92% effective. Details free. ASR Foundation, Box 23429EG, Fort Lauderdale, Florida 33307.

FREE Hypnotism. Self-Hypnosis. Sleep Learning Catalog! Drawer H400, Ruidoso, New Mexico 88345.

AMAZING self-hypnosis record releases fantastic mental power. Instant results! Free trial. Write: Forum (AA9), 333 North Michigan, Chicago 60601.

INTERNATIONAL ELECTRONICS UNLIMITED

10% OFF WITH \$25 ORDER
15% OFF WITH \$100 ORDER

THESE DISCOUNTS APPLY TO TOTAL OF ORDER - SPECIALS INCLUDED

LED DISPLAYS

DL10A	RED CA. 27" LHD	EA.
DL 707	RED CA. 30" RHD	1.40
DL 807	RED CA. 30" RHD	1.40
FND 359	RED CC. 75" RHD	1.40
DL 702	RED CC. 30" LHD	1.40
NSM 74R	RED CC. 30" RHD	1.40
DL 500	RED CC. 50" RHD	1.40
MAN3	GREEN CA. 27" LHD	1.30
MAN5	YELLOW CA. 27" LHD	1.30
MAN82	YELLOW CA. 3" LHD	1.80
MAN66	RED CA. 6" LHD	2.10
DL747	RED CA. 6" LHD	2.30

LINEAR CIRCUITS

300	\$.71	373	2.42	723	.62
301	.29	376	.68	733	.89
302	.53	380	1.30	739	1.07
304	.80	380-8	1.25	741	.32
305	.71	381	1.75	747	.71
307	.26	382	1.75	748	.35
308	.89	531	2.45	1458	.62
309K	1.35	540	2.95	1800	2.48
310	1.07	550	.79	3900	.49
311	.95	555	.45	7524	.71
1201	1.13	566A	1.19	7525	.90
1202	1.39	560	3.39	8038	4.25
1206	1.39	562	3.39	8864	2.25
122	1.70	565	1.18	75150	1.75
124	1.52	566	1.95	75451	.35
339	1.58	567	1.95	75452	.35
340K	1.69	709	.35	75453	.35
340T	1.49	710	.35	75491	.71
372	2.93	711	.26	75492	.80

SPECIAL DEVICES

372	AF-IF Strip Detector DIP	2.93
546	AM Radio Receiver Subsystem DIP	.75
1310	FM Stereo Demodulator DIP	2.90
1496	Balanced Modulator-Demodulator Stereo multiplexer DIP	2.48
1800	FM Gain Block 34db (typ) mDIP	1.18
ULN228	FM Gain Block 48db (typ) mDIP	1.35
ULN229	FM Gain Block 48db (typ) mDIP	1.35
2513	Character Generator 64x85 DIP-24	10.20
3046	Transistor Array DIP-14	.73

7400	.13	7451	.17	74153	.89
7401	.16	7453	.17	74154	1.20
7402	.15	7454	.17	74155	.97
7403	.15	7460	.17	74156	.97
7404	.16	7464	.35	74157	.99
7405	.19	7465	.35	74158	1.79
7406	.26	7470	.30	74160	1.23
7407	.28	7472	.30	74161	.97
7408	.29	7473	.35	74162	1.29
7409	.19	7474	.28	74163	.99
7410	.16	7475	.49	74164	.99
7411	.25	7476	.30	74165	.99
7413	.43	7483	.68	74166	1.25
7414	.65	7485	.88	74170	2.10
7416	.35	7486	.40	74173	1.49
7417	.35	7489	2.25	74174	1.23
7420	.16	7490	.43	74175	.97
7422	.30	7491	.75	74176	.89
7423	.29	7492	.48	74177	.84
7425	.27	7493	.48	74180	.90
7426	.26	7494	.78	74181	2.45
7427	.29	7495	.79	74182	.79
7430	.20	7496	.79	74184	1.90
7432	.23	74100	.98	74185	2.20
7437	.25	74105	.44	74187	5.75
7438	.25	74107	.37	74190	1.15
7440	.15	74121	.38	74191	1.25
7441	.89	74122	.38	74194	.95
7442	.59	74123	.65	74193	.85
7443	.73	74125	.54	74194	1.25
7444	.73	74126	.58	74195	.74
7445	.73	74132	.89	74916	1.25
7446	.81	74141	1.04	74197	.73
7447	.79	74145	1.04	74198	1.73
7448	.79	74150	.97	74199	1.69
7450	.17	74151	.79	74200	5.45

IC SOCKETS	
Solder Tall - low profile	
8 pin	\$.17 24 pin .42
14 pin	.20 28 pin .59
16 pin	.22 40 pin .69
18 pin	.29

Date sheets on request. Add 30c each if item is priced below \$1.00 each.

MEMORIES

1101	\$.69
1103	.69
1702A	5.95
5262	.99
74S200	3.25
82S23	2.75
93410	1.39

SPECIALS

LINEAR	
301	mDIP .19
723	.49
733	TO-5 .59
380-8	mDIP 1.09
565	1.49
739	.89
75491	mDIP .59
75150	.99

LED DISPLAYS

DLIOA	\$1.49
NSN 74R	.99
FND 359	.59

DISCRETE LEDs

MVIOB	6/\$1.00
MV50	16/\$1.00
MINI RED	
RL 209	12/\$1.00

2708 \$16.95
1 x 8K EROM

7410	Triple 3 input NAND gate	.12
7438	Quad 2 input NAND buffer (o.c.)	.17
7442	BCD to decimal decoder	.39
7453	Exp. AND-OR-INVERT gate	.14
7474	Dual D flip-flop	.19
7493	4 Bit binary counter	.35
74121	One shot	.29
74153	Dual four-input multiplexer	.69



4 Digit Clock Kit
MM5312 and 4 NS1 27" displays 12-24 hours, 50-60 Hz. One P.C. board accommodates clock, display, and all necessary transistors, resistors, capacitors, diodes, 2 switches, complete instructions and schematics for assembly.

CR4-2 \$10.95
Transformer
117 VAC - 12V 300 ma wall mount **\$4.95**

UART AYS1013A \$6.95

CENTRAL PROCESSING UNIT
8008 \$16.95
8080A \$16.95

MM 5330 \$6.95
4 1/2 DIGIT DVM LOGIC

LH 0070 \$6.95
BCD BUFFERED REF.

MM 5616 \$1.25
QUAD BI-LATERAL SWITCH

Carbon Film ± 5%
1/4 WATT 04255
1/2 WATT 04505
2200 resistors 44 values supplied in a 15 drawer
60 compartment storage cabinet - table or wall mount. Ready to use.

1.5	47	470	3.9K	33K	150K	1.0M
3.3	68	680	4.7K	39K	220K	1.5M
6.8	100	1.0K	6.8K	47K	330K	2.2M
10	150	1.5K	10K	68K	470K	3.3M
15	220	2.2K	15K	100K	680K	4.7M
22	270	2.7K	22K			
36	330	3.3K	27K			

MM5309 Divider mDIP \$2.35
Crystal 3.58 MHz color TV \$1.50

CARBON FILM RESISTORS ±5% ALL STANDARD VALUES

QTY.	PRICE (each)	PRICE (Minimum 10 per value)
0-10	\$1.00 ea	
10-100	\$1.00 ea	\$.05 ea
100-1000		\$.04 ea

METAL FILM RESISTORS ALL STANDARD VALUES ±1% ± 1/2 WATT

QTY	PRICE EACH	PRICE MINIMUM 10 PER VALUE	PRICE MINIMUM 100 PER VALUE
0 - 10	\$2.00		
10 - 100	.20	\$.15	
100 - 1000		.10	\$.09
1000 -		.10	.08

TANTALUM CAPACITORS Solid dipped ±20%

.1 mfd	35V	\$.25	10 mfd	16V	\$.40
.33 mfd	35V	\$.25	10 mfd	25V	\$.45
1 mfd	35V	.25	15 mfd	10V	.40
2.2 mfd	20V	.25	15 mfd	20V	.40
2.2 mfd	35V	.30	22 mfd	16V	.45
3.3 mfd	35V	.30	33 mfd	10V	.40
4.7 mfd	16V	.30	47 mfd	6V	.40
6.8 mfd	6V	.30	56 mfd	6V	.45
6.8 mfd	50V	.40	150 mfd	15V	.50

RESISTOR KIT \$59.00
SHIPPING CHG \$2.00

RESISTOR ASSORTMENT 50 RESISTORS PER VALUE

FREE CATALOG AVAILABLE ON REQUEST

Satisfaction guaranteed. Shipment will be made postage prepaid within 3 days from receipt of order. Payment may be made with personal check, charge card (include number and exp. date), or money order. Phone Orders - BoIA and M/C card or C.O.D.

Add \$1.00 to cover shipping and handling if order is less than \$10.00. California residents add sales tax. Include shipping expense for orders shipped out of U.S. and Canada approx. 10% of order.

INTERNATIONAL ELECTRONICS UNLIMITED
VILLAGE SQUARE, P.O. BOX 449
CARMEL VALLEY, CA 93924 USA
PHONE (408) 659-3171

DIGI-KEY CORPORATION

Quality Electronic Components

DON'T FORGET OUR DISCOUNTS WHEN COMPARING PRICES

MICROPROCESSORS

Best Values Yet!

8080A	8-BIT CPU, 2 USEC CYCLE	\$12.95
8212	8-BIT I/O PORT	\$ 3.95
8216	BI-DIRECTIONAL BUS DRIVER	\$ 4.25
8224	CLOCK GENERATOR	\$ 3.95
8228	SYSTEM CONTROLLER	\$ 6.95
8251	COMMUNICATIONS INTERFACE	\$12.95
8255	PERIPHERAL INTERFACE	\$11.95
1702A	2K EPROM (256x8)	\$ 6.95
2708	8K EPROM (1Kx8)	\$29.50
2102-1	1K RAM 500 NS	\$ 1.79
SC/MP	5 VOLT SC/MP CPU	\$ 9.95
2650	MICROPROCESSOR 1.25 MH-2 CLOCK 40 DIL.	\$24.95

8080A CHIP SET

ONE EACH 8080A, 8212, 8224 and 8228 PLUS SIXTEEN 2102-1's — ALL FOR

\$49.95

PRICE BREAKTHROUGH ON 74LS*

74LS00	28	74LS00	28	74LS90	57	74LS157	75	74LS248	79
74LS01	28	74LS37	33	74LS91	23	74LS158	75	74LS249	79
74LS02	28	74LS38	33	74LS92	57	74LS159	102	74LS250	84
74LS03	28	74LS39	33	74LS93	39	74LS160	102	74LS251	84
74LS04	28	74LS40	28	74LS94	39	74LS161	102	74LS252	84
74LS05	28	74LS41	28	74LS95	39	74LS162	102	74LS253	84
74LS06	28	74LS42	28	74LS96	67	74LS163	102	74LS254	84
74LS07	28	74LS43	28	74LS97	67	74LS164	102	74LS255	84
74LS08	28	74LS44	28	74LS98	67	74LS165	102	74LS256	84
74LS09	28	74LS45	28	74LS99	67	74LS166	114	74LS257	84
74LS10	28	74LS46	28	74LS100	39	74LS167	114	74LS258	84
74LS11	28	74LS47	28	74LS101	39	74LS168	114	74LS259	84
74LS12	28	74LS48	28	74LS102	39	74LS169	114	74LS260	84
74LS13	28	74LS49	28	74LS103	39	74LS170	123	74LS261	84
74LS14	28	74LS50	28	74LS104	39	74LS171	123	74LS262	84
74LS15	28	74LS51	28	74LS105	39	74LS172	123	74LS263	84
74LS16	28	74LS52	28	74LS106	39	74LS173	123	74LS264	84
74LS17	28	74LS53	28	74LS107	39	74LS174	134	74LS265	84
74LS18	28	74LS54	28	74LS108	39	74LS175	134	74LS266	84
74LS19	28	74LS55	28	74LS109	39	74LS176	134	74LS267	84
74LS20	28	74LS56	28	74LS110	39	74LS177	134	74LS268	84
74LS21	28	74LS57	28	74LS111	39	74LS178	134	74LS269	84
74LS22	28	74LS58	28	74LS112	39	74LS179	134	74LS270	84
74LS23	28	74LS59	28	74LS113	39	74LS180	134	74LS271	84
74LS24	28	74LS60	28	74LS114	39	74LS181	134	74LS272	84
74LS25	28	74LS61	28	74LS115	39	74LS182	134	74LS273	84
74LS26	28	74LS62	28	74LS116	39	74LS183	134	74LS274	84
74LS27	28	74LS63	28	74LS117	39	74LS184	134	74LS275	84
74LS28	28	74LS64	28	74LS118	39	74LS185	134	74LS276	84
74LS29	28	74LS65	28	74LS119	39	74LS186	134	74LS277	84
74LS30	28	74LS66	28	74LS120	39	74LS187	134	74LS278	84
74LS31	28	74LS67	28	74LS121	39	74LS188	134	74LS279	84
74LS32	28	74LS68	28	74LS122	39	74LS189	134	74LS280	84
74LS33	28	74LS69	28	74LS123	39	74LS190	134	74LS281	84
74LS34	28	74LS70	28	74LS124	39	74LS191	134	74LS282	84
74LS35	28	74LS71	28	74LS125	39	74LS192	134	74LS283	84
74LS36	28	74LS72	28	74LS126	39	74LS193	134	74LS284	84
74LS37	28	74LS73	28	74LS127	39	74LS194	134	74LS285	84
74LS38	28	74LS74	28	74LS128	39	74LS195	134	74LS286	84
74LS39	28	74LS75	28	74LS129	39	74LS196	134	74LS287	84
74LS40	28	74LS76	28	74LS130	39	74LS197	134	74LS288	84
74LS41	28	74LS77	28	74LS131	39	74LS198	134	74LS289	84
74LS42	28	74LS78	28	74LS132	39	74LS199	134	74LS290	84
74LS43	28	74LS79	28	74LS133	39	74LS200	134	74LS291	84
74LS44	28	74LS80	28	74LS134	39	74LS201	134	74LS292	84
74LS45	28	74LS81	28	74LS135	39	74LS202	134	74LS293	84
74LS46	28	74LS82	28	74LS136	39	74LS203	134	74LS294	84
74LS47	28	74LS83	28	74LS137	39	74LS204	134	74LS295	84
74LS48	28	74LS84	28	74LS138	39	74LS205	134	74LS296	84
74LS49	28	74LS85	28	74LS139	39	74LS206	134	74LS297	84
74LS50	28	74LS86	28	74LS140	39	74LS207	134	74LS298	84
74LS51	28	74LS87	28	74LS141	39	74LS208	134	74LS299	84
74LS52	28	74LS88	28	74LS142	39	74LS209	134	74LS300	84
74LS53	28	74LS89	28	74LS143	39	74LS210	134	74LS301	84
74LS54	28	74LS90	28	74LS144	39	74LS211	134	74LS302	84
74LS55	28	74LS91	28	74LS145	39	74LS212	134	74LS303	84
74LS56	28	74LS92	28	74LS146	39	74LS213	134	74LS304	84
74LS57	28	74LS93	28	74LS147	39	74LS214	134	74LS305	84
74LS58	28	74LS94	28	74LS148	39	74LS215	134	74LS306	84
74LS59	28	74LS95	28	74LS149	39	74LS216	134	74LS307	84
74LS60	28	74LS96	28	74LS150	39	74LS217	134	74LS308	84
74LS61	28	74LS97	28	74LS151	39	74LS218	134	74LS309	84
74LS62	28	74LS98	28	74LS152	39	74LS219	134	74LS310	84
74LS63	28	74LS99	28	74LS153	39	74LS220	134	74LS311	84
74LS64	28	74LS100	28	74LS154	39	74LS221	134	74LS312	84
74LS65	28	74LS101	28	74LS155	39	74LS222	134	74LS313	84
74LS66	28	74LS102	28	74LS156	39	74LS223	134	74LS314	84
74LS67	28	74LS103	28	74LS157	39	74LS224	134	74LS315	84
74LS68	28	74LS104	28	74LS158	39	74LS225	134	74LS316	84
74LS69	28	74LS105	28	74LS159	39	74LS226	134	74LS317	84
74LS70	28	74LS106	28	74LS160	39	74LS227	134	74LS318	84
74LS71	28	74LS107	28	74LS161	39	74LS228	134	74LS319	84
74LS72	28	74LS108	28	74LS162	39	74LS229	134	74LS320	84
74LS73	28	74LS109	28	74LS163	39	74LS230	134	74LS321	84
74LS74	28	74LS110	28	74LS164	39	74LS231	134	74LS322	84
74LS75	28	74LS111	28	74LS165	39	74LS232	134	74LS323	84
74LS76	28	74LS112	28	74LS166	39	74LS233	134	74LS324	84
74LS77	28	74LS113	28	74LS167	39	74LS234	134	74LS325	84
74LS78	28	74LS114	28	74LS168	39	74LS235	134	74LS326	84
74LS79	28	74LS115	28	74LS169	39	74LS236	134	74LS327	84
74LS80	28	74LS116	28	74LS170	39	74LS237	134	74LS328	84
74LS81	28	74LS117	28	74LS171	39	74LS238	134	74LS329	84
74LS82	28	74LS118	28	74LS172	39	74LS239	134	74LS330	84
74LS83	28	74LS119	28	74LS173	39	74LS240	134	74LS331	84
74LS84	28	74LS120	28	74LS174	39	74LS241	134	74LS332	84
74LS85	28	74LS121	28	74LS175	39	74LS242	134	74LS333	84
74LS86	28	74LS122	28	74LS176	39	74LS243	134	74LS334	84
74LS87	28	74LS123	28	74LS177	39	74LS244	134	74LS335	84
74LS88	28	74LS124	28	74LS178	39	74LS245	134	74LS336	84
74LS89	28	74LS125	28	74LS179	39	74LS246	134	74LS337	84
74LS90	28	74LS126	28	74LS180	39	74LS247	134	74LS338	84
74LS91	28	74LS127	28	74LS181	39	74LS248	134	74LS339	84
74LS92	28	74LS128	28	74LS182	39	74LS249	134	74LS340	84
74LS93	28	74LS129	28	74LS183	39	74LS250	134	74LS341	84
74LS94	28	74LS130	28	74LS184	39	74LS251	134	74LS342	84
74LS95	28	74LS131	28	74LS185	39	74LS252	134	74LS343	84
74LS96	28	74LS132	28	74LS186	39	74LS253	134	74LS344	84
74LS97	28	74LS133	28	74LS187	39	74LS254	134	74LS345	84
74LS98	28	74LS134	28	74LS188	39	74LS255	134	74LS346	84
74LS99	28	74LS135	28	74LS189	39	74LS256	134	74LS347	84
74LS100	28	74LS136	28	74LS190	39	74LS257	134	74LS348	84

INTEGRATED CIRCUITS TTL, CMOS, LINEAR

7400	21	7476	37	74181	215	4012	23	4520	114
7401	21	7477	37	74182	215	4013	23	4521	114
7402	21	7478	37	74183	219	4014	96	4522	88
7403	21	7479	37	74184	219	4015	96	4523	88
7404	21	7480	37	74185	219	4016	40	4524	1.25
7405	21	7481	37	74186	219	4017	40	4525	1.25
7406	21	7482	37	74187	219	4018	40	4526	1.25
7407	21	7483	37	74188	219	4019	40	4527	1.25
7408	21	7484	37	74189	219	4020	40	4528	1.25
7409	21	7485	37	74190	223	4021	23	4529	1.25
7410	21	7486	37	74191	223	4022	23	4530	1.25
7411	21	7487	37	74192	223	4023	23	4531	1.25
7412	21	7488	37	74193	223	4024	23	4532	1.25
7413	21	7489	37	74194	223	4025	23	4533	1.25
7414	21	7490	37	74195	223	4026	23	4534	1.25
7415	21	7491	37	74196	223	4027	23	4535	1.25
7416	21	7492	37	74197	223	4028	23	4536	1.25
7417	21	7493	37	74198	223	4029	23	4537	1.25
7418	21	7494	37	74199	223	4030	23	4538	1.25
7419	21	7495	37	74200	223	4031	23	4539	1.25
7420	21	7496	37	74201	223	4032	23	4540	1.25
7421	21	7497	37	74202	223	4033	23	4541	1.25
7422	21	7498	37	74203	223				

MOVIE FILMS

MOVIES FROM: COLUMBIA PICTURES/WARNER BROS. the greatest films in Super 8, sound or silent, "Lawrence of Arabia", "Summer of '42", all your favorites. Send for your free catalog to Columbia Pictures 8mm Films, Dept. PE, 711 Fifth Avenue, New York, New York 10022.

BUSINESS OPPORTUNITIES

I MADE \$40,000.00 Year by Mailorder! Helped others make money! Free Proof. Torrey, Box 318-NN, Ypsilanti, Michigan 48197.

HOW TO MAKE \$2,000 WEEKLY at home using other people's money. Guaranteed. Free Details. Richlieu, Box 25357, Dept. F8, Houston 77005.

NEW LUXURY Car Without Cost. Free Details! Codex-ZZ, Box 6073, Toledo, Ohio 43614.

FREE CATALOGS. Repair air conditioning, refrigeration. Tools, supplies, full instructions. Doolin, 2016 Canton, Dallas, Texas 75201.

MAILORDER MILLIONAIRE helps beginners make \$500 weekly. Free report reveals secret plan! Executive (1K9), 333 North Michigan, Chicago 60601.

GET RICH with Secret Law that smashes debts and brings you \$500 to \$5 Million cash. Free report! Credit 4K9, 333 North Michigan, Chicago 60601.

HIGHLY PROFITABLE ONE-MAN ELECTRONIC FACTORY

Investment unnecessary, knowledge not required, sales handled by professionals. Postcard brings facts about this unusual opportunity. Write today! Barta-DV, Box 248, Walnut Creek, CA 94597.

MECHANICALLY Inclined individuals desiring ownership of Small Electronics Manufacturing Business — without investment. Write: Marks, 92-K9 Brighton 11th, Brooklyn, New York 11235.

\$500 PER DAY POSSIBLE. New C.B. related business. Send 25 cents. P.A. Schubert Company, P.O. Box 187, Howell, Mich. 48843.

BORROW \$25,000 interest-free!! . . . keep indefinitely. Any-one! Free Report. Executive-PE9, Box 368, Buford, Georgia 30518.

INVENTIONS WANTED

INVENTORS: Manufacturers Need New Products. Free "Recommended Procedure," by a creative fee-based invention service company. Washington Inventors Service, 422-T Washington Building, Washington, D. C. 20005.

INVENTORS RECOGNITION... FINANCIAL REWARD... OR CREDIT FOR "INVENTING IT FIRST" MAY BE YOURS!

If you have an idea for a new product, or a way to make an old product better, contact us, "the idea people." We'll develop your idea, introduce it to industry, negotiate for cash sale or royalty licensing. Write now without cost or obligation for free information. Fees are charged only for contracted services. So send for your FREE "Inventor's Kit." It has important Marketing Information, a special "Invention Record Form" and a Directory of 1001 Corporations Seeking New Products.

RAYMOND LEE ORGANIZATION
230 Park Avenue North, New York, NY 10017

At no cost or obligation, please rush my FREE "Inventor's Kit No. A-112"

Name _____
Address _____
City _____ State _____ Zip _____
Phone No. _____ Area Code _____

FREE PAMPHLET: "Tips on Marketing Your Invention", from an experienced fee-based invention service company. Write: United States Inventors Service Company, Dept. T, 1435 G Street NW, Washington DC 20005.

The J.M.J. DIGITAL DISPLAY BEZEL FOR APPEARANCE AND PERFORMANCE!

Now you can add a truly professional appearance to your digital projects and improve their performance as well. . . With the JMJ BEZEL. It will vastly improve the readability of the display and put a finishing touch on any front panel. And that's important, for obviously, the display is the most looked-at feature on any piece of digital equipment.



\$4.95 EACH
(Please order by color)

UNIVERSAL SIZE HANDLES MOST REQUIREMENTS

PATENTED CHROMAFILTER® SCREEN

- Eliminates glare and reflections
 - Improves contrast and readability
 - Scratch resistant — easily cleaned
 - Out-performs circular polarized types
 - Available in four colors
- DIE CAST METAL FRAME**
- Nonreflective black finish
 - Durable — heat resistant
 - Integral 6-32 mounting studs
 - No exposed hardware
 - Mounts in panels up to 3/16" thick
 - Includes all hardware and a special template for easy installation.

© Panelgraphic Corp., W. Caldwell, N.J.

DEALERS INQUIRIES INVITED

ATTENTION CLOCK BUILDERS

Adapters for mounting clock modules and clock displays directly to the JMJ-BEZEL. Assures perfect alignment and simplifies mounting (Please Order by Number).

\$.69 ea.

ADAPTER #1 (Fits the following)

National	Liton	Texas Inst.	Bowmar
MA 1001	LT 601	TIL 364	Opti-Stick
MA 1002	LT 442	thru	
NSB5917	LT 446	TIL 372	
NSB5921	LT 447		
NSB5922			

ADAPTER #2 (Fits the following)

National	Liton
MA 1010	LT 701
MA 1012	
MA 1013	

ADAPTER-3 (Universal Mount) For mounting any PC Board to the JMJ-BEZEL (Requires two mounting holes in PC Board).

TERMS: Minimum Order \$4 95
Add \$1 00 for Postage & Handling
N J Residents Add 5% Sales Tax
Send Check or M O — No COD s

NAME		
ADDRESS		
CITY	STATE	ZIP
J.M.J. BEZELS at \$4.95 EA. (COLOR: _____)		
ADAPTERS at \$.69 EA. (NUMBER: _____)		
POSTAGE & HANDLING		1.00
5% N.J. SALES TAX		
AMOUNT ENCLOSED		
J.M.J. TECHNICAL PRODUCTS, INC. BOX 26, KENDALL PARK, N.J. 08824		

FREE

BA's 1978 ANNUAL CATALOG!

260 PAGE RADIO, TV & ELECTRONIC CATALOG

BA THE WORLD'S MOST COMPLETE CATALOG OF EVERYTHING IN ELECTRONICS

WRITE FOR YOUR FREE COPY NOW!

Your buying guide for Everything in Electronics... Stereo, Hi-Fi, TVs, Radios, Tape Recorders, CB, Kits, Tools, Books and Electronic parts.

BURSTEIN-APPLEBEE
Dept. PE-9 3199 MERCIER
KANSAS CITY, MO. 64111

NAME _____
ADDRESS _____
CITY _____
STATE _____ ZIP _____

INSTRUCTION

LEARN ELECTRONIC ORGAN SERVICING at home all makes including transistor. Experimental kit—trouble-shooting. Accredited NHSC, Free Booklet. NILES BRYANT SCHOOL, 3631 Stockton, Dept. A, Sacramento, Calif. 95820.

SCORE high on F.C.C. Exams... Over 300 questions and answers. Covers 3rd, 2nd, 1st and even Radar. Third and Second Test, \$14.50; First Class Test, \$15.00. All tests, \$26.50. R.E.I., Inc., Box 806, Sarasota, Fla. 33577.

UNIVERSITY DEGREES BY MAIL! Bachelors, Masters, Ph.D's. Free revealing details. Counseling, Box 317-PE9, Tustin, California 92680.

SELF-STUDY CB RADIO REPAIR COURSE. THERE'S MONEY TO BE MADE REPAIRING CB RADIOS. This easy-to-learn course can prepare you for a career in electronics enabling you to earn as much as \$16.00 an hour in your spare time. For more information write: CB RADIO REPAIR COURSE, Dept. PE09, 531 N. Ann Arbor, Okla. City, Okla. 73127.

LEARN WHILE ASLEEP! HYPNOTIZE! Astonishing details, strange catalog free! Autosuggestion, Box 24-ZD, Olympia, Washington 98507.

GRANTHAM'S FCC LICENSE STUDY GUIDE — 377 pages, 1465 questions with answers/discussions — covering third, second, first radiotelephone examinations. \$13.45 postpaid. GSE, P.O. Box 25992, Los Angeles, California 90025.

INTENSIVE 5 week course for Broadcast Engineers. FCC First Class license. Student rooms at the school. Radio Engineering Inc., 61 N. Pineapple Ave., Sarasota, FL 33577 and 2402 Tidewater Trail, Fredericksburg, VA 22401.

HIGHLY EFFECTIVE Degree Program in Electronics Engineering. Advance rapidly! Our 31st Year. Free literature. Cook's Institute, Box 20345, Jackson, Miss. 39209.

1977 TESTS-ANSWERS for FCC First Class License. Plus "Self-Study Ability Test." Proven! \$9.95. Moneyback Guarantee. "FREE" BROCHURE. Command, Box 26348-P, San Francisco 94126.

GET your Commercial FCC License. New Exams by author of successful published workbooks of FCC Practice Tests. 500 Questions Second Class, \$11.95; 200 First Class, \$7.95; 100 Radar, \$4.95; Postpaid. Save, all three \$19.95. Complete mathematical solutions. Free counselling service. Victor Veley, P.O. Box 14, La Verne, Calif. 91750.

RADIO BROADCASTING: Become a DJ-engineer, start your own station, receive free tapes-records. Learn details free. "Broadcasting", Box 5516-AI, Walnut Creek, CA 94596.

TAPE AND RECORDERS

RENT 4-Track open reel tapes—free brochure. Stereo-Parti, P.O. Box 7, Fulton, CA 95401.

8-TRACK and CASSETTE BELTS — money back guarantee. Long wearing. Free Catalog — \$3 minimum order. PRB Corp., Box 176, Whitewater, Wisconsin 53190.

GOVERNMENT SURPLUS

MANUALS for Govt Surplus radios, test sets, scopes. List 50 cents (coin). Books, 7218 Roanne Drive, Washington, D.C. 20021.

GOVERNMENT SURPLUS. Buy in your Area. How, where. Send \$2.00. Surplus, 30177-PE Headquarters Building, Washington, D.C. 20014.

JEEPS, TRUCKS, Typically from \$52.40... Automobiles, Boats, Motorcycles, Airplanes, Oscilloscopes, Tools, Clothing, Sports, Camping, Photographic, Electronics Equipment... 200,000 Bid Bargains Nationwide Direct from Government... Low as 2 cents on Dollar! Surplus Catalog and Sales Directory \$1.00 (refundable). National Surplus Center, 240 Eastcass-PEL, Joliet, Illinois 60432.

PERSONALS

MAKE FRIENDS WORLDWIDE through international correspondence. Illustrated brochure free. Hermes-Verlag, Box 110660/Z, D-1000 Berlin 11, Germany.

MUSICAL INSTRUMENTS

UP TO 60% DISCOUNT. Name brand instruments catalog. Freeport Music, 114 G. Mahan St., W. Babylon, N.Y. 11704.

HOME ENTERTAINMENT FILMS

EVERYBODY LOVES MOVIES! Order these Alfred Hitchcock thriller specials. "Frenzy" or "Psycho" 200' Super 8 silent \$7.95 ea — Super 8-mag sound, \$16.95 ea ppd (you save \$2.00). Or 400' S-8 color-sound "Frenzy" or "The Birds" only \$45.95 ea ppd. Or "Psycho" S-8 B&W sound \$35.95 ppd (you save \$5.00 per print incl. postage). Comedy gala Abbott & Costello "In Society" and A&C meet the "Key Stone Kops". Universal Super 8 B&W-sound \$35.95 ea ppd. Also Marx Brothers in "Monkey Business". Limited Offer. Reserve Right to limit quantity. Send for Columbia catalog, \$0.85; Universal 8 catalog, \$0.75; Sportlite forms, \$0.35. SPORTLITE, Elect-9, 20 N. Wacker Dr., Chicago, IL 60606.

RUBBER STAMPS

RUBBER STAMPS, BUSINESS CARDS. Many new products. Catalog, Jackson's, Dept. K, Brownsville Rd., Mt. Vernon, Ill. 62864.

REAL ESTATE

BIG...FREE...FALL CATALOG! Over 2,500 top values coast to coast! UNITED FARM AGENCY, 612-EP, West 47th, Kansas City, MO 64112.

EMPLOYMENT OPPORTUNITIES

ELECTRONICS/AVIONICS EMPLOYMENT OPPORTUNITIES. Report on jobs now open. Details FREE. Aviation Employment Information Service, Box 240E, Northport, New York 11768.

TREASURE FINDERS

SERIOUS COIN SHOOTERS — Semtech's solid-state METL-SENSOR pin-points ALL metal objects, yet defines the target before you dig. FOR FREE literature write Semtech Corporation, 652 Mitchell Rd., Newbury Park, Calif. 91320.

E

NEW LSI TECHNOLOGY

FREQUENCY COUNTER

TAKE ADVANTAGE OF THIS NEW STATE-OF-THE-ART COUNTER FEATURING THE MANY BENEFITS OF CUSTOM LSI CIRCUITRY. THIS NEW TECHNOLOGY APPROACH TO INSTRUMENTATION YIELDS ENHANCED PERFORMANCE, SMALLER PHYSICAL SIZE, DRASTICALLY REDUCED POWER CONSUMPTION [PORTABLE BATTERY OPERATION IS NOW PRACTICAL], DEPENDABILITY, EASY ASSEMBLY AND REVOLUTIONARY LOWER PRICING!

SIZE:
3" High
6" Wide
5 1/2" Deep

1 3/4 LBS.
COLOR:
BLACK

FEATURES AND SPECIFICATIONS:

DISPLAY: 8 RED LED DIGITS .4" CHARACTER HEIGHT
GATE TIMES: 1 SECOND AND 1/10 SECOND [AUTO DEC. PT. PLACEMENT]
RESOLUTION: 1 HZ AT 1 SECOND, 10 HZ AT 1/10 SECOND.
FREQUENCY RANGE: 10 HZ TO 60 MHZ. [65 MHZ TYPICAL].
SENSITIVITY: 10 MV RMS TO 50 MHZ, 20 MV RMS TO 60 MHZ TYP.
INPUT IMPEDANCE: 1 MEGOHM AND 20 PF.
[DIODE PROTECTED INPUT FOR OVER VOLTAGE PROTECTION.]
ACCURACY: ± 1 PPM [± .0001%]; AFTER CALIBRATION TYPICAL.
STABILITY: WITHIN 1 PPM PER HOUR AFTER WARM UP [.001% XTAL]
IC PACKAGE COUNT: 8 [ALL SOCKETED]
INTERNAL POWER SUPPLY: 5.2 V DC AT 800 MA. REGULATED.
INPUT POWER REQUIRED: 8-12 VDC OR 115 VAC AT 50/60 HZ.
POWER CONSUMPTION: 4 WATTS
INPUT CONNECTOR: BNC TYPE

**ORDER BY PHONE OR MAIL
COD ORDERS WELCOME**

KIT #FC-50C	60 MHZ COUNTER WITH CABINET & P.S.	\$119.95
KIT #PSL-350	350 MHZ PRESCALER [NOT SHOWN]	23.95
KIT #PSL-650	650 MHZ PRESCALER [NOT SHOWN]	29.95
MODEL #FC-50WT	60 MHZ COUNTER WIRED, TESTED & CAL.	165.95
MODEL #FC-50/600 WT.	600 MHZ COUNTER WIRED, TESTED & CAL.	199.95

KIT #FC-50C IS COMPLETE WITH PREDRILLED CHASSIS ALL HARDWARE AND STEP-BY-STEP INSTRUCTIONS. WIRED & TESTED UNITS ARE CALIBRATED AND GUARANTEED. PRESCALERS WILL FIT INSIDE COUNTER CABINET.

TERMS: FOR SHIPPING, HANDLING & INSURANCE TO US & CANADA ADD 5% ALL OTHERS 10%. FLORIDA RES. ADD 4% SALES TAX. COD CHARGE \$1.00.

E

OPTOELECTRONICS, INC.

BOX 219 • HOLLYWOOD, FLA. 33022 • (305) 921-2056

master charge

BANKAMERICARD

visa

CIRCLE NO. 45 ON FREE INFORMATION CARD

E-Z-HOOK

E-Z Hooks have been designed and field tested through the industry to save time and money in commercial electronic production and servicing. The spring-loaded hook attaches firmly, yet so gently it will not damage component - frees hands while testing. Durably constructed and fully insulated to a single contact point assuring true readings. Meets exacting laboratory and space age computer technology requirements. AVAILABLE IN 10 RETMA COLORS: Red, black, blue, green, orange, yellow, white, violet, brown or gray.

MICRO HOOK

XM Micro Hook (1.75" long <1 gram) for difficult IC Testing. Permits hookups to delicate wires where weight and leverage may damage component. \$1.70
Specify color. ORDER P/N XM

Jumper with XM Micro Hooks

Order No. Length Price
204XM-12" 12" \$1.70
204XM-24" 24" 1.70
Specify color.

XM-S MICRO HOOK SET (Includes 1 ea. red, black, blue, green, orange, yellow, white, brown, violet and gray Micro Hook). At this low price you can afford more than one set.
COMPLETE SET (10) MICRO HOOKS \$7.95

MINI HOOK

X100W Mini Hook (2.25" long) combines rugged construction, miniature size and Finger-Size Myco Action for all the best test connections. Hook is large enough for component leads, yet small enough to get into tight places. \$7.95 ea.
Specify color. ORDER P/N X100W

Jumper with X-100W Mini Hooks

Order No. Length Price
204-12W 12" \$1.60
204-24W 24" 1.60
Specify color.

Jumper X-100W Mini Hook to Stacking Banana Plug

Order No. Length Price
201W 32" \$1.35
Specify color.

Jumper with X-100W Mini Hook

Order No. Length Price
201XM 32" \$1.40

EXTRA LONG MINI HOOK

XL-1 Mini Hook (5.0" long) combines all the proven features of the X100W with an extra long body. It will make safe, short-free test connections in card racks and through deep wiring nest up to 4" . . . ORDER P/N XL-1

Specify color. \$1.25

JUMPER, XL-1 MINI HOOK TO STACKING BANANA PLUG

Order No. Length Price
201XL-1 32" \$1.95
Specify color.

Order No. Length Price
201XM 32" \$1.40



ANACRON

Our Quality Is Best!



**QUITE PORTABLE
VERY AFFORDABLE
AND UNBELIEVABLY
VERSATILE**
the PET computer may very well be a lifetime investment

PET MODEL 2001

SPECIFICATIONS
DIMENSIONS LWD 18-1/2 x 16-1/2 x 14
WEIGHT 44 lbs
BASIC Interpreter
ROM (user) 4K (8K OPT.) exp to 32K
RAM (resident operating system) 14K
RAM (user) 4K
4K Operating system
1K Diagnostic routine
1K Machine language monitor

VIDEO DISPLAY UNIT

8" h/w high resolution CRT + 1000 char display, 40 col by 25 lines - 8 dot matrix for characters and continuous graphics. Auto scrolling from bottom of screen. Winking cursor with full motion control. Reverse field on all characters. 64 standard ASCII char, 64 graphic char.

KEYBOARD

9-1/2" wide x 3" deep, 73 keys. All 64 ASCII characters available without shift. Calculator style numeric key pad. All G4 graphic and reverse field characters accessible from keyboard (with shift). Screen Control. Clear and erase. Editing. Character insertion and deletion.

CASSETTE STORAGE

Fast redundant recording scheme assuring reliable data recovery. Modified drive for higher reliability of recording and control retention. High noise immunity, error detection and correction. Use standard audio cassette tapes. Tape flags marked.

OPERATING SYSTEM

Supports multiple languages. Machine language accessibility. File management in operating system. Cursor control, reverse field and graphics under simple BASIC control. Cassette file management from BASIC. True random number generation or pseudo random sequence.

INPUT/OUTPUT

All other I/O supported through IEEE488 instrument interface which allows for multiple intelligent peripherals. All I/O automatically managed by operating system software. Single character I/O with GET command. Easy screen line-edit capability. Flexible I/O structure allows for BASIC expansion with intelligent peripherals.

BASIC INTERPRETER

Expanded 8K BASIC. Upward expansion from current popular BASIC language. Strings, integers and multi dim arrays. High precision (10 significant digits). Direct memory access through PEEK and POKE commands.

PET MODEL 2001 \$795.00

OPT. 8K RAM ONLY \$795.00



BUILD A WORKING DPM IN 1/2 HOUR WITH THESE COMPLETE EVALUATION KITS.

Test these new parts for yourself with Intersil's low-cost prototyping kits, complete with A/D converter and LCD display (for the 7106) or LED display (for the 7107). Kits provide all materials, including PC board, for a functioning panel meter.

- ICL7106EV (LCD) \$29.95
- ICL7107EV (LED) \$24.95

CAPACITORS

50V CERAMIC DISC \$1.00 Per Package

5p1 9/pkg	300p1 7/pkg	.0047mfd 9/pkg
15p1 9/pkg	330p1 7/pkg	.0051mfd 9/pkg
25p1 9/pkg	390p1 7/pkg	.01mfd 9/pkg
27p1 9/pkg	470p1 7/pkg	.015mfd 8/pkg
47p1 8/pkg	560p1 7/pkg	.02mfd 8/pkg
68p1 8/pkg	680p1 7/pkg	.022mfd 8/pkg
100p1 8/pkg	.001mfd 9/pkg	.03mfd 8/pkg
150p1 8/pkg	.0015mfd 9/pkg	.039mfd 7/pkg
220p1 8/pkg	.0022mfd 9/pkg	.047mfd 7/pkg
270p1 7/pkg	.003mfd 9/pkg	.1mfd 6/pkg

PLESSEY POLYESTER MINI BOX

MF V	S	MF V	S	MF V	S
001	1000	14	.012	630	.14
0012	1000	14	.015	400	.15
0015	1000	14	.018	400	.15
0018	1000	14	.022	400	.15
0022	1000	14	.027	400	.15
0027	1000	14	.033	250	.18
0033	1000	14	.039	250	.18
0039	630	14	.047	250	.18
0047	630	14	.056	250	.18
0056	630	14	.068	250	.18
0068	630	14	.082	250	.17
0082	630	14	.1	100	.17
01	630	14	.12	100	.18

MATSUO DIPPED TANTALUM

MF V	S	MF V	S	MF V	S
1	.35	.33	2.2	.30	10
1.5	.35	.33	2.2	.35	40
2.2	.35	.33	3.3	.45	15
3.3	.35	.33	4.7	.35	45
4.7	.35	.33	6.3	.40	30
6.3	.35	.33	6.8	.35	45
1.0	35	.33	10	.16	42
1.5	35	.40	10	.25	.45

1% MICA 500V

MF V	S	MF V	S	MF V	S
51	PF	29	220	PF	41
62	PF	29	240	PF	46
75	PF	29	300	PF	50
82	PF	29	390	PF	50
100	PF	30	470	PF	50
120	PF	32	620	PF	52
150	PF	35	820	PF	53
180	PF	41	1000	PF	60

ALUMINUM ELECTROLYTIC (RADIAL LEAD)

MF V	S	MF V	S	MF V	S
1	10	12	16	15	33
1	18	12	18	15	33
1	25	14	20	15	33
1	33	16	22	15	33
1	47	18	25	15	33
1	68	20	30	15	33
1	100	22	33	15	33
1	150	25	33	15	33
1	220	25	33	15	33
1	330	25	33	15	33
1	470	25	33	15	33
1	680	25	33	15	33
1	1000	25	33	15	33
1	1500	25	33	15	33
1	2200	25	33	15	33
1	3300	25	33	15	33
1	4700	25	33	15	33
1	6800	25	33	15	33
1	10000	25	33	15	33
1	15000	25	33	15	33
1	22000	25	33	15	33
1	33000	25	33	15	33
1	47000	25	33	15	33
1	68000	25	33	15	33
1	100000	25	33	15	33
1	150000	25	33	15	33
1	220000	25	33	15	33
1	330000	25	33	15	33
1	470000	25	33	15	33
1	680000	25	33	15	33
1	1000000	25	33	15	33
1	1500000	25	33	15	33
1	2200000	25	33	15	33
1	3300000	25	33	15	33
1	4700000	25	33	15	33
1	6800000	25	33	15	33
1	10000000	25	33	15	33
1	15000000	25	33	15	33
1	22000000	25	33	15	33
1	33000000	25	33	15	33
1	47000000	25	33	15	33
1	68000000	25	33	15	33
1	100000000	25	33	15	33

NEW from FLUKE - MODEL 8020A

THE DMM FOR THE PROFESSIONAL

- 200 Hr Battery Life
- 28 Ranges for 7 Functions
- 2000 Count Resolution
- High-Low Power Ohms
- Autozero and Auto-polarity
- MOV-protected to 5000V against hidden transients and overload protection to 300 V AC
- Diode Test Function
- Conductance Function checks leakage resistance to 10,000 meg ohms
- Size: HMM (7.1x3.4x1.8 IN) (18.0x8.6x4.5 cm)
- Weight: 13 oz.

2N TRANSISTORS

2N308A	50	2N3904A	36	2N4036	50	2N4921	60	2N5306	34	2N5824	25
2N697	36	2N2905A	36	2N4037	55	2N4922	100	2N5308	40	2N5825	26
2N699	40	2N2906A	36	2N4060	20	2N4931	1.00	2N5309	50	2N5826	30
2N718	40	2N2907A	28	2N4061	25	2N4934	1.50	2N5321	60	2N5827	34
2N719	40	2N2907A	28	2N4074	10	2N4935	75	2N5322	70	2N5828	40
2N718A	40	2N2907A	28	2N4125	20	2N4931	1.75	2N5323	34	2N6000	30
2N918	40	2N2924	30	2N4126	24	2N4934	30	2N5365	50	2N6002	34
2N929	28	2N3715	20	2N4127	28	2N4934	30	2N5367	50	2N6015	68
2N930	28	2N3725	52	2N4143	18	2N6086	30	2N5368	28	2N6027	50
2N932	28	2N3725	52	2N4226	1.80	2N5089	40	2N5370	28	2N6028	34
2N1613	32	2N3053	36	2N4227	1.80	2N5109	1.90	2N5375	28	2N6037	52
2N1711	34	2N3054	36	2N4237	1.80	2N5131	20	2N5383	28	2N6076	20
2N1620	32	2N3055	36	2N4237	1.80	2N5132	18	2N5387	25	2N6098	80
2N102	40	2N3275	30	2N4248	22	2N5134	20	2N5418	30	2N6101	1.06
2N2160	1.65	2N3391A	22	2N4249	22	2N5134	20	2N5418	30	2N6101	1.06
2N2218	26	2N3392	22	2N4249	22	2N5134	20	2N5418	30	2N6101	1.06
2N2218A	26	2N3393	22	2N4249	22	2N5134	20	2N5418	30	2N6101	1.06
2N219	26	2N3414	22	2N4249	22	2N5134	20	2N5418	30	2N6101	1.06
2N2219A	26	2N3414	22	2N4249	22	2N5134	20	2N5418	30	2N6101	1.06
2N2221A	25	2N3440	100	2N4249	22	2N5134	20	2N5418	30	2N6101	1.06
2N2222	22	2N3442	100	2N4249	22	2N5134	20	2N5418	30	2N6101	1.06
2N2224	24	2N3553	80	2N4249	22	2N5134	20	2N5418	30	2N6101	1.06
2N2368	30	2N3563	15	2N4249	22	2N5134	20	2N5418	30	2N6101	1.06
2N2369	30	2N3564	15	2N4249	22	2N5134	20	2N5418	30	2N6101	1.06
2N2369A	30	2N3565	15	2N4249	22	2N5134	20	2N5418	30	2N6101	1.06
2N2475	50	2N3567	19	2N4249	22	2N5134	20	2N5418	30	2N6101	1.06
2N2484	30	2N3568	20	2N4249	22	2N5134	20	2N5418	30	2N6101	1.06
2N2605	50	2N3569	18	2N4249	22	2N5134	20	2N5418	30	2N6101	1.06
2N2610	2.00	2N3570	18	2N4249	22	2N5134	20	2N5418	30	2N6101	1.06
2N2646	70	2N3582A	22	2N4249	22	2N5134	20				



HYBRID AUDIO POWER AMPLIFIERS

- Multi-purpose linear amplifiers for commercial and industrial applications.
- Less than 0.5% harmonic distortion at full power level.
- 1/2 dB response from 20 to 100,000 Hz.
- Single or split (dual) power supply.
- Rugged, compact and lightweight packages.
- Built-in current limiting for SI-1050G and efficient heat radiating construction.

TYPICAL CONNECTIONS
SI-1050G WITH SPLIT SUPPLY

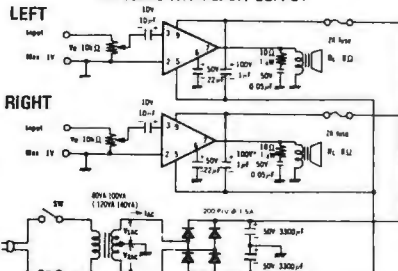

SANKEN Series SI-1000G amplifiers are self-contained power hybrid amplifiers designed for Hi-Fi, stereo, musical instruments, public address systems and other audio applications. The amplifiers have quasi-complementary class B output. The circuit employs flip-chip transistors with high reliability and passivated chip power transistors with excellent secondary breakdown strength. Built-in current limiting is provided for SI-1050G and all devices can be operated from a single or split power supply.

- SI-1010G (10W output) ... \$ 6.90
- SI-1020G (20W output) ... \$13.95
- SI-1050G (50W output) ... \$26.80

Data Sheet with Application Notes — \$0.50

7400N SERIES

7400N .16	7400N .42	7400N .55	7400N .70	7400N .85	7400N 1.10	7400N 1.30	7400N 1.50	7400N 1.70	7400N 1.90	7400N 2.10	7400N 2.30	7400N 2.50	7400N 2.70	7400N 2.90	7400N 3.10	7400N 3.30	7400N 3.50	7400N 3.70	7400N 3.90	7400N 4.10	7400N 4.30	7400N 4.50	7400N 4.70	7400N 4.90	7400N 5.10	7400N 5.30	7400N 5.50	7400N 5.70	7400N 5.90	7400N 6.10	7400N 6.30	7400N 6.50	7400N 6.70	7400N 6.90	7400N 7.10	7400N 7.30	7400N 7.50	7400N 7.70	7400N 7.90	7400N 8.10	7400N 8.30	7400N 8.50	7400N 8.70	7400N 8.90	7400N 9.10	7400N 9.30	7400N 9.50	7400N 9.70	7400N 9.90	7400N 10.10	7400N 10.30	7400N 10.50	7400N 10.70	7400N 10.90	7400N 11.10	7400N 11.30	7400N 11.50	7400N 11.70	7400N 11.90	7400N 12.10	7400N 12.30	7400N 12.50	7400N 12.70	7400N 12.90	7400N 13.10	7400N 13.30	7400N 13.50	7400N 13.70	7400N 13.90	7400N 14.10	7400N 14.30	7400N 14.50	7400N 14.70	7400N 14.90	7400N 15.10	7400N 15.30	7400N 15.50	7400N 15.70	7400N 15.90	7400N 16.10	7400N 16.30	7400N 16.50	7400N 16.70	7400N 16.90	7400N 17.10	7400N 17.30	7400N 17.50	7400N 17.70	7400N 17.90	7400N 18.10	7400N 18.30	7400N 18.50	7400N 18.70	7400N 18.90	7400N 19.10	7400N 19.30	7400N 19.50	7400N 19.70	7400N 19.90	7400N 20.10	7400N 20.30	7400N 20.50	7400N 20.70	7400N 20.90	7400N 21.10	7400N 21.30	7400N 21.50	7400N 21.70	7400N 21.90	7400N 22.10	7400N 22.30	7400N 22.50	7400N 22.70	7400N 22.90	7400N 23.10	7400N 23.30	7400N 23.50	7400N 23.70	7400N 23.90	7400N 24.10	7400N 24.30	7400N 24.50	7400N 24.70	7400N 24.90	7400N 25.10	7400N 25.30	7400N 25.50	7400N 25.70	7400N 25.90	7400N 26.10	7400N 26.30	7400N 26.50	7400N 26.70	7400N 26.90	7400N 27.10	7400N 27.30	7400N 27.50	7400N 27.70	7400N 27.90	7400N 28.10	7400N 28.30	7400N 28.50	7400N 28.70	7400N 28.90	7400N 29.10	7400N 29.30	7400N 29.50	7400N 29.70	7400N 29.90	7400N 30.10	7400N 30.30	7400N 30.50	7400N 30.70	7400N 30.90	7400N 31.10	7400N 31.30	7400N 31.50	7400N 31.70	7400N 31.90	7400N 32.10	7400N 32.30	7400N 32.50	7400N 32.70	7400N 32.90	7400N 33.10	7400N 33.30	7400N 33.50	7400N 33.70	7400N 33.90	7400N 34.10	7400N 34.30	7400N 34.50	7400N 34.70	7400N 34.90	7400N 35.10	7400N 35.30	7400N 35.50	7400N 35.70	7400N 35.90	7400N 36.10	7400N 36.30	7400N 36.50	7400N 36.70	7400N 36.90	7400N 37.10	7400N 37.30	7400N 37.50	7400N 37.70	7400N 37.90	7400N 38.10	7400N 38.30	7400N 38.50	7400N 38.70	7400N 38.90	7400N 39.10	7400N 39.30	7400N 39.50	7400N 39.70	7400N 39.90	7400N 40.10	7400N 40.30	7400N 40.50	7400N 40.70	7400N 40.90	7400N 41.10	7400N 41.30	7400N 41.50	7400N 41.70	7400N 41.90	7400N 42.10	7400N 42.30	7400N 42.50	7400N 42.70	7400N 42.90	7400N 43.10	7400N 43.30	7400N 43.50	7400N 43.70	7400N 43.90	7400N 44.10	7400N 44.30	7400N 44.50	7400N 44.70	7400N 44.90	7400N 45.10	7400N 45.30	7400N 45.50	7400N 45.70	7400N 45.90	7400N 46.10	7400N 46.30	7400N 46.50	7400N 46.70	7400N 46.90	7400N 47.10	7400N 47.30	7400N 47.50	7400N 47.70	7400N 47.90	7400N 48.10	7400N 48.30	7400N 48.50	7400N 48.70	7400N 48.90	7400N 49.10	7400N 49.30	7400N 49.50	7400N 49.70	7400N 49.90	7400N 50.10	7400N 50.30	7400N 50.50	7400N 50.70	7400N 50.90	7400N 51.10	7400N 51.30	7400N 51.50	7400N 51.70	7400N 51.90	7400N 52.10	7400N 52.30	7400N 52.50	7400N 52.70	7400N 52.90	7400N 53.10	7400N 53.30	7400N 53.50	7400N 53.70	7400N 53.90	7400N 54.10	7400N 54.30	7400N 54.50	7400N 54.70	7400N 54.90	7400N 55.10	7400N 55.30	7400N 55.50	7400N 55.70	7400N 55.90	7400N 56.10	7400N 56.30	7400N 56.50	7400N 56.70	7400N 56.90	7400N 57.10	7400N 57.30	7400N 57.50	7400N 57.70	7400N 57.90	7400N 58.10	7400N 58.30	7400N 58.50	7400N 58.70	7400N 58.90	7400N 59.10	7400N 59.30	7400N 59.50	7400N 59.70	7400N 59.90	7400N 60.10	7400N 60.30	7400N 60.50	7400N 60.70	7400N 60.90	7400N 61.10	7400N 61.30	7400N 61.50	7400N 61.70	7400N 61.90	7400N 62.10	7400N 62.30	7400N 62.50	7400N 62.70	7400N 62.90	7400N 63.10	7400N 63.30	7400N 63.50	7400N 63.70	7400N 63.90	7400N 64.10	7400N 64.30	7400N 64.50	7400N 64.70	7400N 64.90	7400N 65.10	7400N 65.30	7400N 65.50	7400N 65.70	7400N 65.90	7400N 66.10	7400N 66.30	7400N 66.50	7400N 66.70	7400N 66.90	7400N 67.10	7400N 67.30	7400N 67.50	7400N 67.70	7400N 67.90	7400N 68.10	7400N 68.30	7400N 68.50	7400N 68.70	7400N 68.90	7400N 69.10	7400N 69.30	7400N 69.50	7400N 69.70	7400N 69.90	7400N 70.10	7400N 70.30	7400N 70.50	7400N 70.70	7400N 70.90	7400N 71.10	7400N 71.30	7400N 71.50	7400N 71.70	7400N 71.90	7400N 72.10	7400N 72.30	7400N 72.50	7400N 72.70	7400N 72.90	7400N 73.10	7400N 73.30	7400N 73.50	7400N 73.70	7400N 73.90	7400N 74.10	7400N 74.30	7400N 74.50	7400N 74.70	7400N 74.90	7400N 75.10	7400N 75.30	7400N 75.50	7400N 75.70	7400N 75.90	7400N 76.10	7400N 76.30	7400N 76.50	7400N 76.70	7400N 76.90	7400N 77.10	7400N 77.30	7400N 77.50	7400N 77.70	7400N 77.90	7400N 78.10	7400N 78.30	7400N 78.50	7400N 78.70	7400N 78.90	7400N 79.10	7400N 79.30	7400N 79.50	7400N 79.70	7400N 79.90	7400N 80.10	7400N 80.30	7400N 80.50	7400N 80.70	7400N 80.90	7400N 81.10	7400N 81.30	7400N 81.50	7400N 81.70	7400N 81.90	7400N 82.10	7400N 82.30	7400N 82.50	7400N 82.70	7400N 82.90	7400N 83.10	7400N 83.30	7400N 83.50	7400N 83.70	7400N 83.90	7400N 84.10	7400N 84.30	7400N 84.50	7400N 84.70	7400N 84.90	7400N 85.10	7400N 85.30	7400N 85.50	7400N 85.70	7400N 85.90	7400N 86.10	7400N 86.30	7400N 86.50	7400N 86.70	7400N 86.90	7400N 87.10	7400N 87.30	7400N 87.50	7400N 87.70	7400N 87.90	7400N 88.10	7400N 88.30	7400N 88.50	7400N 88.70	7400N 88.90	7400N 89.10	7400N 89.30	7400N 89.50	7400N 89.70	7400N 89.90	7400N 90.10	7400N 90.30	7400N 90.50	7400N 90.70	7400N 90.90	7400N 91.10	7400N 91.30	7400N 91.50	7400N 91.70	7400N 91.90	7400N 92.10	7400N 92.30	7400N 92.50	7400N 92.70	7400N 92.90	7400N 93.10	7400N 93.30	7400N 93.50	7400N 93.70	7400N 93.90	7400N 94.10	7400N 94.30	7400N 94.50	7400N 94.70	7400N 94.90	7400N 95.10	7400N 95.30	7400N 95.50	7400N 95.70	7400N 95.90	7400N 96.10	7400N 96.30	7400N 96.50	7400N 96.70	7400N 96.90	7400N 97.10	7400N 97.30	7400N 97.50	7400N 97.70	7400N 97.90	7400N 98.10	7400N 98.30	7400N 98.50	7400N 98.70	7400N 98.90	7400N 99.10	7400N 99.30	7400N 99.50	7400N 99.70	7400N 99.90	7400N 100.10	7400N 100.30	7400N 100.50	7400N 100.70	7400N 100.90	7400N 101.10	7400N 101.30	7400N 101.50	7400N 101.70	7400N 101.90	7400N 102.10	7400N 102.30	7400N 102.50	7400N 102.70	7400N 102.90	7400N 103.10	7400N 103.30	7400N 103.50	7400N 103.70	7400N 103.90	7400N 104.10	7400N 104.30	7400N 104.50	7400N 104.70	7400N 104.90	7400N 105.10	7400N 105.30	7400N 105.50	7400N 105.70	7400N 105.90	7400N 106.10	7400N 106.30	7400N 106.50	7400N 106.70	7400N 106.90	7400N 107.10	7400N 107.30	7400N 107.50	7400N 107.70	7400N 107.90	7400N 108.10	7400N 108.30	7400N 108.50	7400N 108.70	7400N 108.90	7400N 109.10	7400N 109.30	7400N 109.50	7400N 109.70	7400N 109.90	7400N 110.10	7400N 110.30	7400N 110.50	7400N 110.70	7400N 110.90	7400N 111.10	7400N 111.30	7400N 111.50	7400N 111.70	7400N 111.90	7400N 112.10	7400N 112.30	7400N 112.50	7400N 112.70	7400N 112.90	7400N 113.10	7400N 113.30	7400N 113.50	7400N 113.70	7400N 113.90	7400N 114.10	7400N 114.30	7400N 114.50	7400N 114.70	7400N 114.90	7400N 115.10	7400N 115.30	7400N 115.50	7400N 115.70	7400N 115.90	7400N 116.10	7400N 116.30	7400N 116.50	7400N 116.70	7400N 116.90	7400N 117.10	7400N 117.30	7400N 117.50	7400N 117.70	7400N 117.90	7400N 118.10	7400N 118.30	7400N 118.50	7400N 118.70	7400N 118.90	7400N 119.10	7400N 119.30	7400N 119.50	7400N 119.70	7400N 119.90	7400N 120.10	7400N 120.30	7400N 120.50	7400N 120.70	7400N 120.90	7400N 121.10	7400N 121.30	7400N 121.50	7400N 121.70	7400N 121.90	7400N 122.10	7400N 122.30	7400N 122.50	7400N 122.70	7400N 122.90	7400N 123.10	7400N 123.30	7400N 123.50	7400N 123.70	7400N 123.90	7400N 124.10	7400N 124.30	7400N 124.50	7400N 124.70	7400N 124.90	7400N 125.10	7400N 125.30	7400N 125.50	7400N 125.70	7400N 125.90	7400N 126.10	7400N 126.30	7400N 126.50	7400N 126.70	7400N 126.90	7400N 127.10	7400N 127.30	7400N 127.50	7400N 127.70	7400N 127.90	7400N 128.10	7400N 128.30	7400N 128.50	7400N 128.70	7400N 128.90	7400N 129.10	7400N 129.30	7400N 129.50	7400N 129.70	7400N 129.90	7400N 130.10	7400N 130.30	7400N 130.50	7400N 130.70	7400N 130.90	7400N 131.10	7400N 131.30	7400N 131.50	7400N 131.70	7400N 131.90	7400N 132.10	7400N 132.30	7400N 132.50	7400N 132.70	7400N 132.90	7400N 133.10	7400N 133.30	7400N 133.50	7400N 133.70	7400N 133.90	7400N 134.10	7400N 134.30	7400N 134.50	7400N 134.70	7400N 134.90	7400N 135.10	7400N 135.30	7400N 135.50	7400N 135.70	7400N 135.90	7400N 136.10	7400N 136.30	7400N 136.50	7400N 136.70	7400N 136.90	7400N 137.10	7400N 137.30	7400N 137.50	7400N 137.70	7400N 137.90	7400N 138.10	7400N 138.30	7400N 138.50	7400N 138.70	7400N 138.90	7400N 139.10	7400N 139.30	7400N 139.50	7400N 139.70	7400N 139.90	7400N 140.10	7400N 140.30	7400N 140.50	7400N 140.70	7400N 140.90	7400N 141.10	7400N 141.30	7400N 141.50	7400N 141.70	7400N 141.90	7400N 142.10	7400N 142.30	7400N 142.50	7400N 142.70	7400N 142.90	7400N 143.10	7400N 143.30	7400N 143.50	7400N 1
-----------	-----------	-----------	-----------	-----------	------------	------------	------------	------------	------------	------------	------------	------------	------------	------------	------------	------------	------------	------------	------------	------------	------------	------------	------------	------------	------------	------------	------------	------------	------------	------------	------------	------------	------------	------------	------------	------------	------------	------------	------------	------------	------------	------------	------------	------------	------------	------------	------------	------------	------------	-------------	-------------	-------------	-------------	-------------	-------------	-------------	-------------	-------------	-------------	-------------	-------------	-------------	-------------	-------------	-------------	-------------	-------------	-------------	-------------	-------------	-------------	-------------	-------------	-------------	-------------	-------------	-------------	-------------	-------------	-------------	-------------	-------------	-------------	-------------	-------------	-------------	-------------	-------------	-------------	-------------	-------------	-------------	-------------	-------------	-------------	-------------	-------------	-------------	-------------	-------------	-------------	-------------	-------------	-------------	-------------	-------------	-------------	-------------	-------------	-------------	-------------	-------------	-------------	-------------	-------------	-------------	-------------	-------------	-------------	-------------	-------------	-------------	-------------	-------------	-------------	-------------	-------------	-------------	-------------	-------------	-------------	-------------	-------------	-------------	-------------	-------------	-------------	-------------	-------------	-------------	-------------	-------------	-------------	-------------	-------------	-------------	-------------	-------------	-------------	-------------	-------------	-------------	-------------	-------------	-------------	-------------	-------------	-------------	-------------	-------------	-------------	-------------	-------------	-------------	-------------	-------------	-------------	-------------	-------------	-------------	-------------	-------------	-------------	-------------	-------------	-------------	-------------	-------------	-------------	-------------	-------------	-------------	-------------	-------------	-------------	-------------	-------------	-------------	-------------	-------------	-------------	-------------	-------------	-------------	-------------	-------------	-------------	-------------	-------------	-------------	-------------	-------------	-------------	-------------	-------------	-------------	-------------	-------------	-------------	-------------	-------------	-------------	-------------	-------------	-------------	-------------	-------------	-------------	-------------	-------------	-------------	-------------	-------------	-------------	-------------	-------------	-------------	-------------	-------------	-------------	-------------	-------------	-------------	-------------	-------------	-------------	-------------	-------------	-------------	-------------	-------------	-------------	-------------	-------------	-------------	-------------	-------------	-------------	-------------	-------------	-------------	-------------	-------------	-------------	-------------	-------------	-------------	-------------	-------------	-------------	-------------	-------------	-------------	-------------	-------------	-------------	-------------	-------------	-------------	-------------	-------------	-------------	-------------	-------------	-------------	-------------	-------------	-------------	-------------	-------------	-------------	-------------	-------------	-------------	-------------	-------------	-------------	-------------	-------------	-------------	-------------	-------------	-------------	-------------	-------------	-------------	-------------	-------------	-------------	-------------	-------------	-------------	-------------	-------------	-------------	-------------	-------------	-------------	-------------	-------------	-------------	-------------	-------------	-------------	-------------	-------------	-------------	-------------	-------------	-------------	-------------	-------------	-------------	-------------	-------------	-------------	-------------	-------------	-------------	-------------	-------------	-------------	-------------	-------------	-------------	-------------	-------------	-------------	-------------	-------------	-------------	-------------	-------------	-------------	-------------	-------------	-------------	-------------	-------------	-------------	-------------	-------------	-------------	-------------	-------------	-------------	-------------	-------------	-------------	-------------	-------------	-------------	-------------	-------------	-------------	-------------	-------------	-------------	-------------	-------------	-------------	-------------	-------------	-------------	-------------	-------------	-------------	-------------	-------------	-------------	-------------	-------------	-------------	-------------	-------------	-------------	-------------	-------------	-------------	-------------	-------------	-------------	-------------	-------------	-------------	-------------	-------------	-------------	-------------	-------------	-------------	-------------	-------------	-------------	-------------	-------------	-------------	-------------	-------------	-------------	-------------	-------------	-------------	-------------	-------------	-------------	-------------	-------------	-------------	-------------	-------------	-------------	-------------	-------------	-------------	-------------	-------------	-------------	-------------	-------------	-------------	-------------	-------------	-------------	-------------	-------------	-------------	-------------	-------------	-------------	-------------	-------------	-------------	-------------	-------------	-------------	-------------	-------------	-------------	-------------	-------------	-------------	-------------	-------------	-------------	-------------	-------------	-------------	-------------	-------------	-------------	-------------	-------------	-------------	-------------	-------------	-------------	-------------	-------------	-------------	-------------	-------------	-------------	-------------	-------------	-------------	-------------	-------------	-------------	-------------	-------------	-------------	-------------	-------------	-------------	-------------	-------------	-------------	-------------	-------------	-------------	-------------	-------------	-------------	-------------	-------------	-------------	-------------	-------------	--------------	--------------	--------------	--------------	--------------	--------------	--------------	--------------	--------------	--------------	--------------	--------------	--------------	--------------	--------------	--------------	--------------	--------------	--------------	--------------	--------------	--------------	--------------	--------------	--------------	--------------	--------------	--------------	--------------	--------------	--------------	--------------	--------------	--------------	--------------	--------------	--------------	--------------	--------------	--------------	--------------	--------------	--------------	--------------	--------------	--------------	--------------	--------------	--------------	--------------	--------------	--------------	--------------	--------------	--------------	--------------	--------------	--------------	--------------	--------------	--------------	--------------	--------------	--------------	--------------	--------------	--------------	--------------	--------------	--------------	--------------	--------------	--------------	--------------	--------------	--------------	--------------	--------------	--------------	--------------	--------------	--------------	--------------	--------------	--------------	--------------	--------------	--------------	--------------	--------------	--------------	--------------	--------------	--------------	--------------	--------------	--------------	--------------	--------------	--------------	--------------	--------------	--------------	--------------	--------------	--------------	--------------	--------------	--------------	--------------	--------------	--------------	--------------	--------------	--------------	--------------	--------------	--------------	--------------	--------------	--------------	--------------	--------------	--------------	--------------	--------------	--------------	--------------	--------------	--------------	--------------	--------------	--------------	--------------	--------------	--------------	--------------	--------------	--------------	--------------	--------------	--------------	--------------	--------------	--------------	--------------	--------------	--------------	--------------	--------------	--------------	--------------	--------------	--------------	--------------	--------------	--------------	--------------	--------------	--------------	--------------	--------------	--------------	--------------	--------------	--------------	--------------	--------------	--------------	--------------	--------------	--------------	--------------	--------------	--------------	--------------	--------------	--------------	--------------	--------------	--------------	--------------	--------------	--------------	--------------	--------------	--------------	--------------	--------------	--------------	--------------	--------------	--------------	--------------	--------------	--------------	--------------	--------------	--------------	--------------	--------------	--------------	--------------	--------------	--------------	--------------	--------------	--------------	--------------	--------------	--------------	--------------	--------------	--------------	--------------	--------------	--------------	--------------	---------

ACUSTIC COUPLER

\$47.50

This coupler was manufactured by Novation, Inc., Tarzana, Ca. for use in Texas Instruments model 725 Electronic Terminal. It is compatible with Bell 103 and 113 data sets or the equivalent. The coupler operates asynchronously to a maximum speed of 300 baud in the full or half duplex mode. All signal outputs are compatible with TTL. Transmitt freq. is 12.25khz, for mark and 10.75khz. for space. Receive freq. is 22.25khz. for mark and 20.25khz. for space. Unit requires 12v dc and 5 vdc for operation. Complete with schematic and all pertinent information fully reconditioned, calibrated and guaranteed.

RS232 to TTL to RS232 converter kit.....\$4.50 (includes P.C. board and schematic)

PITTMAN 12 VDC MOTOR \$1.95 each
The Pittman runs on as low as 2 volts, rated 12 volts 250 ma., 2.8 inch oz. torque at 5000RPM. 1 1/8"DIA X 2" long with 0.118" shaft. New, Guaranteed.

DO-IT-YOURSELF AND SAVE! NEW!

ETCH MATERIAL

ACE Makes It Easy With Etch Powder. Etch 'em To Your Own Specifications.

EP-1.....makes.....1qt.....\$1.50
EP-2.....makes.....1gal.....\$3.50 (with instructions)

PRINTED CIRCUIT BOARDS

G-10 1/16" Unetched Copper Clad
1oz. 2-sided or 2 oz. 1-sided

SIZE	1	10	100
3"x8"	.50	2.50	19.95
5"x7"	.75	4.00	29.95
6"x6"	.75	4.00	29.95
4"x12"	1.00	5.00	39.95

contact ACE for quotes on custom sizes

KYNAR WIRE WRAP WIRE

Solid Silver Plated 30 AWG Blue, Red, Yellow, Black, Green, or White.

100' Spool.....	\$2.50
500' Spool.....	\$9.95
1000' Spool.....	\$19.95

26 AWG Red or Black
500' Spool.....\$7.95
1000' Spool.....\$12.50

PLEASE SPECIFY COLOR

10V 200ma P.C. mount 1 1/4"x 1 3/8" w x 1 1/8" thick. PRI: 117V
10/\$14.95
100/\$99.50

HEAT SINK Thermalloy p/n 6030B. Ideal for flat power devices. 1" w x 1 1/8" high
\$2.25 ea. 10/\$1.98

PoB 24V RELAY KHS17D11 4PDT 3 amp. herm. sealed. Pulled from new equipment. \$38/ea.

EAGLE-PICHER

CFV5 6volt SA.H. spill-proof, rechargeable battery. \$12.50/ea. 10/\$99.95. NEW - 1 YEAR WARRANTY

TRIAC

G.E. SC51B 15A 200V in pre-set case. Ideal for color organs. 10 for \$7.50 \$1.00 ea.

COMPUTER GRADE CAPS

32D POLYLYTIC 5900FD-60VDC 10/812.50
36D POLYLYTIC 5000FD-60VDC 10/819.00

MODEL 6310
1392 turns 50mh 65ma
10 for \$2.95

MINI KIT
60HZ. CRYSTAL TIME BASE SPECIAL OFFER ON MINI KIT INCLUDES MM5369 and 3879.545KHZ. CRYSTAL with SCHEMATIC. \$3.95

SPECIAL OFFER ON 1N914B 100 for \$4.95 1000 for \$39.95

STANDARDS KIT

An assortment of precision components for calibration of test equipment. Kit includes (10) assorted 1% capacitors, (10) assorted 0.01% resistors, and (1) temperature compensated zener reference diode. ONLY \$6.95

DYNAMIC RAM TMS4030JL

4096-BIT low power 400MHz. removed from sockets tested and guaranteed. \$9.95/ea. with 22 pin socket and data. 8 For \$64.95

HIGH POWER RECTIFIER

Varo 11407 6000V 750ma \$2.50/ea.

ROTARY SWITCHES

Rated 250 ma @ 28 VDC. Single pole, 10 position, non-shorting. Model 87 by Spectrol. (P.C. mount) \$7.12 Screwdriver Adjust \$7.5 Knob Adjust \$7.5 10 for \$5.95

STACKED-FOIL CAPS

Metalized polycarbon with stack foil construction. Holds volume to half that of equivalent metalized film types and offers extremely low self-induction. P.C. mt. 100 for \$1.60 1000 for \$12.50 10,000 for \$99.00

ZENER DIODE

1N752 5.6V 400mW 100 for \$5.95 1000 for \$49.95

HARDWARE

VALB. MIXED ELECTRONIC HARDWARE.....\$1.00

WRITE FOR FREE CATALOG

PERMA-FLEX TAPE

3" wide x 66' long. All weather, 8000V (.085 thick) Black. \$1.00 per roll, \$2.95 per 10 roll package. UL APPROVED

WIRE DISPENSER

With 50' roll of 30AWG Kynar. Cuts the wire to length. Strips 1" of insulation. Refillable spool. BLUE, YELLOW, WHITE, or RED

PHOTO-FLASH CAP

600mfd 360V (3/4"x 1" dia) \$1.98 ea. 10 for \$15.00

TEFLON TUBING CLEAR 1/8 GA.

Extremely high operating temperature range and chemical inertness. Will not crack or become brittle. Remains flexible throughout entire operating temp. range. 100' roll \$4.95 1000' roll \$24.95

LOTITE SUPERBONDER

Bonds Rubber, Plastic, Metal in Seconds. Compare at \$1.98 for 0.1oz. elsewhere. Comparable with Eastman 910. 1oz. Bottle \$4.95

THIS DEAL

STANDARD KIT \$6.95
DYNAMIC RAM \$9.95
HIGH POWER RECTIFIER \$2.50
ROTARY SWITCHES \$7.50

LITTLE VINYL FEET

self-sticking square or round feet. ACE SPECIAL SHEET OF 50 \$1.00

SLIDE SWITCH

SPST 4A@125VAC 1/8" mt. ctrs. 100 leads 100 for \$2.50

WELL MIXED ASSORTMENT

INCLUDES TTL, MEMORY, AND SPECIAL FUNCTION IC's. ALMOST ALL MARKED. OUR TEST SHOW VERY HIGH YIELD. 100 FOR \$1.98

CIRCLE NO. 2 ON FREE INFORMATION CARD

<h4>UNIVERSAL 4K x 8 MEMORY BOARD KIT \$74.50</h4> <p>32-2102-1 fully buffered, 16 address lines, on board decoding for any 4 of 64 pages, standard 44 pin buss.</p>	<h4>PRINTED CIRCUIT BOARD</h4> <p>4 1/2" x 6 1/2" SINGLE SIDED EPOXY BOARD 1/16" thick, unetched 5/22.60</p> <h4>7 WATT LD-65 LASER DIODE IR \$8.95</h4> <p>2N 3820 P FET \$.45 2N 5457 N FET \$.45 2N2646 \$.45 EP 900 TRIGGER DIODES 4/ \$1.00 2N6028 HIROG. UJT \$.65 MINIATURE MULTI TURN TRIM POTS 100, 500, 1K, 2K, 5K, 10K, 25K, 50K, 100K, 200K, 500K 1 Meg. \$7.5 ea. \$32.00 MULTI TURN TRIM POTS Similar to Bourns 3010 style 3 1/2" x 5 1/2" x 1 1/4" 50, 100, 1K, 10K 50K ohms \$1.50 ea. \$34.00</p> <h4>VERIPAX PC BOARD</h4> <p>This board is a 1/16" single sided paper epoxy board, 4" x 6" DRILLED and ETCHED which will hold up to 21 single 14 pin IC's or 8, 16, or LSI DIP IC's with buses for power supply connector. \$4.00</p> <p>MV 5691 YELLOW GREEN \$.90 BIPOlar LED \$.50 FP 100 PHOTO TRANS. \$ 5.50 RED, YELLOW, GREEN or AMBER LARGE LED'S \$ 6/\$1.00 1L-5 (MCT-2) \$.75 MOLEX PINS \$ 100/\$1.00 10 WATT ZENERS 3.9, 4.7, 5.6, 8.2, 12, 15, 18, 22, 100, 150 or 200V. ea. \$.60 1 WATT ZENERS 4.7, 5.6, 10, 12, 15, 18 or 22V \$ ea. \$.25 MC6860 MODEM CHIP \$.95</p>	<h4>TRANSISTOR SPECIALS</h4> <table border="1"> <tr><td>2N3585 NPN S1 TO 66</td><td>\$.95</td></tr> <tr><td>2N3772 NPN S1 TO 3</td><td>\$ 1.60</td></tr> <tr><td>2N1546 PNP GE TO-3</td><td>\$.75</td></tr> <tr><td>2N4908 PNP S1 TO 3</td><td>\$ 1.00</td></tr> <tr><td>2N6056 PNP S1 TO 3 Darlington</td><td>\$ 1.70</td></tr> <tr><td>2N5086 PNP S1 TO 92</td><td>4/5 1.00</td></tr> <tr><td>2N6983 PNP TO 66</td><td>\$.60</td></tr> <tr><td>2N404 PNP GE TO 5</td><td>\$ 5/5 .00</td></tr> <tr><td>2N3919 NPN S1 TO 3 RF</td><td>\$ 1.50</td></tr> <tr><td>MP54 13 NPN S1 TO 92</td><td>3/5 1.00</td></tr> <tr><td>2N3767 NPN S1 TO 66</td><td>\$.70</td></tr> <tr><td>2N2222 NPN S1 TO 18</td><td>5/5 1.00</td></tr> <tr><td>2N3004 NPN S1 TO 92</td><td>\$.70</td></tr> <tr><td>2N3906 PNP S1 TO 92</td><td>5/5 1.00</td></tr> <tr><td>2N5296 NPN S1 TO 220</td><td>\$.50</td></tr> <tr><td>2N6109 PNP S1 TO 220</td><td>\$.55</td></tr> <tr><td>2N3638 PNP S1 TO 5</td><td>5/5 1.00</td></tr> <tr><td>2N6517 NPN TO 92 S1</td><td>3/5 1.00</td></tr> </table>	2N3585 NPN S1 TO 66	\$.95	2N3772 NPN S1 TO 3	\$ 1.60	2N1546 PNP GE TO-3	\$.75	2N4908 PNP S1 TO 3	\$ 1.00	2N6056 PNP S1 TO 3 Darlington	\$ 1.70	2N5086 PNP S1 TO 92	4/5 1.00	2N6983 PNP TO 66	\$.60	2N404 PNP GE TO 5	\$ 5/5 .00	2N3919 NPN S1 TO 3 RF	\$ 1.50	MP54 13 NPN S1 TO 92	3/5 1.00	2N3767 NPN S1 TO 66	\$.70	2N2222 NPN S1 TO 18	5/5 1.00	2N3004 NPN S1 TO 92	\$.70	2N3906 PNP S1 TO 92	5/5 1.00	2N5296 NPN S1 TO 220	\$.50	2N6109 PNP S1 TO 220	\$.55	2N3638 PNP S1 TO 5	5/5 1.00	2N6517 NPN TO 92 S1	3/5 1.00	<h4>Full Wave Bridges</h4> <table border="1"> <tr><th>PRV</th><th>2A</th><th>6A</th><th>25A</th></tr> <tr><td>200</td><td>75</td><td>1.25</td><td>2.00</td></tr> <tr><td>400</td><td>95</td><td>1.50</td><td>3.00</td></tr> <tr><td>600</td><td>120</td><td>1.75</td><td>4.00</td></tr> </table> <h4>SANKEN AUDIO POWER AMPS</h4> <p>\$1.01@ 60 WATTS.....\$ 7.95 \$1.02@ 20 WATTS.....\$15.95 \$1.05@ 60 WATTS.....\$27.95</p> <h4>TANTALUM CAPACITORS</h4> <table border="1"> <tr><td>22UF 35V 5 S1 00</td><td>6.8UF 35V 3 S1 00</td></tr> <tr><td>47UF 35V 5 S1 00</td><td>22UF 35V 5 S1 00</td></tr> <tr><td>68UF 35V 5 S1 00</td><td>30UF 6V 5 S1 00</td></tr> <tr><td>1UF 35V 5 S1 00</td><td>33UF 35V 5 S1 00</td></tr> <tr><td>2.2UF 20V 5 S1 00</td><td>47UF 20V 35</td></tr> <tr><td>3.3UF 35V 4 S1 00</td><td>68UF 15V 5 S1 00</td></tr> <tr><td>4.7UF 15V 5 S1 00</td><td>10UF 25V 5 S1 00</td></tr> </table> <p>M/001 ALARM CLOCK CHIP \$5.75</p> <h4>74LS SERIES</h4> <table border="1"> <tr><td>74LS00</td><td>-23</td><td>74LS125</td><td>-65</td><td>LM 101</td><td>-1</td></tr> <tr><td>74LS02</td><td>-23</td><td>74LS126</td><td>-65</td><td>LM 101</td><td>74B 21</td></tr> <tr><td>74LS03</td><td>-23</td><td>74LS132</td><td>-80</td><td>LM 307</td><td>-30</td></tr> <tr><td>74LS04</td><td>-28</td><td>74LS138</td><td>-72</td><td>LM 308</td><td>-95</td></tr> <tr><td>74LS05</td><td>-28</td><td>74LS139</td><td>-72</td><td>LM 311</td><td>-95</td></tr> <tr><td>74LS06</td><td>-23</td><td>74LS145</td><td>-115</td><td>LM 318</td><td>-135</td></tr> <tr><td>74LS09</td><td>-33</td><td>74LS151</td><td>-98</td><td>LM 319</td><td>-105</td></tr> <tr><td>74LS10</td><td>-23</td><td>74LS153</td><td>-98</td><td>LM 324</td><td>-105</td></tr> <tr><td>74LS11</td><td>-23</td><td>74LS155</td><td>-140</td><td>LM 339</td><td>-110</td></tr> <tr><td>74LS13</td><td>-50</td><td>74LS156</td><td>-95</td><td>LM 377</td><td>-250</td></tr> <tr><td>74LS15</td><td>-23</td><td>74LS157</td><td>-98</td><td>LM 380</td><td>-95</td></tr> <tr><td>74LS20</td><td>-23</td><td>74LS160</td><td>-102</td><td>LM 381</td><td>-125</td></tr> <tr><td>74LS21</td><td>-23</td><td>74LS161</td><td>-102</td><td>LM 382</td><td>-125</td></tr> <tr><td>74LS22</td><td>-23</td><td>74LS162</td><td>-102</td><td>LM 537</td><td>-250</td></tr> <tr><td>74LS27</td><td>-27</td><td>74LS163</td><td>-102</td><td>LM 553</td><td>-250</td></tr> <tr><td>74LS30</td><td>-23</td><td>74LS168</td><td>-110</td><td>LM 585</td><td>-44</td></tr> <tr><td>74LS32</td><td>-33</td><td>74LS169</td><td>-110</td><td>LM 556</td><td>-85</td></tr> <tr><td>74LS37</td><td>-37</td><td>74LS173</td><td>-80</td><td></td><td></td></tr> <tr><td>74LS38</td><td>-37</td><td>74LS174</td><td>-105</td><td>560</td><td>-2.00</td></tr> <tr><td>74LS44</td><td>-27</td><td>74LS175</td><td>-122</td><td>565</td><td>-1.10</td></tr> <tr><td>74LS51</td><td>-23</td><td>74LS190</td><td>-150</td><td>566</td><td>-1.50</td></tr> <tr><td>74LS54</td><td>-23</td><td>74LS191</td><td>-150</td><td>567</td><td>-1.50</td></tr> <tr><td>74LS74</td><td>-49</td><td>74LS192</td><td>-175</td><td>703</td><td>-90</td></tr> <tr><td>74LS90</td><td>-95</td><td>74LS193</td><td>-175</td><td>709</td><td>-25</td></tr> <tr><td>74LS42</td><td>-88</td><td>74LS195</td><td>-125</td><td>710</td><td>-35</td></tr> <tr><td>74LS73</td><td>-40</td><td>74LS196</td><td>-99</td><td>711</td><td>-35</td></tr> <tr><td>74LS97</td><td>-40</td><td>74LS197</td><td>-99</td><td>741 Cor V</td><td>.31</td></tr> <tr><td>74LS76</td><td>-40</td><td>74LS257</td><td>-135</td><td>747</td><td>-65</td></tr> <tr><td>74LS90</td><td>-89</td><td>74LS258</td><td>-138</td><td>LM 1310</td><td>2.50</td></tr> <tr><td>74LS82</td><td>-85</td><td>74LS266</td><td>-88</td><td>1466</td><td>-95</td></tr> <tr><td>74LS93</td><td>-85</td><td>74LS365</td><td>-66</td><td>1458</td><td>-60</td></tr> <tr><td>74LS109</td><td>-50</td><td>74LS366</td><td>-66</td><td>CA 3046</td><td>-75</td></tr> <tr><td>74LS112</td><td>-43</td><td>74LS367</td><td>-66</td><td>CA 3047</td><td>-95</td></tr> <tr><td>74LS113</td><td>-43</td><td>74LS368</td><td>-66</td><td>3900</td><td>-49</td></tr> <tr><td>74LS114</td><td>-43</td><td>74LS390</td><td>-220</td><td>8038CC</td><td>-3.90</td></tr> </table>	PRV	2A	6A	25A	200	75	1.25	2.00	400	95	1.50	3.00	600	120	1.75	4.00	22UF 35V 5 S1 00	6.8UF 35V 3 S1 00	47UF 35V 5 S1 00	22UF 35V 5 S1 00	68UF 35V 5 S1 00	30UF 6V 5 S1 00	1UF 35V 5 S1 00	33UF 35V 5 S1 00	2.2UF 20V 5 S1 00	47UF 20V 35	3.3UF 35V 4 S1 00	68UF 15V 5 S1 00	4.7UF 15V 5 S1 00	10UF 25V 5 S1 00	74LS00	-23	74LS125	-65	LM 101	-1	74LS02	-23	74LS126	-65	LM 101	74B 21	74LS03	-23	74LS132	-80	LM 307	-30	74LS04	-28	74LS138	-72	LM 308	-95	74LS05	-28	74LS139	-72	LM 311	-95	74LS06	-23	74LS145	-115	LM 318	-135	74LS09	-33	74LS151	-98	LM 319	-105	74LS10	-23	74LS153	-98	LM 324	-105	74LS11	-23	74LS155	-140	LM 339	-110	74LS13	-50	74LS156	-95	LM 377	-250	74LS15	-23	74LS157	-98	LM 380	-95	74LS20	-23	74LS160	-102	LM 381	-125	74LS21	-23	74LS161	-102	LM 382	-125	74LS22	-23	74LS162	-102	LM 537	-250	74LS27	-27	74LS163	-102	LM 553	-250	74LS30	-23	74LS168	-110	LM 585	-44	74LS32	-33	74LS169	-110	LM 556	-85	74LS37	-37	74LS173	-80			74LS38	-37	74LS174	-105	560	-2.00	74LS44	-27	74LS175	-122	565	-1.10	74LS51	-23	74LS190	-150	566	-1.50	74LS54	-23	74LS191	-150	567	-1.50	74LS74	-49	74LS192	-175	703	-90	74LS90	-95	74LS193	-175	709	-25	74LS42	-88	74LS195	-125	710	-35	74LS73	-40	74LS196	-99	711	-35	74LS97	-40	74LS197	-99	741 Cor V	.31	74LS76	-40	74LS257	-135	747	-65	74LS90	-89	74LS258	-138	LM 1310	2.50	74LS82	-85	74LS266	-88	1466	-95	74LS93	-85	74LS365	-66	1458	-60	74LS109	-50	74LS366	-66	CA 3046	-75	74LS112	-43	74LS367	-66	CA 3047	-95	74LS113	-43	74LS368	-66	3900	-49	74LS114	-43	74LS390	-220	8038CC	-3.90
2N3585 NPN S1 TO 66	\$.95																																																																																																																																																																																																																																																																																						
2N3772 NPN S1 TO 3	\$ 1.60																																																																																																																																																																																																																																																																																						
2N1546 PNP GE TO-3	\$.75																																																																																																																																																																																																																																																																																						
2N4908 PNP S1 TO 3	\$ 1.00																																																																																																																																																																																																																																																																																						
2N6056 PNP S1 TO 3 Darlington	\$ 1.70																																																																																																																																																																																																																																																																																						
2N5086 PNP S1 TO 92	4/5 1.00																																																																																																																																																																																																																																																																																						
2N6983 PNP TO 66	\$.60																																																																																																																																																																																																																																																																																						
2N404 PNP GE TO 5	\$ 5/5 .00																																																																																																																																																																																																																																																																																						
2N3919 NPN S1 TO 3 RF	\$ 1.50																																																																																																																																																																																																																																																																																						
MP54 13 NPN S1 TO 92	3/5 1.00																																																																																																																																																																																																																																																																																						
2N3767 NPN S1 TO 66	\$.70																																																																																																																																																																																																																																																																																						
2N2222 NPN S1 TO 18	5/5 1.00																																																																																																																																																																																																																																																																																						
2N3004 NPN S1 TO 92	\$.70																																																																																																																																																																																																																																																																																						
2N3906 PNP S1 TO 92	5/5 1.00																																																																																																																																																																																																																																																																																						
2N5296 NPN S1 TO 220	\$.50																																																																																																																																																																																																																																																																																						
2N6109 PNP S1 TO 220	\$.55																																																																																																																																																																																																																																																																																						
2N3638 PNP S1 TO 5	5/5 1.00																																																																																																																																																																																																																																																																																						
2N6517 NPN TO 92 S1	3/5 1.00																																																																																																																																																																																																																																																																																						
PRV	2A	6A	25A																																																																																																																																																																																																																																																																																				
200	75	1.25	2.00																																																																																																																																																																																																																																																																																				
400	95	1.50	3.00																																																																																																																																																																																																																																																																																				
600	120	1.75	4.00																																																																																																																																																																																																																																																																																				
22UF 35V 5 S1 00	6.8UF 35V 3 S1 00																																																																																																																																																																																																																																																																																						
47UF 35V 5 S1 00	22UF 35V 5 S1 00																																																																																																																																																																																																																																																																																						
68UF 35V 5 S1 00	30UF 6V 5 S1 00																																																																																																																																																																																																																																																																																						
1UF 35V 5 S1 00	33UF 35V 5 S1 00																																																																																																																																																																																																																																																																																						
2.2UF 20V 5 S1 00	47UF 20V 35																																																																																																																																																																																																																																																																																						
3.3UF 35V 4 S1 00	68UF 15V 5 S1 00																																																																																																																																																																																																																																																																																						
4.7UF 15V 5 S1 00	10UF 25V 5 S1 00																																																																																																																																																																																																																																																																																						
74LS00	-23	74LS125	-65	LM 101	-1																																																																																																																																																																																																																																																																																		
74LS02	-23	74LS126	-65	LM 101	74B 21																																																																																																																																																																																																																																																																																		
74LS03	-23	74LS132	-80	LM 307	-30																																																																																																																																																																																																																																																																																		
74LS04	-28	74LS138	-72	LM 308	-95																																																																																																																																																																																																																																																																																		
74LS05	-28	74LS139	-72	LM 311	-95																																																																																																																																																																																																																																																																																		
74LS06	-23	74LS145	-115	LM 318	-135																																																																																																																																																																																																																																																																																		
74LS09	-33	74LS151	-98	LM 319	-105																																																																																																																																																																																																																																																																																		
74LS10	-23	74LS153	-98	LM 324	-105																																																																																																																																																																																																																																																																																		
74LS11	-23	74LS155	-140	LM 339	-110																																																																																																																																																																																																																																																																																		
74LS13	-50	74LS156	-95	LM 377	-250																																																																																																																																																																																																																																																																																		
74LS15	-23	74LS157	-98	LM 380	-95																																																																																																																																																																																																																																																																																		
74LS20	-23	74LS160	-102	LM 381	-125																																																																																																																																																																																																																																																																																		
74LS21	-23	74LS161	-102	LM 382	-125																																																																																																																																																																																																																																																																																		
74LS22	-23	74LS162	-102	LM 537	-250																																																																																																																																																																																																																																																																																		
74LS27	-27	74LS163	-102	LM 553	-250																																																																																																																																																																																																																																																																																		
74LS30	-23	74LS168	-110	LM 585	-44																																																																																																																																																																																																																																																																																		
74LS32	-33	74LS169	-110	LM 556	-85																																																																																																																																																																																																																																																																																		
74LS37	-37	74LS173	-80																																																																																																																																																																																																																																																																																				
74LS38	-37	74LS174	-105	560	-2.00																																																																																																																																																																																																																																																																																		
74LS44	-27	74LS175	-122	565	-1.10																																																																																																																																																																																																																																																																																		
74LS51	-23	74LS190	-150	566	-1.50																																																																																																																																																																																																																																																																																		
74LS54	-23	74LS191	-150	567	-1.50																																																																																																																																																																																																																																																																																		
74LS74	-49	74LS192	-175	703	-90																																																																																																																																																																																																																																																																																		
74LS90	-95	74LS193	-175	709	-25																																																																																																																																																																																																																																																																																		
74LS42	-88	74LS195	-125	710	-35																																																																																																																																																																																																																																																																																		
74LS73	-40	74LS196	-99	711	-35																																																																																																																																																																																																																																																																																		
74LS97	-40	74LS197	-99	741 Cor V	.31																																																																																																																																																																																																																																																																																		
74LS76	-40	74LS257	-135	747	-65																																																																																																																																																																																																																																																																																		
74LS90	-89	74LS258	-138	LM 1310	2.50																																																																																																																																																																																																																																																																																		
74LS82	-85	74LS266	-88	1466	-95																																																																																																																																																																																																																																																																																		
74LS93	-85	74LS365	-66	1458	-60																																																																																																																																																																																																																																																																																		
74LS109	-50	74LS366	-66	CA 3046	-75																																																																																																																																																																																																																																																																																		
74LS112	-43	74LS367	-66	CA 3047	-95																																																																																																																																																																																																																																																																																		
74LS113	-43	74LS368	-66	3900	-49																																																																																																																																																																																																																																																																																		
74LS114	-43	74LS390	-220	8038CC	-3.90																																																																																																																																																																																																																																																																																		
<h4>DIP SOCKETS</h4> <table border="1"> <tr><td>8 PIN - 22 24 PIN - 40</td><td></td></tr> <tr><td>14 PIN - 25 28 PIN - 50</td><td></td></tr> <tr><td>16 PIN - 28 40 PIN - 60</td><td></td></tr> <tr><td>18 PIN - 30</td><td></td></tr> </table> <p>#24. EIGHT CONDUCTOR SPECTRA FLAT CABLE 10/\$1.50 100/\$13.50</p>	8 PIN - 22 24 PIN - 40		14 PIN - 25 28 PIN - 50		16 PIN - 28 40 PIN - 60		18 PIN - 30		<h4>SILICON POWER RECTIFIERS</h4> <table border="1"> <tr><td>PRV 1A 3A 12A 50A 125A</td><td></td></tr> <tr><td>100 06 14 30 75 85 3 7/8</td><td></td></tr> <tr><td>300 07 20 35 1.15 4.25</td><td></td></tr> <tr><td>400 09 25 50 1.40 6.50</td><td></td></tr> <tr><td>600 11 30 70 1.80 8.50</td><td></td></tr> <tr><td>800 15 35 90 2.30 10.50</td><td></td></tr> <tr><td>1000 20 45 110 2.75 12.50</td><td></td></tr> </table>	PRV 1A 3A 12A 50A 125A		100 06 14 30 75 85 3 7/8		300 07 20 35 1.15 4.25		400 09 25 50 1.40 6.50		600 11 30 70 1.80 8.50		800 15 35 90 2.30 10.50		1000 20 45 110 2.75 12.50		<h4>TTL IC SERIES</h4> <table border="1"> <tr><td>7400-.14</td><td>7445-.15</td><td>74150-.90</td></tr> <tr><td>7401-.14</td><td>7446-.65</td><td>74151-.60</td></tr> <tr><td>7402-.14</td><td>7447-.65</td><td>74153-.60</td></tr> <tr><td>7403-.14</td><td>7448-.65</td><td>74154-.95</td></tr> <tr><td>7404-.18</td><td>7450-.15</td><td>74155-.70</td></tr> <tr><td>7405-.25</td><td>7472-.29</td><td>74157-.58</td></tr> <tr><td>7407-.25</td><td>7473-.28</td><td>74161-.85</td></tr> <tr><td>7408-.18</td><td>7474-.29</td><td>74163-.80</td></tr> <tr><td>7408-.18</td><td>7475-.45</td><td>74164-.95</td></tr> <tr><td>7409-.17</td><td>7476-.30</td><td>74165-.95</td></tr> <tr><td>7410-.14</td><td>7480-.35</td><td>74173-1.20</td></tr> <tr><td>7411-.20</td><td>7483-.62</td><td>74174-.85</td></tr> <tr><td>7412-.20</td><td>7485-.87</td><td>74175-.92</td></tr> <tr><td>7413-.39</td><td>7486-.30</td><td>74176-.75</td></tr> <tr><td>7414-.63</td><td>7489-.185</td><td>74177-.75</td></tr> <tr><td>7416-.25</td><td>7490-.42</td><td>74180-.65</td></tr> <tr><td>7417-.25</td><td>7491-.58</td><td>74181-1.90</td></tr> <tr><td>7420-.14</td><td>7492-.43</td><td>74190-1.00</td></tr> <tr><td>7425-.25</td><td>7493-.45</td><td>74191-1.00</td></tr> <tr><td>7426-.22</td><td>7494-.70</td><td>74192-.83</td></tr> <tr><td>7427-.25</td><td>7495-.65</td><td>74193-.83</td></tr> <tr><td>7430-.14</td><td>7496-.65</td><td>74194-.85</td></tr> <tr><td>7432-.25</td><td>74107-.28</td><td>74195-.52</td></tr> <tr><td>7437-.21</td><td>7492-.43</td><td>74257 1.25</td></tr> <tr><td>7438-.21</td><td>74123-.65</td><td>74279 1.87</td></tr> <tr><td>7440-.14</td><td>74125-.40</td><td>75324 1.75</td></tr> <tr><td>7441-.70</td><td>74126-.40</td><td>75491 65</td></tr> <tr><td>7442-.40</td><td></td><td>75492 65</td></tr> </table>	7400-.14	7445-.15	74150-.90	7401-.14	7446-.65	74151-.60	7402-.14	7447-.65	74153-.60	7403-.14	7448-.65	74154-.95	7404-.18	7450-.15	74155-.70	7405-.25	7472-.29	74157-.58	7407-.25	7473-.28	74161-.85	7408-.18	7474-.29	74163-.80	7408-.18	7475-.45	74164-.95	7409-.17	7476-.30	74165-.95	7410-.14	7480-.35	74173-1.20	7411-.20	7483-.62	74174-.85	7412-.20	7485-.87	74175-.92	7413-.39	7486-.30	74176-.75	7414-.63	7489-.185	74177-.75	7416-.25	7490-.42	74180-.65	7417-.25	7491-.58	74181-1.90	7420-.14	7492-.43	74190-1.00	7425-.25	7493-.45	74191-1.00	7426-.22	7494-.70	74192-.83	7427-.25	7495-.65	74193-.83	7430-.14	7496-.65	74194-.85	7432-.25	74107-.28	74195-.52	7437-.21	7492-.43	74257 1.25	7438-.21	74123-.65	74279 1.87	7440-.14	74125-.40	75324 1.75	7441-.70	74126-.40	75491 65	7442-.40		75492 65																																																																																																																																																																											
8 PIN - 22 24 PIN - 40																																																																																																																																																																																																																																																																																							
14 PIN - 25 28 PIN - 50																																																																																																																																																																																																																																																																																							
16 PIN - 28 40 PIN - 60																																																																																																																																																																																																																																																																																							
18 PIN - 30																																																																																																																																																																																																																																																																																							
PRV 1A 3A 12A 50A 125A																																																																																																																																																																																																																																																																																							
100 06 14 30 75 85 3 7/8																																																																																																																																																																																																																																																																																							
300 07 20 35 1.15 4.25																																																																																																																																																																																																																																																																																							
400 09 25 50 1.40 6.50																																																																																																																																																																																																																																																																																							
600 11 30 70 1.80 8.50																																																																																																																																																																																																																																																																																							
800 15 35 90 2.30 10.50																																																																																																																																																																																																																																																																																							
1000 20 45 110 2.75 12.50																																																																																																																																																																																																																																																																																							
7400-.14	7445-.15	74150-.90																																																																																																																																																																																																																																																																																					
7401-.14	7446-.65	74151-.60																																																																																																																																																																																																																																																																																					
7402-.14	7447-.65	74153-.60																																																																																																																																																																																																																																																																																					
7403-.14	7448-.65	74154-.95																																																																																																																																																																																																																																																																																					
7404-.18	7450-.15	74155-.70																																																																																																																																																																																																																																																																																					
7405-.25	7472-.29	74157-.58																																																																																																																																																																																																																																																																																					
7407-.25	7473-.28	74161-.85																																																																																																																																																																																																																																																																																					
7408-.18	7474-.29	74163-.80																																																																																																																																																																																																																																																																																					
7408-.18	7475-.45	74164-.95																																																																																																																																																																																																																																																																																					
7409-.17	7476-.30	74165-.95																																																																																																																																																																																																																																																																																					
7410-.14	7480-.35	74173-1.20																																																																																																																																																																																																																																																																																					
7411-.20	7483-.62	74174-.85																																																																																																																																																																																																																																																																																					
7412-.20	7485-.87	74175-.92																																																																																																																																																																																																																																																																																					
7413-.39	7486-.30	74176-.75																																																																																																																																																																																																																																																																																					
7414-.63	7489-.185	74177-.75																																																																																																																																																																																																																																																																																					
7416-.25	7490-.42	74180-.65																																																																																																																																																																																																																																																																																					
7417-.25	7491-.58	74181-1.90																																																																																																																																																																																																																																																																																					
7420-.14	7492-.43	74190-1.00																																																																																																																																																																																																																																																																																					
7425-.25	7493-.45	74191-1.00																																																																																																																																																																																																																																																																																					
7426-.22	7494-.70	74192-.83																																																																																																																																																																																																																																																																																					
7427-.25	7495-.65	74193-.83																																																																																																																																																																																																																																																																																					
7430-.14	7496-.65	74194-.85																																																																																																																																																																																																																																																																																					
7432-.25	74107-.28	74195-.52																																																																																																																																																																																																																																																																																					
7437-.21	7492-.43	74257 1.25																																																																																																																																																																																																																																																																																					
7438-.21	74123-.65	74279 1.87																																																																																																																																																																																																																																																																																					
7440-.14	74125-.40	75324 1.75																																																																																																																																																																																																																																																																																					
7441-.70	74126-.40	75491 65																																																																																																																																																																																																																																																																																					
7442-.40		75492 65																																																																																																																																																																																																																																																																																					
<h4>SILICON SOLAR CELLS</h4> <p>2 1/4" diameter 4V at 500 ma. \$4.00 / .2V at 200 mils \$2.00</p> <h4>REGULATORS</h4> <table border="1"> <tr><td>309K \$.95</td><td>340K-5,12,15</td></tr> <tr><td>723 \$.50</td><td>or 24V \$.85</td></tr> <tr><td>LM 376 \$.60</td><td>340T-5, 6, 8, 9</td></tr> <tr><td>320K-5 or 15V \$1.40</td><td>15, 18, or 24V \$1.10</td></tr> <tr><td>320T-5, 12, 15, or 24V \$.85</td><td>78 MG \$.135</td></tr> <tr><td></td><td>79 MG \$.135</td></tr> </table>	309K \$.95	340K-5,12,15	723 \$.50	or 24V \$.85	LM 376 \$.60	340T-5, 6, 8, 9	320K-5 or 15V \$1.40	15, 18, or 24V \$1.10	320T-5, 12, 15, or 24V \$.85	78 MG \$.135		79 MG \$.135	<h4>TRIACS</h4> <table border="1"> <tr><td>PRV 1A 10A 25A 1.5A 5A 35A</td><td></td></tr> <tr><td>100 40 70 130 40 100 120</td><td></td></tr> <tr><td>200 70 110 175 60 70 120</td><td></td></tr> <tr><td>400 110 160 260 100 120 220</td><td></td></tr> <tr><td>800 170 230 360 160 160 320</td><td></td></tr> </table>	PRV 1A 10A 25A 1.5A 5A 35A		100 40 70 130 40 100 120		200 70 110 175 60 70 120		400 110 160 260 100 120 220		800 170 230 360 160 160 320		<h4>SCR'S</h4> <table border="1"> <tr><td>PRV 1A 10A 25A 1.5A 5A 35A</td><td></td></tr> <tr><td>100 40 70 130 40 100 120</td><td></td></tr> <tr><td>200 70 110 175 60 70 120</td><td></td></tr> <tr><td>400 110 160 260 100 120 220</td><td></td></tr> <tr><td>800 170 230 360 160 160 320</td><td></td></tr> </table>	PRV 1A 10A 25A 1.5A 5A 35A		100 40 70 130 40 100 120		200 70 110 175 60 70 120		400 110 160 260 100 120 220		800 170 230 360 160 160 320																																																																																																																																																																																																																																																						
309K \$.95	340K-5,12,15																																																																																																																																																																																																																																																																																						
723 \$.50	or 24V \$.85																																																																																																																																																																																																																																																																																						
LM 376 \$.60	340T-5, 6, 8, 9																																																																																																																																																																																																																																																																																						
320K-5 or 15V \$1.40	15, 18, or 24V \$1.10																																																																																																																																																																																																																																																																																						
320T-5, 12, 15, or 24V \$.85	78 MG \$.135																																																																																																																																																																																																																																																																																						
	79 MG \$.135																																																																																																																																																																																																																																																																																						
PRV 1A 10A 25A 1.5A 5A 35A																																																																																																																																																																																																																																																																																							
100 40 70 130 40 100 120																																																																																																																																																																																																																																																																																							
200 70 110 175 60 70 120																																																																																																																																																																																																																																																																																							
400 110 160 260 100 120 220																																																																																																																																																																																																																																																																																							
800 170 230 360 160 160 320																																																																																																																																																																																																																																																																																							
PRV 1A 10A 25A 1.5A 5A 35A																																																																																																																																																																																																																																																																																							
100 40 70 130 40 100 120																																																																																																																																																																																																																																																																																							
200 70 110 175 60 70 120																																																																																																																																																																																																																																																																																							
400 110 160 260 100 120 220																																																																																																																																																																																																																																																																																							
800 170 230 360 160 160 320																																																																																																																																																																																																																																																																																							
<h4>LED READOUTS</h4> <table border="1"> <tr><td>FND 359 C.C. 4" x 50 HP 7740, 3" C.C. \$1.25</td><td></td></tr> <tr><td>FND 700 C.C. 4" x 55 MAN-7, 3" C.A. \$.95</td><td></td></tr> <tr><td>FND 503 C.C. 5" x 85 NS 33-3 dig array \$.75</td><td></td></tr> <tr><td>FND 510 C.C. 5" x 85 DL 747 C.A. 6" \$1.95</td><td></td></tr> </table>	FND 359 C.C. 4" x 50 HP 7740, 3" C.C. \$1.25		FND 700 C.C. 4" x 55 MAN-7, 3" C.A. \$.95		FND 503 C.C. 5" x 85 NS 33-3 dig array \$.75		FND 510 C.C. 5" x 85 DL 747 C.A. 6" \$1.95		<h4>MINIATURE DIP SWITCHES</h4> <p>CTS-564 Four SPST switches in one multipid package \$1.75 CTS-206-8 Eight SPST switches in a 16 pin dip package \$1.95</p> <p>5 BV SPST miniature reed. relay normally open, 330 Ohm coil resistance \$ 75, 3 S2 00</p>	<h4>ALCO MINIATURE TOGGLE SWITCHES</h4> <table border="1"> <tr><td>MTA 106 SPDT \$1.20</td><td></td></tr> <tr><td>MTA 206 DPDT \$1.70</td><td></td></tr> </table>	MTA 106 SPDT \$1.20		MTA 206 DPDT \$1.70																																																																																																																																																																																																																																																																										
FND 359 C.C. 4" x 50 HP 7740, 3" C.C. \$1.25																																																																																																																																																																																																																																																																																							
FND 700 C.C. 4" x 55 MAN-7, 3" C.A. \$.95																																																																																																																																																																																																																																																																																							
FND 503 C.C. 5" x 85 NS 33-3 dig array \$.75																																																																																																																																																																																																																																																																																							
FND 510 C.C. 5" x 85 DL 747 C.A. 6" \$1.95																																																																																																																																																																																																																																																																																							
MTA 106 SPDT \$1.20																																																																																																																																																																																																																																																																																							
MTA 206 DPDT \$1.70																																																																																																																																																																																																																																																																																							

Terms: FOB Cambridge, Mass. Send Check or Money Order. Include Postage. Minimum Order \$5.00, COD's \$20.00

Send 25¢ for our catalog featuring Transistors and Rectifiers 145 Hampshire St., Cambridge, Mass.

140 SOLID STATE SALES P.O. BOX 74A SOMERVILLE, MASS. 02143 TEL. (617) 547-4005 WE SHIP OVER 95% OF OUR ORDERS THE DAY WE RECEIVE THEM POPULAR ELECTRONICS CIRCLE NO. 58 ON FREE INFORMATION CARD

ADVERTISERS INDEX

READER SERVICE NO.	ADVERTISER	PAGE NO.
1	A P Products Incorporated	26
2	Ace Electronic Parts	140
3	Active Electronic Sales Corp.	120
6	Advanced Microcomputer Products	122
7	Anrona Corp.	138, 139
	Audio Technica U.S., Inc.	104
8	Avanti Research & Development, Inc.	103
9	B & F Enterprises	128
68	B & K Precision, Product of Dynascan	111
	Burstein-Applebee	136
10	Byte Publications	105
	CREL, Capitol Radio Engineering Institute	38, 39, 40, 41
	Cleveland Institute of Electronics, Inc.	28, 29, 30, 31
12	Cobra, Product of Dynascan	SECOND COVER
11	Computer Depot	92
13	Contemporary Marketing, Inc.	95
14	Continental Specialties Corporation	43
15	Control & Information Systems, Inc.	93
16	Digi-Key Corporation	135
17	Digital Group, The	73
18	Drake Company, R.L.	113
19	E.D.I.	131
20	EICO	114, 115
21	Edmund Scientific Co.	142
22	Electra Company	2
23	Electronics Book Club	7
24	Eltron	128
25	Empire Scientific Corp.	56
26	Extron LIFESCREEN Projection System	113
	Fluke	45
	G.F.N. Industries	9
28	Godbout Elects., Bill.	130
29	Grantham College of Engineering	112
	Heath Company	106, 107, 108, 109
31	Hobby-tronix, Inc.	124
32	Illinois Audio	114
33	International Electronics Unlimited	134
	Intersil	12, 13
34	JMJ Technical Products, Inc.	136
36	JS & A	1
35	James Electronics	132, 133
36	Kedman Company	117
	Kenwood	21
37	Mclntosh Laboratory Inc.	105
38	MITS	27
	NRI Schools	16, 17, 18, 19
40	National Camera Supply	115
	National Technical Schools	88, 89, 90, 91
41	New-Tone Electronics	121
42	Nonatics Res. & Dev	116
43	OK Machine & Tool Corporation	101
44	Olson Electronics	130
45	Optoelectronics	137
46	PAIA Electronics, Inc.	116
47	Pathcom Inc.	FOURTH COVER
48	Pickering & Co.	THIRD COVER
49	Poly Paks	127
50	President Electronics, Inc.	33
51	Quest Electronics	141
52	Radio Hut	123
	Radio Shack	35
53	Ramsey Electronics	128
54	S.D. Sales Co.	129
55	Sansur Electronics Corp.	15
56	Schober Organ Corp., The	117
57	Scientific Audio Electronics, Inc.	6
64	Sencore	118
69	Shure Brothers Inc.	119
58	Solid State Sales	140
59	Southwest Technical Products Corporation	37
	Speakerlab	112
67	Stereo Corporation of America	118
	Superscope, Inc.	10, 11
60	Tn-Tek, Inc.	87
65	U.S. Pioneer	5
4	United Audio Products, Inc.	46
61	Vector Electronics Co.	87
62	Wersi Electronics Inc.	113
63	Yaesu Electronics Corp.	99

CLASSIFIED ADVERTISING 120, 122, 130, 131, 134, 136, 137, 141

MAGNETS

MAGNETS. All types. Specials-20 disc. or 10 bar, or 2 stick or 8 assorted magnets. \$1.00. Magnets, Box 192-H Randallstown, Maryland 21133.

DO-IT-YOURSELF

MODULAR TELEPHONES now available. Sets and components, compatible with Western Electric concept. Catalog 50 cents. Box 1147W, San Diego, California 92112.

TAPE-SLIDE SYNCHRONIZER, lap-dissolve, multiprojector audiovisual plans \$8.50. Free Catalog. Millers, 1896 Maywood, South Euclid, OH 44121.

BUILD Electronic devices in your home. Get started in your spare time. Big Profits — Experience not necessary. Write for free literature telling how. Electronic Develop Lab, Dept. D, Box 1535, Pinella Park, FL 33565.

MAKE PROFESSIONAL QUALITY PC boards with silk-screen techniques. Complete information, \$4.95 postpaid. TerraTronic Research, Box 5135P, Quincy, Ill. 62301.

Same day shipment. First line parts only. Factory tested. Guaranteed money back. Quality IC's and other components at factory prices.

INTEGRATED CIRCUITS

7400	17	74LS00	43	LM7417	4.50
7401	17	74LS01	38	LM7418	4.50
7402	17	74LS02	38	LM7419	4.50
7403	17	74LS03	38	LM7420	4.50
7404	17	74LS04	38	LM7421	4.50
7405	17	74LS05	38	LM7422	4.50
7406	17	74LS06	38	LM7423	4.50
7407	17	74LS07	38	LM7424	4.50
7408	17	74LS08	38	LM7425	4.50
7409	17	74LS09	38	LM7426	4.50
7410	17	74LS10	38	LM7427	4.50
7411	17	74LS11	38	LM7428	4.50
7412	17	74LS12	38	LM7429	4.50
7413	17	74LS13	38	LM7430	4.50
7414	17	74LS14	38	LM7431	4.50
7415	17	74LS15	38	LM7432	4.50
7416	17	74LS16	38	LM7433	4.50
7417	17	74LS17	38	LM7434	4.50
7418	17	74LS18	38	LM7435	4.50
7419	17	74LS19	38	LM7436	4.50
7420	17	74LS20	38	LM7437	4.50
7421	17	74LS21	38	LM7438	4.50
7422	17	74LS22	38	LM7439	4.50
7423	17	74LS23	38	LM7440	4.50
7424	17	74LS24	38	LM7441	4.50
7425	17	74LS25	38	LM7442	4.50
7426	17	74LS26	38	LM7443	4.50
7427	17	74LS27	38	LM7444	4.50
7428	17	74LS28	38	LM7445	4.50
7429	17	74LS29	38	LM7446	4.50
7430	17	74LS30	38	LM7447	4.50
7431	17	74LS31	38	LM7448	4.50
7432	17	74LS32	38	LM7449	4.50
7433	17	74LS33	38	LM7450	4.50
7434	17	74LS34	38	LM7451	4.50
7435	17	74LS35	38	LM7452	4.50
7436	17	74LS36	38	LM7453	4.50
7437	17	74LS37	38	LM7454	4.50
7438	17	74LS38	38	LM7455	4.50
7439	17	74LS39	38	LM7456	4.50
7440	17	74LS40	38	LM7457	4.50
7441	17	74LS41	38	LM7458	4.50
7442	17	74LS42	38	LM7459	4.50
7443	17	74LS43	38	LM7460	4.50
7444	17	74LS44	38	LM7461	4.50
7445	17	74LS45	38	LM7462	4.50
7446	17	74LS46	38	LM7463	4.50
7447	17	74LS47	38	LM7464	4.50
7448	17	74LS48	38	LM7465	4.50
7449	17	74LS49	38	LM7466	4.50
7450	17	74LS50	38	LM7467	4.50
7451	17	74LS51	38	LM7468	4.50
7452	17	74LS52	38	LM7469	4.50
7453	17	74LS53	38	LM7470	4.50
7454	17	74LS54	38	LM7471	4.50
7455	17	74LS55	38	LM7472	4.50
7456	17	74LS56	38	LM7473	4.50
7457	17	74LS57	38	LM7474	4.50
7458	17	74LS58	38	LM7475	4.50
7459	17	74LS59	38	LM7476	4.50
7460	17	74LS60	38	LM7477	4.50
7461	17	74LS61	38	LM7478	4.50
7462	17	74LS62	38	LM7479	4.50
7463	17	74LS63	38	LM7480	4.50
7464	17	74LS64	38	LM7481	4.50
7465	17	74LS65	38	LM7482	4.50
7466	17	74LS66	38	LM7483	4.50
7467	17	74LS67	38	LM7484	4.50
7468	17	74LS68	38	LM7485	4.50
7469	17	74LS69	38	LM7486	4.50
7470	17	74LS70	38	LM7487	4.50
7471	17	74LS71	38	LM7488	4.50
7472	17	74LS72	38	LM7489	4.50
7473	17	74LS73	38	LM7490	4.50
7474	17	74LS74	38	LM7491	4.50
7475	17	74LS75	38	LM7492	4.50
7476	17	74LS76	38	LM7493	4.50
7477	17	74LS77	38	LM7494	4.50
7478	17	74LS78	38	LM7495	4.50
7479	17	74LS79	38	LM7496	4.50
7480	17	74LS80	38	LM7497	4.50
7481	17	74LS81	38	LM7498	4.50
7482	17	74LS82	38	LM7499	4.50
7483	17	74LS83	38	LM7500	4.50
7484	17	74LS84	38	LM7501	4.50
7485	17	74LS85	38	LM7502	4.50
7486	17	74LS86	38	LM7503	4.50
7487	17	74LS87	38	LM7504	4.50
7488	17	74LS88	38	LM7505	4.50
7489	17	74LS89	38	LM7506	4.50
7490	17	74LS90	38	LM7507	4.50
7491	17	74LS91	38	LM7508	4.50
7492	17	74LS92	38	LM7509	4.50
7493	17	74LS93	38	LM7510	4.50
7494	17	74LS94	38	LM7511	4.50
7495	17	74LS95	38	LM7512	4.50
7496	17	74LS96	38	LM7513	4.50
7497	17	74LS97	38	LM7514	4.50
7498	17	74LS98	38	LM7515	4.50
7499	17	74LS99	38	LM7516	4.50
7500	17	74LS100	38	LM7517	4.50
7501	17	74LS101	38	LM7518	4.50
7502	17	74LS102	38	LM7519	4.50
7503	17	74LS103	38	LM7520	4.50
7504	17	74LS104	38	LM7521	4.50
7505	17	74LS105	38	LM7522	4.50
7506	17	74LS106	38	LM7523	4.50
7507	17	74LS107	38	LM7524	4.50
7508	17	74LS108	38	LM7525	4.50
7509	17	74LS109	38	LM7526	4.50
7510	17	74LS110	38	LM7527	4.50
7511	17	74LS111	38	LM7528	4.50
7512	17	74LS112	38	LM7529	4.50
7513	17	74LS113	38	LM7530	4.50
7514	17	74LS114	38	LM7531	4.50
7515	17	74LS115	38	LM7532	4.50
7516	17	74LS116	38	LM7533	4.50
7517	17	74LS117	38	LM7534	4.50
7518	17	74LS118	38	LM7535	4.50
7519	17	74LS119	38	LM7536	4.50
7520	17	74LS120	38	LM7537	4.50
7521	17	74LS121	38	LM7538	4.50
7522	17	74LS122	38	LM7539	4.50
7523	17	74LS123	38	LM7540	4.50
7524	17	74LS124	38	LM7541	4.50
7525	17	74LS125	38	LM7542	4.50
7526	17	74LS126	38	LM7543	4.50
7527	17	74LS127	38	LM7544	4.50
7528	17	74LS128	38	LM7545	4.50
7529	17	74LS129	38	LM7546	4.50
7530	17	74LS130	38	LM7547	4.50
7531	17	74LS131	38	LM7548	4.50
7532	17	74LS132	38	LM7549	4.50
7533	17	74LS133	38	LM7550	4.50
7534	17	74LS134	38	LM7551	4.50
7535	17	74LS135	38	LM7552	4.50
7536	17	74LS136	38	LM7553	4.50
7537	17	74LS137	38	LM7554	4.50
7538	17	74LS138	38	LM7555	4.50
7539	17	74LS139	38	LM7556	4.50
7540	17	74LS140	38	LM7557	4.50
7541	17	74LS141	38	LM7558	4.50
7542	17	74LS142	38	LM7559	4.50
7543	17	74LS143	38	LM7560	4.50
7544	17	74LS144	38	LM7561	4.50
7545	17	74LS145	38	LM7562	4.50
7546	17	74LS146	38	LM7563	4.50
7547	17	74LS147	38	LM7564	4.50
7548	17	74LS148	38	LM7565	4.50
7549	17	74LS149	38	LM7566	4.50
7550	17	74LS150	38	LM7567	4.50
7551	17	74LS151	38	LM7568	4.50
7552	17	74LS152	38	LM7569	4.50
7553	17	74LS153	38	LM7570	4.50
7554	17	74LS154	38	LM7571	4.50
7555	17	74LS155	38	LM7572	4.50
7556	17	74LS156	38	LM7573	4.50
7557	17	74LS157	38	LM7574	4.50
7558	17	74LS158	38	LM7575	4.50
7559	17	74LS159	38	LM7576	4.50
7560	17	74LS160	38	LM7577	4.50
7561	17	74LS161	38	LM7578	4.50
7562	17	74LS162	38	LM7579	4.50
7563	17	74LS163	38	LM7580	4.50
7564	17	74LS164	38	LM7581	4.50

EDMUND SCIENTIFIC

NEW WIDE FIELD TELESCOPE

Astroscan lets you enjoy clear, bright, wide-angle views of stars, moon, comets, etc. Completely portable, this unique $4\frac{1}{4}$ ", $f/4$ Newtonian reflector houses top quality optics. Designed for ease of handling and use, Astroscan weighs only 10 lbs. and stands 17" high. What an instrument!

No. 2001

Ppd.

\$149.95



PROFESSIONAL TIMING ACCURACY . . . Only \$49.95

Hand-held electronic digital stopwatch counts up, down, and sounds alarm. Full range (9 hr. 50 min. 59 sec.); bright LED display; matrix keyboard; start/stop reset buttons. Batteries. Size: $2\frac{3}{4}$ x $4\frac{1}{4}$ x $1\frac{1}{8}$ "

No. 1692

Ppd. **\$59.95**



Free Catalog

TUNE IN AM STATIONS UP TO 3000 MILES AWAY

Ultrasensitive super antenna pre-amplifies signal. Pick up ball games around the country, your home town, more. Directional indoor ant.; freq. and sensitivity controls; 110v AC; 60 cyc. Size: $3\frac{1}{2}$ x $9\frac{1}{16}$ x 11". Wt. 6 $\frac{1}{2}$ lb.

No. 72,263

Ppd. **\$177.50**

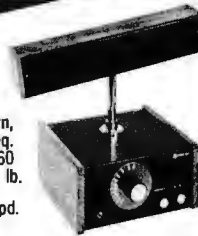

SAVE 50% — DELUXE AM/FM WALL RADIO
Great surplus buy saves you 50% on brand new AM/FM Deluxe Wall Radio w/ handsome silver/black control panel. Mount anywhere den, kitchen, bedroom, office, workshop. Self-cont. Philco-Ford radio chassis ($14\frac{1}{4}$ x $3\frac{3}{16}$ x $3\frac{1}{2}$ " w/11 transistors, vol. control, AM/FM hi-sensitivity tuner, AFC $2\frac{3}{4}$ " dia. speaker, $7\frac{1}{2}$ " 110V AC cord. Orig. cost \$30 ea. in 3000 quant. for nat'l. metal chain. Retail value over \$40! Buy several now.

No. 72,275 (READY TO PLAY!) . . .

\$22.50 Ppd.

SEE MUSIC IN PULSATING COLOR
3-Channel Color Organ lets you modulate 3 indep. strings of colored lamps w/ intensity of your music. "Audio light show" flashes, responds to rhythm, pitch!

No. 42,309 (ASSEMBLED) . . .

\$18.50

No. 42,336 (UN-ASSEMBLED) . . .

\$15.95 Ppd.



Free Catalog

KNOW YOUR ALPHA FROM THETA!
For greater relaxation & concentration, monitor your Alpha/Theta brainwaves with audio or visual signals on Biosone II. Features of \$200-up units. Incl. 3 feedback modes! 4-lb.

No. 1668 (9 $\frac{1}{2}$ x $5\frac{5}{8}$ x $4\frac{1}{4}$ "")

\$149.95

No. 71,809 (FOR BEGINNERS)

\$59.95



MEASURE WIND SPEED ANYWHERE

Hold handy (16 oz.!) low cost Anemometer into the wind, quickly read wind speed on its big dial—from 5 to 70 mph. Acc. to $\pm 3\%$ of full scale (2.1 mph); no batts., adjustments, recalibration req.!

No. 42,428 (7" HIGH) . . .

\$21.95 Ppd.



MYSTICAL MUSICAL MACHINE

Automatic 256-note pseudo-random tone pattern. Adj. beat, vol., pitch. Photocells vary tone of continuous "music." Output jack for patching, or tape hookup. 9V batt. incl.

No. 72,203

\$59.95 Ppd.



Free Catalog

Send for your FREE 164 page Edmund Scientific Catalog with over 4500 bargains



SENSITIVE TR METAL DETECTOR



Fully transistorized transmitter/receiver (TR) detector with sensitivity rivaling models twice the price. Built of rugged aluminum with a waterproof search coil. Detects a penny at 5". Wt. 2 lb. 6 oz.

No. 80,262

\$39.95 Ppd.

FREE CATALOG

EDMUND SCIENTIFIC CO.
Dept. AV18, Edscorp Bldg.
Barrington, New Jersey 08007

Send GIANT 164 Page Catalog packed with over 4,000 unusual bargains.

Name _____
Address _____
City _____
State _____ Zip _____

EDMUND SCIENTIFIC CO.

Dept. AV17, Edscorp Bldg.
Barrington, N.J. 08007

Please send me the following items I have indicated below:

Stock No.	Qty.	Price

American Express Charge My Amer. Exp. BAC MC
 BankAmericard Interbank # _____ Acct. # _____
 VISA Card # _____ Exp. Date _____
 Discover Sig. _____

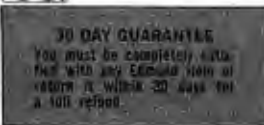

Name _____
Address _____
City _____ State _____ Zip _____

The source of perfection in stereo sound... Pickering's new XSV/3000



The reviewers applaud as never before!

"... we don't see how you can do better at any price."
Hirsch-Houck Laboratories. Stereo Review. February 1977

"The new unit offers the stereo performance of the XUV/
4500Q (or perhaps a little better than that) at a lower
price. It seems hard to go wrong with such a combina-
tion."

CBS Technology Center. High Fidelity. February 1977

"Congratulations to all concerned on a fine contender
amongst the world's best stereo pick-ups."

John Borwick. Gramophone. United Kingdom 1977

Pickering's new XSV/3000 is a remarkable develop-
ment. It possesses a totally new and different design that
makes it the precursor of a whole new generation of so-
phisticated, advanced stereo cartridges.

This has been made possible by technological advances
in two areas. **First**, it has an unusually tiny, samarium
cobalt (rare earth) magnet of remarkably high power that

permits extremely low mass, and also offers high output.
Second, this cartridge features the new Stereohedron™
stylus tip, a Pickering first! This extraordinary shape has a
far larger bearing radius, which provides increased con-
tact area in the record groove. This assures gentler treat-
ment of the record groove, longer record life, and also,
far longer stylus life.

This cartridge provides remarkably smooth and flat fre-
quency response; its channel separation is exceptional,
its transient response possesses superb definition.

Truly, Pickering's XSV/3000 represents a whole new
concept of excellence in stereo cartridges... the true
Source of perfection in stereo sound.

For further information write to
Pickering & Co., Inc. Dept. PE,
101 Sunnyside Blvd., Plainview,
New York 11803



"for those who can hear the difference"

PICKERING & CO., INC., COPYRIGHT 1977

CIRCLE NO. 48 ON FREE INFORMATION CARD



When you've got a Pace CB radio,



you've got the world by the ears.

There are millions out there with their ears on waiting to talk to you Pace to Pace.

And with a Pace CB two-way radio you've got every bit of power the law allows. And features to cut through interference and "bleeders" from other channels.

What's more, it's assembled with computerized circuitry and it's 100% solid state, so it's as trouble-free as a CB can be.

It all adds up to your voice getting out

there clearer and with less distortion, and the other guy's voice coming back just as clear.

To learn more, drop into a Pace place near you. The dealer will tell you just how economical and easy-to-install a Pace is. He'll help you choose the one that's just right for you, too.

Ask him for the world by the ears. He'll know which CB you're talking about.



PACE CB 8015

pace

PACE CB / PACE TWO-WAY RADIO PRODUCTS
BY PATHCOM, INC., HARBOR CITY, CA 90710